



*Serenity*  
marquis  
COLLECTION | by Kingsman



## Installation Instructions

Listed Certified for USA. and Canada

Model Number: MQZDV1917

Stock Numbers: MQZDV1917N, MQZDV1917LP

Certified to: ANSI Z21.88-2002 / CSA2.33-2002  
ANSI Z21.88a-2003 / CSA2.33a-2003  
ANSI Z21.88b-2003 / CSA2.33b-2003, CAN/CGA 2.17-M91

This appliance may be installed in an aftermarket permanently located, manufactured home (USA only) or mobile home, where not prohibited by local codes.

This appliance is only for use with the type of gas indicated on the rating plate. This appliance is not convertible for use with other gases, unless a certified kit is used.

# “Zero Clearance” Direct Vent Gas Fireplace

**Read this complete manual before beginning installation.  
These instructions must be kept with the unit for future reference.**

## FOR YOUR SAFETY

**WARNING: If the information in these instructions are not followed exactly, a fire or explosion may result causing property damage, personal injury or loss of life.**

Warning: Improper installation, adjustment, alteration, service or maintenance can cause property damage, personal injury or loss of life. Refer to this manual. Installation and service must be performed by a qualified installer, service agency or the gas supplier.

Do not store or use gasoline or other flammable vapors and liquids in the vicinity of this or any other appliance.

### What To Do If You Smell Gas

Do not try to light any appliance.  
Extinguish any open flame.  
Do not touch any electrical switch.  
Do not use any phone in your building.  
Immediately call your gas supplier from a neighbour's phone.  
If you can not reach your gas supplier, call the fire department.

## Table of Contents

Pre-installation Questions and Answers .....	3
Why does my fireplace or stove give off odor? .....	3
About Curing of the Paint .....	3
Noise Coming from the Fireplace .....	3
Mobile Home/Manufactured Housing Installation .....	4
Installation and Operation .....	5
Installation Regulations .....	5-6
Installation Requirements for the Commonwealth of Massachusetts .....	7
Fireplace Dimensions .....	8
Dimensional Overview .....	8
Locating the Appliance .....	8
Framing your Gas Fireplace .....	9
Stand-off Locations .....	9
Mounting Tab Selection Guide .....	9-10
General Framing Installations .....	11
Corner Installations .....	12
Raised Installation .....	12
Cabinet Installation Guide .....	12-13
Mantel Clearance Requirements .....	14
Sidewall Clearance Requirements .....	15
Facing Material Installation Guide .....	16
How to Install the Finishing Surround .....	17
Thick Facing Materials .....	17
How to Install the Access Panel Grill .....	18
How to Install the Glass Door .....	19
Removal Guide .....	19
Glass Cleaning .....	19
Cautions and Warnings .....	19
Glass Replacement .....	19
How to Install the Arch Door .....	20
Fan Installation .....	21
Procedures for New Installations .....	21
Fan Testing Procedures .....	21
Fan Kit Removal/Serviceing .....	22
Electrical Considerations .....	22
Baffle Replacement Guide .....	23
Gas Line Installation .....	24
Burner Removal/Serviceing Guide .....	25
Liner Installation Guide .....	26
Millivolt System, Lighting, and Burner Control .....	27
Gas Conversion Instructions .....	28-29
Venting .....	30
Termination .....	30
General Venting Information .....	30
Venting Routes and Components .....	30
Horizontal Vent Table .....	31
General Vent Installation Information .....	32
Simpson Dura-vent, AmeriVent, and Selkirk Direct Temp .....	32
Flex Pipe Venting .....	32
Use High Temperature Sealant .....	33
Installation of Side Wall Venting .....	33
Venting Straight Up Through Roof .....	34
Using Flex Bends .....	34-35
Roof Flashing .....	36
Log C-19 Placement Instructions .....	37-38
Parts List .....	39-40
Troubleshooting the Gas Control System .....	41

## PRE-INSTALLATION QUESTIONS and ANSWERS

### *Why does my fireplace or stove give off odor?*

It is normal for your fireplace to give off some odor. This is due to the curing of the paint, adhesives, silicones and any undetected oil from the manufacturing process as well as the finishing materials used with the installations (e.g. marble, tile and the adhesives used to adhere this product to the walls can react with heat and cause odors).

It is recommended that you burn your gas fireplace or stove for a minimum of four hours at a time with the fan off after the curing of the paint has been completed. These odors can last upward to 40 hours of burn time, keep burning at a minimum of four hours per use until odors dissipate.

### *About curing of the paint*

Your stove or fireplace has been painted with the highest quality silicone stove paint. This paint dries quickly in 15-20 minutes when first applied at the factory. However, due to the high temperature silicone components, the paint will cure when heat is applied to the appliance as it is first used. The following information applies to the curing process to get the paint fully hard and durable.

Fire the appliance four successive times for 10 minutes each firing and a 5 minute cool down between each. Be aware during log and firebox paint curing that a white deposit may be developing on the inside of the glass doors. It is important to remove this white deposit from the glass doors with an appropriate cleaner to prevent build-up (such as Windex or a commercial fireplace glass cleaner).

- Babies, small children, pregnant women and pets should leave the area during the cure phase.
- Ventilate well, open doors and windows.
- Do not touch during curing.

### *Noise coming from the fireplace?*

Noise caused by metal expanding and contracting as it heats up and cools down, similar to the sound produced by a furnace or heating duct. This noise does not affect the operation or longevity of your fireplace.

## Mobile Home/Manufactured Housing Installation

This Direct Vent System Appliance must be installed in accordance with the manufacturer's installation instructions and the Manufactured Home Construction and Safety Standard Title 24 CFR, Part 3280, or the current Standard for Fire Safety Criteria for Manufactured Home Installations, Sites, and Communities ANSI/NFPA 501A, and with CAN/CSA Z240 MH Mobile Home Standard in Canada.

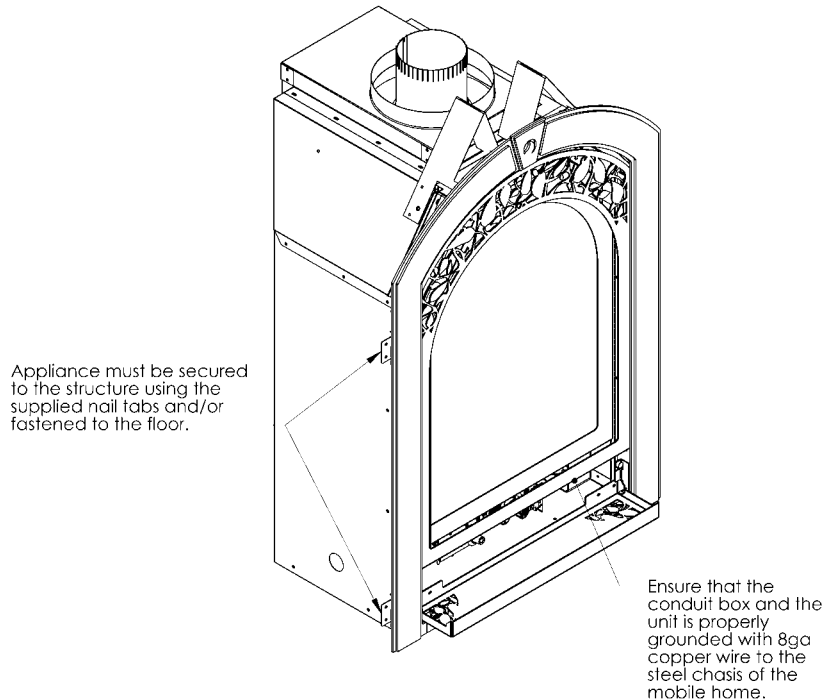

**THE MQZDV1917N AND MQZDV1917LP MAY BE INSTALLED IN MANUFACTURED (MOBILE) HOMES AFTER FIRST SALE IN THE USA. IN CANADA THE MQZDV1917N AND MQZDV1917LP MAY BE INSTALLED IN MANUFACTURED (MOBILE) HOMES.**

Please follow the current ANSI/NFPA 70 National Electrical Code in the USA and CAN/CSA C22.1 Canadian National Electrical Code in Canada.

An appliance must be grounded to the steel chassis of the home with 8ga copper wire using a serrated or star washer to penetrate paint or protective coating to insure grounding.

Use carriage bolt at the attachment point (see diagram above) to secure the appliance to the floor.

**Warning: Do not compromise the structural integrity of the manufactured home wall, floor or ceiling, during installation of appliance or venting.**

For required venting components see venting installation in appropriate section of this manual.

**Certified for installation in a bedroom or bedsitting room. In Canada must be installed with listed millivolt thermostat. In USA see local codes.**

# Installation and Operation

## *Installation Regulations*

This gas appliance must be installed by a qualified installer in accordance with local building codes, or in the absence of local codes, with the current CAN/CGA-B149.1 or .2 Installation Code (in Canada) or the current National Fuel Gas Code Z223.1 when installed in the United States.

This appliance, when installed, must be electrically connected and grounded in accordance with local codes, or in the absence of local codes, with the current CSA C22.1 Canadian Electrical Code or with the national Electrical Code; ANSI/NFPA 70-1987 when installed in the United States.

### **Vertical Venting in Cold Climates**

In cold climate conditions where temperatures go below -10 degrees Celsius or 14 degrees Fahrenheit, we recommend that the chase be insulated and where the vent pipe enters into the attic space that the pipe be wrapped with an insulated Mylar sleeve. This will increase the temperature of the vent and help the appliance to vent properly in cold weather conditions.

It is also important in vertical vented direct vent appliances that the appliance be operated daily during the winter months as this will help stop the termination from freezing up. We recommend using a thermostat set at room temperature to allow the unit to cycle.

### **For Safe Installation and Operation of Your Gas Fireplace Please Note The Following:**

1. This appliance gives off high temperatures and should be located out of heavy traffic areas and away from furniture and draperies.
2. Children and adults should be alerted to the hazards of the high surface temperatures of this appliance and should stay away to avoid burns or ignition of clothing.
3. Children should be carefully supervised when they are in the same room as your fireplace appliance.

**NOTE:** It is recommended that a Carbon Monoxide (CO) detector be installed in or near bedrooms and on all levels of your home. Place a detector about 15ft [4.5m] outside the room that houses your gas appliance.

**Warning: When purging the gas line, the glass front must be removed.**

4. Never use your gas fireplace as a cooking device.
5. The Burner/Log Assembly has been engineered and permanently adjusted for proper flame control.

**Do not alter gas orifice.**

6. Under no circumstances should this appliance be modified. Any parts that have to be removed for servicing should be replaced prior to operating this appliance.
7. Installation and repair should be done by a qualified service person. The appliance should be inspected before use and at least annually by a professional service person. More frequent cleaning may be required due to excessive lint from carpeting, bedding material, etc. It is imperative that control compartments, burners and circulating air passageways of the appliance be kept clean.
8. Control compartments, burners and air passages in this appliance should be kept clean and free of dust and lint. Make sure that the gas valve and pilot light are turned off before you attempt to clean this unit.
9. The venting system (chimney) of this appliance should be inspected at least once a year and if needed, your venting system should be cleaned.
10. Clothing or other flammable material should not be placed on or near the appliance. This appliance should not be used as a drying rack for clothing nor should Christmas stockings or decorations be hung from it.

11. Under no circumstances should any solid fuels (wood, paper) be used in this appliance.
12. For safe operation, glass doors must be closed.
13. Do not use this heater if any part has been under water. Immediately call a qualified service technician to inspect the heater and to replace any part of the control system and any gas control which has been under water.
14. **WARNING:** Do not operate appliance with the glass front removed, cracked or broken. Replacement of glass should be done by a licensed or qualified service person.
15. Do not operate appliance unless completely installed as per installation instructions.
16. In the Commonwealth of Massachusetts a CO detector must be installed in the same room as the appliance.
17. This gas appliance may be used only for supplemental heat and/or decorative purposes and under no circumstances shall they provide a primary heat source.

Periodically remove the logs from the grate assembly and vacuum any loose particles from the grate and burner areas.

See Log C-19 Placement Instructions on page to remove logs, vacuum burner parts and replace logs.

**NOTE:** It is normal for your gas fireplace to give off some odor the first time it is burned. This is due to the curing of the paint and any undetected oil from the manufacturing process.

Please ensure that your room is well ventilated - open all windows. It is recommended that you burn your gas fireplace for at least four [4] hours the first time you use it without the fan on.

Make adequate accessibility clearances for servicing and proper operation.

This appliance must not be connected to a chimney flue serving a separate solid fuel burning appliance.

Be sure that the flow of combustion and ventilation air is not obstructed.

## Installation Requirements for the Commonwealth of Massachusetts

In the Commonwealth of Massachusetts, the installer or service agent shall be a plumber or gas fitter licensed by the Commonwealth.

When installed in the Commonwealth of Massachusetts or where applicable codes; the unit shall be installed with a CO detector per the requirements listed below.

1. For direct-vent appliances, mechanical-vent heating appliances or domestic hot water equipment, where the bottom of the vent terminal and the air intake is installed below four feet above grade the following requirements must be satisfied:
  - A. If there is not one already present, on each floor level where there are bedroom(s), a carbon monoxide detector and alarm shall be placed in the living area outside the bedroom(s). The carbon monoxide detector shall comply with NFPA 720 (2005 Edition).
  - B. A carbon monoxide detector shall be located in the room that houses the appliance or equipment and shall:
    - a. Be powered by the same electrical circuit as the appliance or equipment such that only one service switch services both the appliance and the carbon monoxide detector;
    - b. Have battery back-up power;
    - c. Meet ANSI./UL 2034 Standards and comply with NFPA 720 (2005 Edition); and
    - d. Have been approved and listed by a Nationally Recognized Testing Laboratory as recognized under 527 CMR.
  - C. A Product-approved vent terminal must be used, and if applicable, a Product-approved air intake must be used. Installation shall be in strict compliance with the manufacturer's instructions. A copy of the installation instructions shall remain with the appliance or equipment at the completion of the installation.
  - D. A metal or plastic identification plate shall be mounted at the exterior of the building, four feet directly above the location of vent terminal. The plate shall be of sufficient size to be easily read from a distance of eight feet away, and read "Gas Vent Directly Below".
2. For direct-vent appliances, mechanical-vent heating appliances or domestic hot water equipment where the bottom of the vent terminal and the air intake is installed above four feet above grade the following requirements must be satisfied:
  - A. If there is not one already present, on each floor level where there are bedroom(s), a carbon monoxide detector and alarm shall be placed in the living area outside the bedroom(s). The carbon monoxide detector shall comply with NFPA 720 (2005 Edition).
  - B. A carbon monoxide detector shall:
    - a. Be located in the room that houses the appliance or equipment;
    - b. Be either hard-wired or battery powered or both; and
    - c. Shall comply with NFPA 720 (2005 Edition).
  - C. A Product-approved vent terminal must be used, and if applicable, a Product-approved air intake must be used. Installation shall be in strict compliance with the manufacturer instructions. A copy of the installation instructions shall remain with the appliance or equipment at the completion of the installation.

# Fireplace Dimensions

## Dimensional Overview

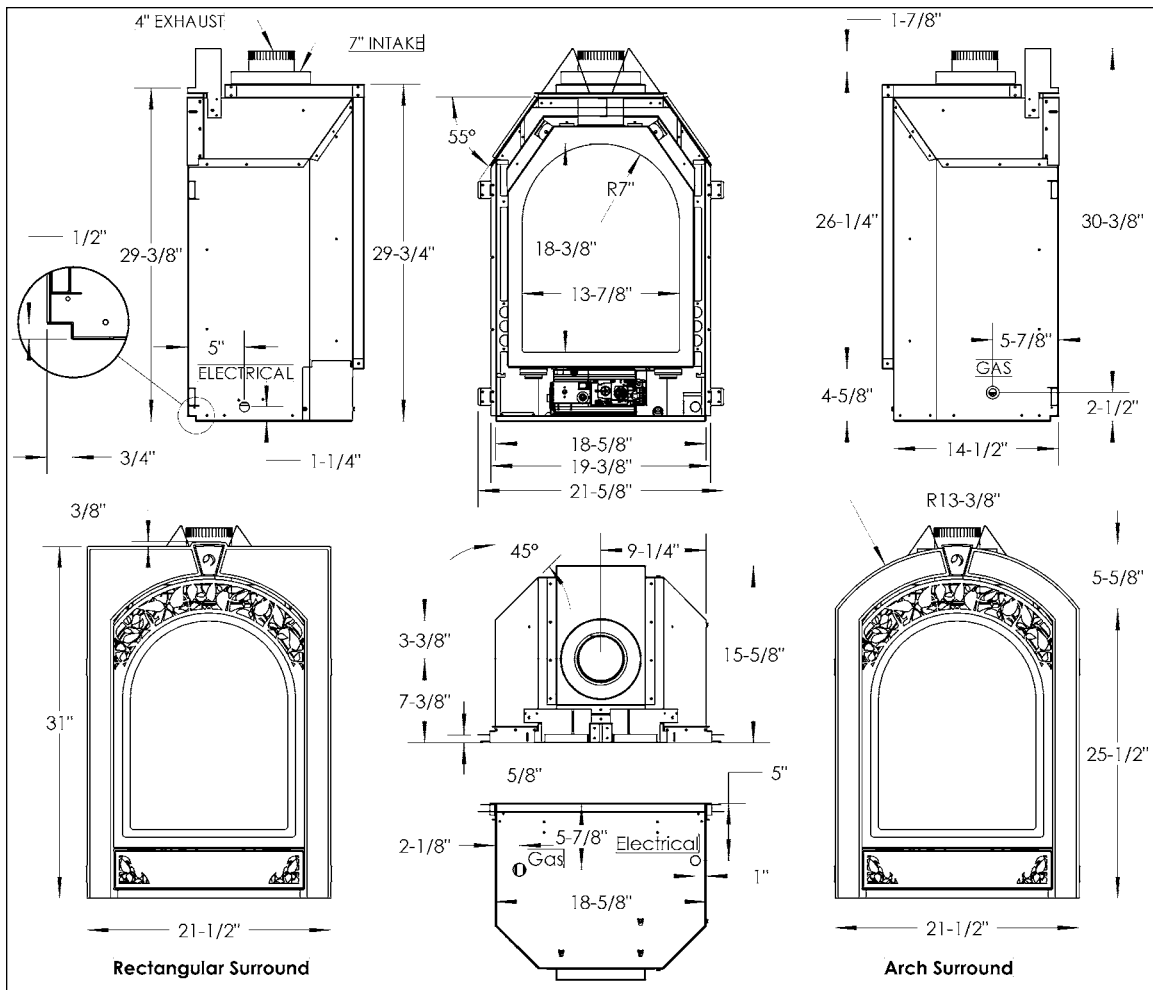

Figure 1 - An overview of the dimensions involved.

## Locating the Appliance

The appliance can be located in the configurations shown in Figure 2. Note that an Island installation with a top vent is possible as long as the horizontal portion of the vent system does not exceed 20ft [6.1m].

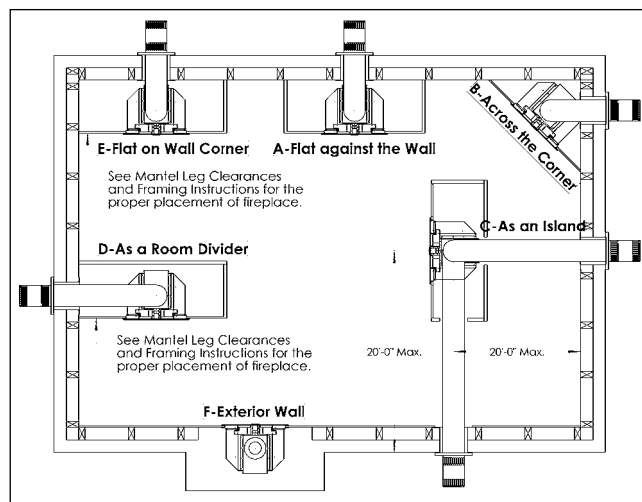

Figure 2 - Possible fireplace location suggestions.

## Framing for your Gas Fireplace

This section will cover four different types of installations: General, Corner, Raised, and Cabinet installation. It is intended for qualified installers only.

Before beginning, make note of where the gas and electrical accesses are located on the unit. This will streamline the construction process. Furthermore, familiarize yourself with the venting and clearance requirements (see Venting section) for this appliance. Failure to comply with those requirements can seriously compromise the safety and operation of the fireplace.

### Specifications

1. Cold climate installation recommendation: When installing this fireplace against non insulated exterior wall or chase, it is recommended that the outer walls be insulated to conform to applicable insulation codes. Drywall must be installed over insulation to prevent contact of insulation and unit.
2. Choose fireplace location and frame in accordance with the fireplace framing dimensions specified (see framing diagrams).
3. Drywall or other material can extend up to the various Stand-offs located on the side and top surfaces of the unit, and flush with the bottom (see Stand-off Locations section). Please note that 1/2" facing material (e.g. drywall) can be extended into the lower cavity of the unit.
4. When installing horizontal with a 90 degree bend maintain a minimum of two and a half inches [2.5"] above the bend in enclosures.
5. A Hearth is not required for this unit.

It is recommended for **Propane Horizontal Installations** that the venting should be a minimum of one foot vertical off the flue before the elbow on any horizontal runs of one foot or greater. This allows for cleaner combustion, and greatly reduces carbon deposits and cleaning of glass. (Does not apply to Back Flue models)

### Stand-off Locations

Please make note of where the stand-off locations are. These stand-offs are provided as indicators to illustrate the boundaries for framing. Therefore, no construction material is permitted to extend beyond these stand-offs.

The Facing Material Lower Cavity is a channel designed to permit facing material (maximum of 1/2" thick) to extend into. The maximum extension allowed is 7/16" [1.1cm].

### Mounting Tab Selection Guide

The Mounting Tabs are designed for installation of two different configurations. The first, as shown in Figure 3, is the Stud Mount configuration, and the second is the Cabinet Mount configuration.

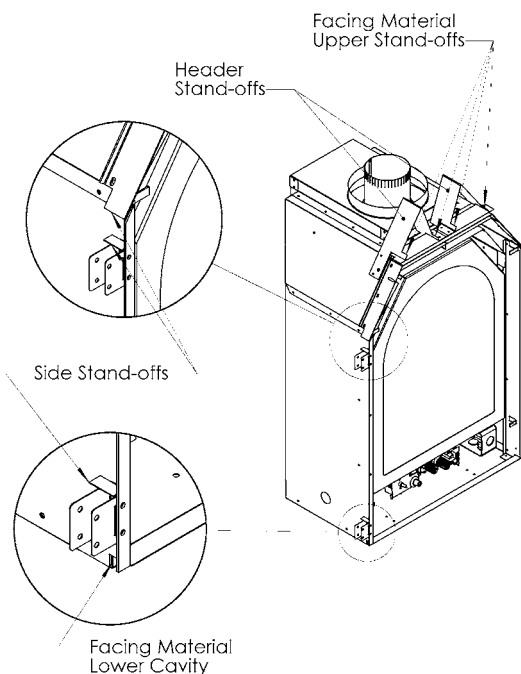

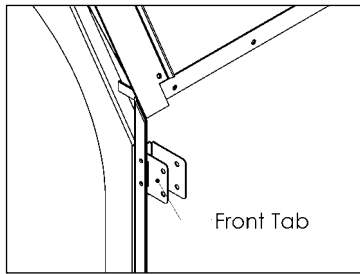

Figure 3 - Stud mount configuration

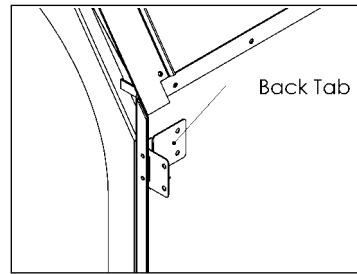

Figure 4 - Cabinet mount configuration.

The Stud Mount configuration is for instances where facing material will be used. This includes dry-wall, granite, slate, marble, brick, and various other combustible and non-combustible materials. To mount the unit to a stud, simply bend the Back Tabs forward in the position shown in Figure 3. The Front Tabs may be bent forward to clear a way for access to the screw holes. Using the holes provided on the Back Tab, fasten the unit to the studs with the appropriate eight [8] screws.

**NOTE:** The Front Tab can be cut and discarded in the Stud Mount configuration.

For Cabinet installations, bend the Back Tabs back flush against the side of the unit. Using the holes on the Front Tabs, fasten the appliance to the Cabinet with the appropriate eight [8] screws.

**NOTE:** Before fastening the mounting screws, ensure that the unit is level.

<b>Clearance to Combustibles</b>	
Back	0" [0cm]
Side (from standoffs)	0" [0cm]
Floor	0" [0cm]
Minimum Ceiling Height (from bottom of fireplace)	44" [112cm]
Top (from standoffs)	0" [0cm]
Top of 90° Bend	3" [7.6cm] All Vent Systems
Top of 90° Bend over 44" [112cm] Enclosure	2 1/2" [6.4cm] All Vent Systems
Top of Horizontal Pipe	1 1/2" [3.8cm] All Vent Systems
Side & Bottom of Horizontal Pipe	1" [2.5cm] All Vent Systems
Vertical Vent Pipe	1" [2.5cm] All Vent Systems
Vertical Vent Pipe	1 1/4" [3.2cm] Simpson/AmeriVent/Selkirk Direct Temp Systems

Table 1 - Clearance to combustibles for fireplace appliance.

## General Framing Installations

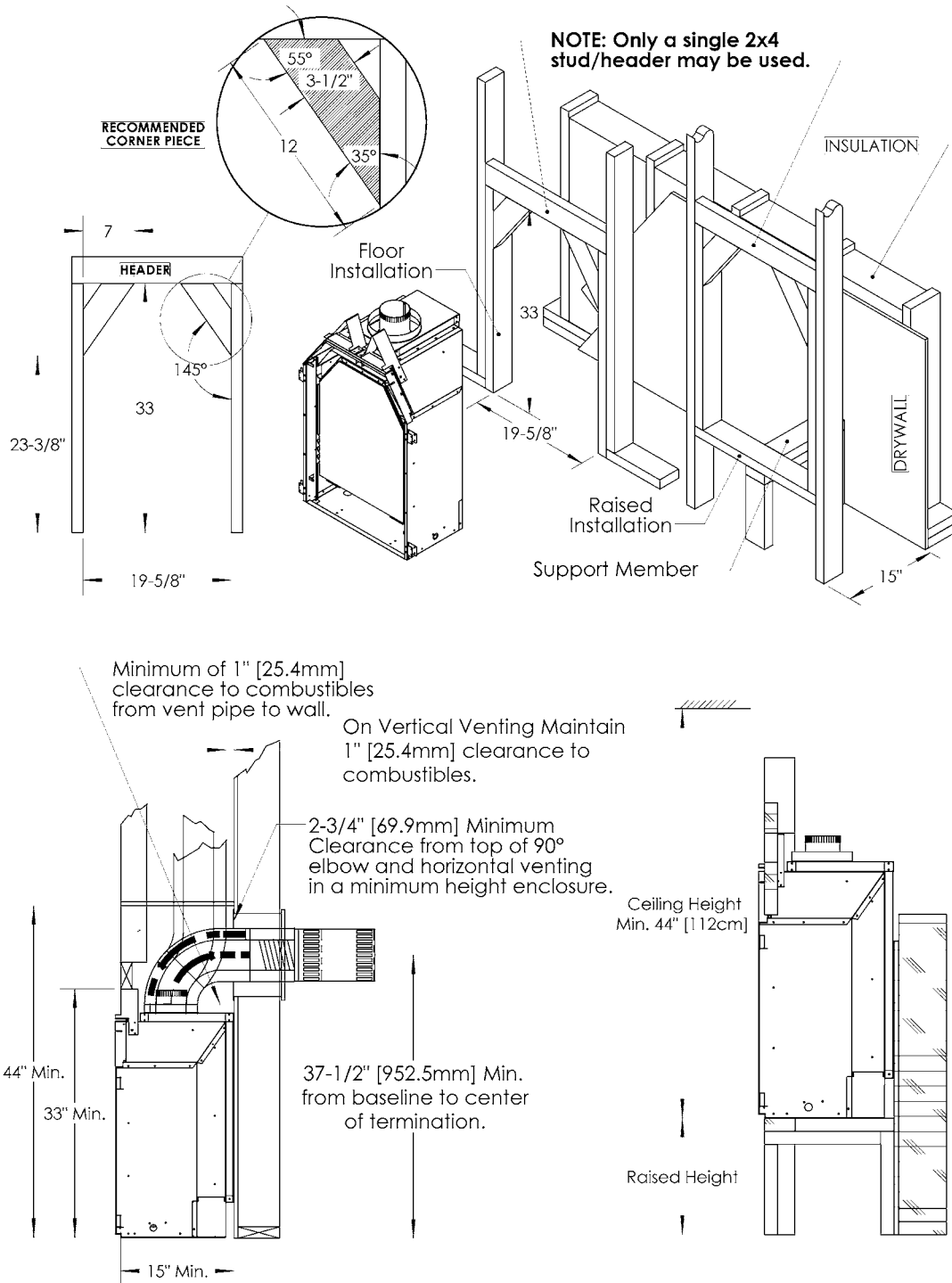
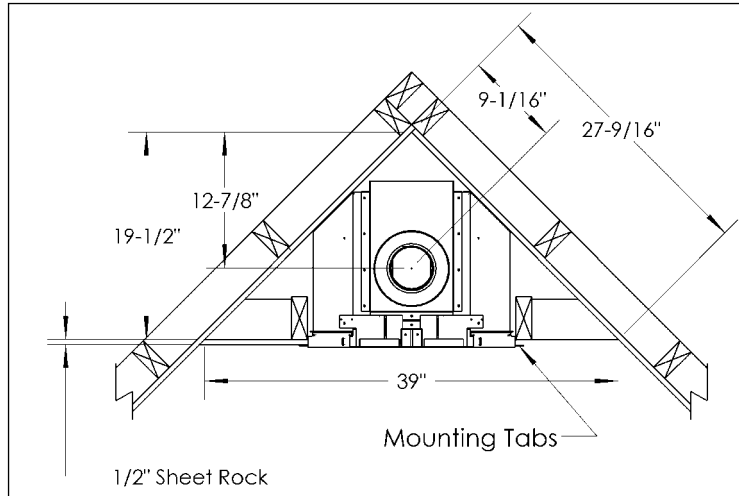

Figure 5 - General framing installation.

## Corner Installations

For Corner Installations the minimum clearance to combustibles in Table 1 must still be adhered to. Please refer to Figure 5 and the Clearance to Combustibles table for more information.

In Figure 6, the minimum dimensions of a corner framing scenario is illustrated.



## Raised Installation

For Raised Installations the minimum clearance to combustibles mentioned in Table 1 must still be adhered to. Please refer to Figure 5 and the Clearance to Combustibles table for more information. Furthermore, make special considerations to the Minimum Ceiling height restriction. This value is taken from the bottom of the appliance—**not the floor**. Thus, if the unit is installed in a raised configuration then the absolute ceiling height will be:

$$\text{Absolute Minimum Ceiling Height} = \text{Min. Ceiling Height} + \text{Raised Height}$$

This formula is illustrated in Figure 5.

## Cabinet Installation Guide

For cabinet installations: It is necessary that the appliance be installed from the rear of the cabinet. Simply bend the front Nailing Tabs enough so they clear the cabinet cutout. Once the appliance is positioned through, restore the front Nailing Tabs to their mounting configuration. Once installed, they should be in front of the face of the cabinet.

Furthermore, it is imperative that the appliance is resting on a secure platform. Consult with the cabinet manufacturer to ensure that the supporting platform is capable of carrying the load of the appliance.

NOTE: Additional access to the gas valve and electrical conjunction box is provided. These cutouts are located at the bottom of the unit. Please refer Figure 1 for the dimensional location.

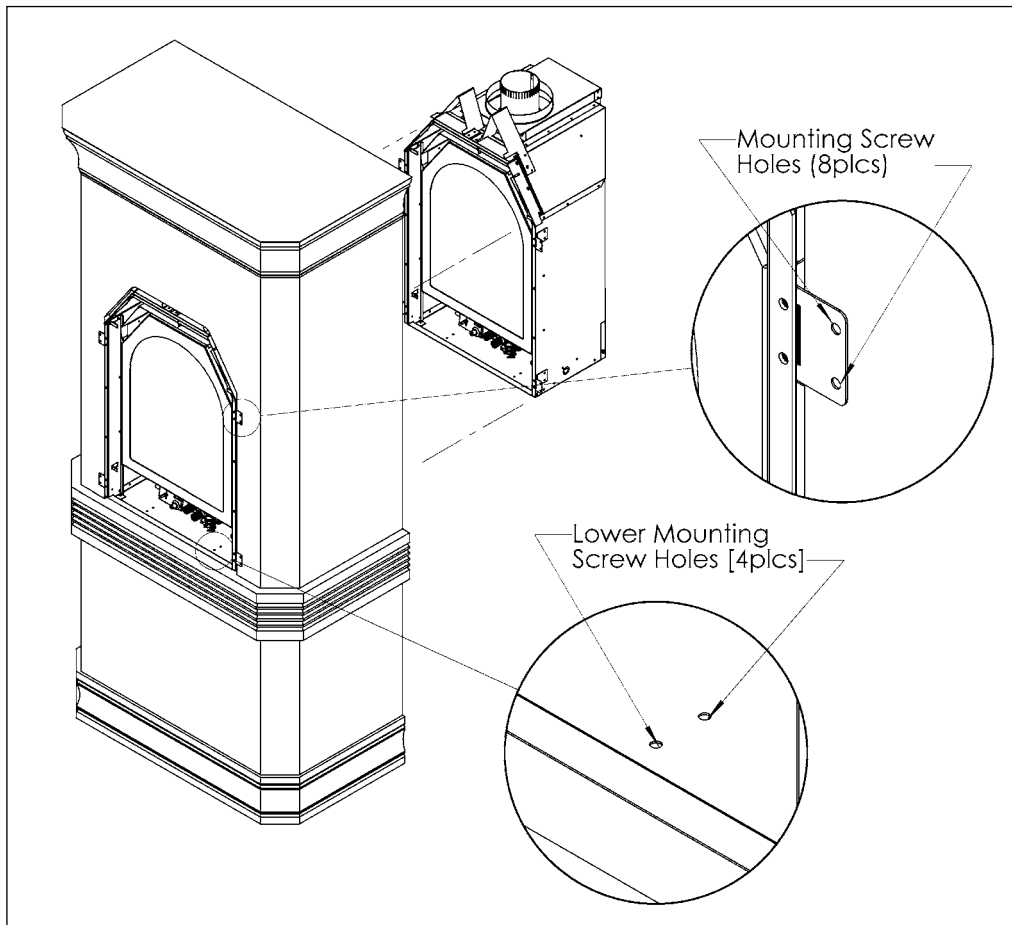

Figure 7 - Cabinet installation. Note that the unit MUST be installed from the back of the cabinet.

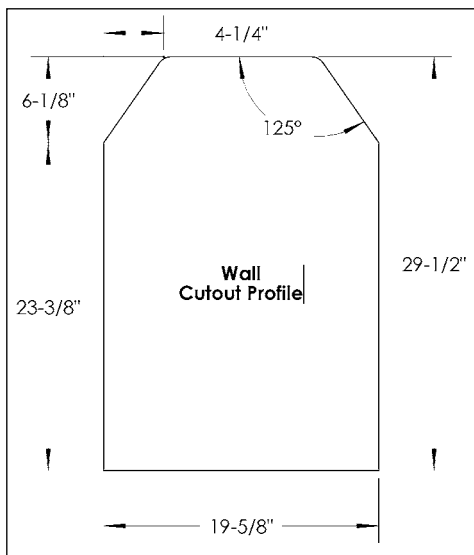
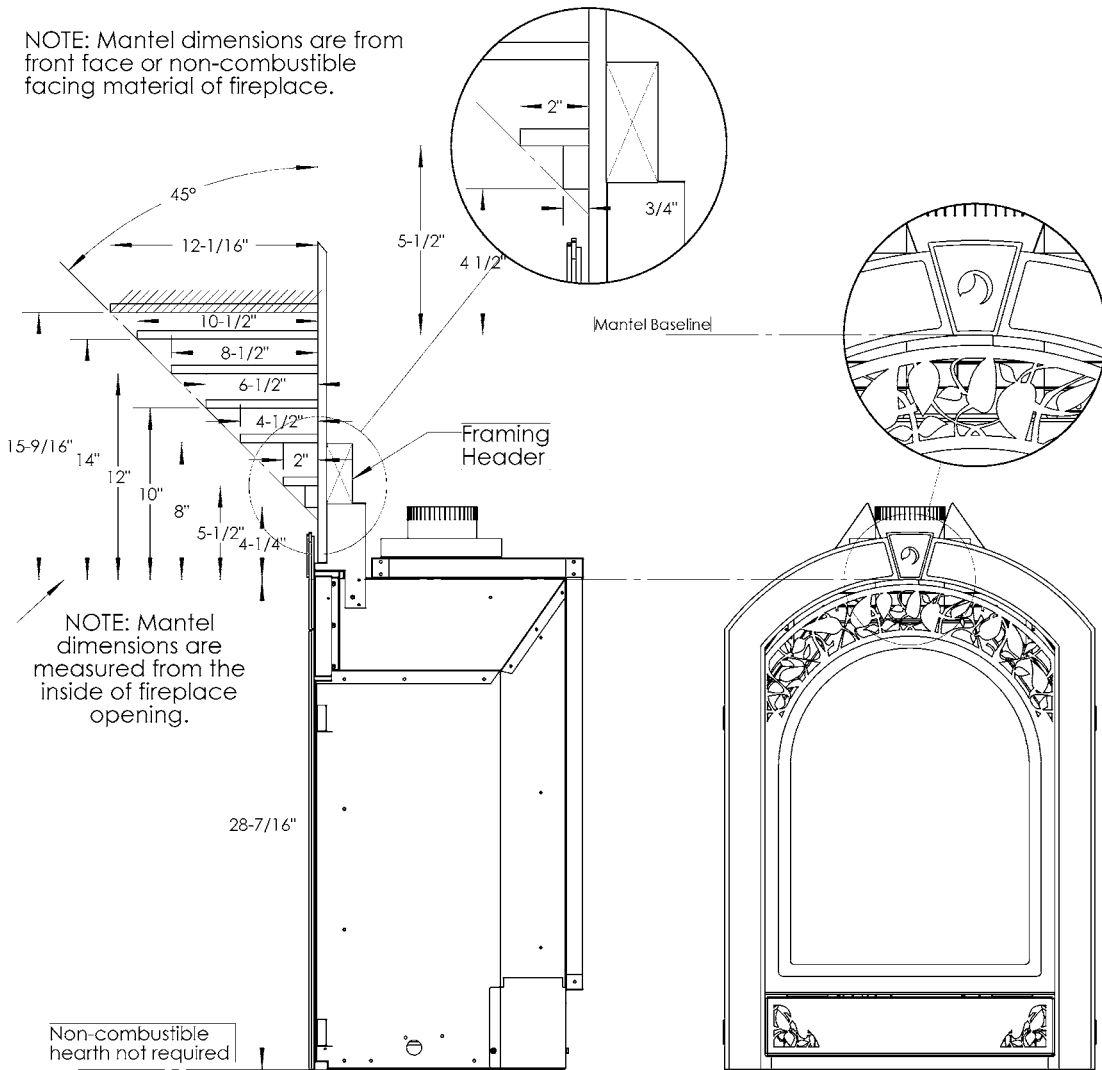

Figure 8 - Dimensions for facing material cutout.

## Mantel Clearance Requirements

Combustible materials may be installed right up to the stand-offs on the unit (see page 4 for Stand-off Locations). For mantles with combustible material please refer to Figure 9 on page 4 for clearance information.

**NOTE:** Non-combustible mantels can be installed at any height above the fireplace vent opening. When using paint or lacquer to finish the mantel, such paint or lacquer must be heat resistant (250°F [121°C]) to prevent discoloration.



**WARNING:** Combustible objects must not be placed on a non-combustible mantel unless the non-combustible mantel meets the minimum height and width requirements for a combustible mantel.

Figure 9 - Mantel clearance information.

### Example

If a mantel is desired to extend 4-1/2" beyond the non-combustible facing material; the point at which it is 4-1/2" outward, it must also be 8" upward above the upper arch of the vent opening.

## *Sidewall Clearance Requirements*

Any installation with a sidewall (i.e. a wall perpendicular to the face of the unit) must adhere to the clearances imposed by the illustration shown in Figure 10.

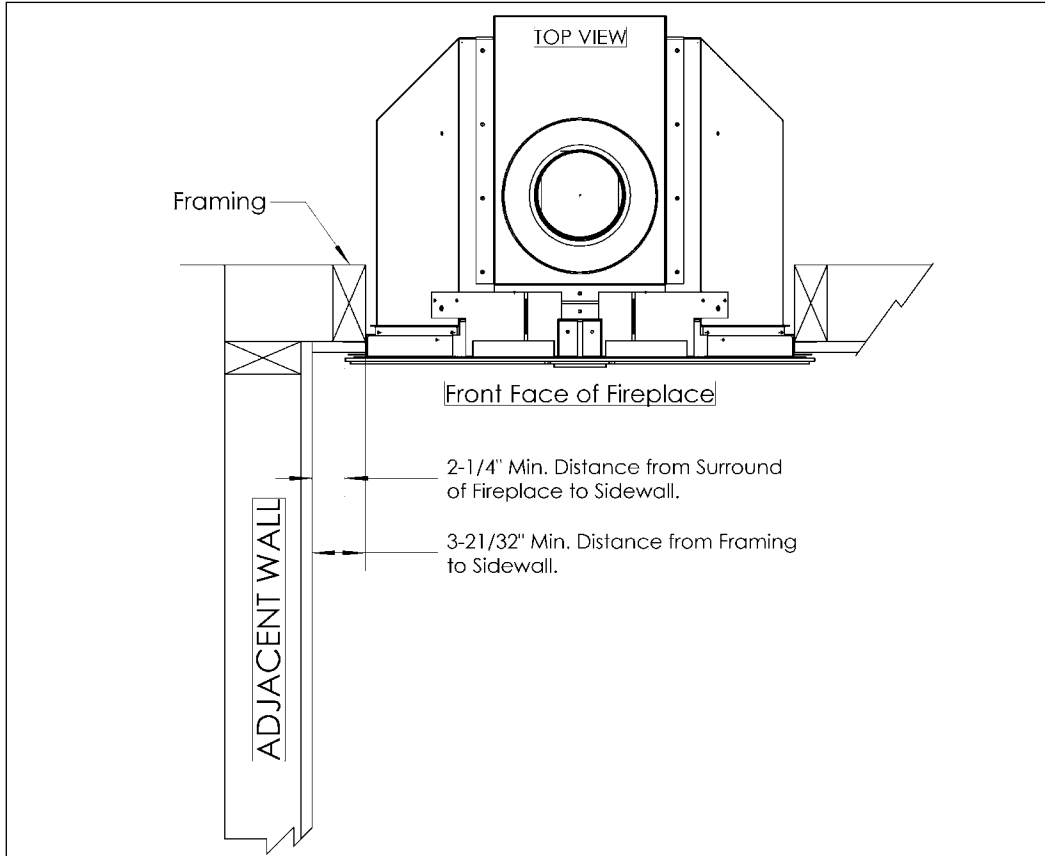

Figure 10 - Sidewall clearance requirements.

## Facing Material Installation Guide

The entire Facing Material for this unit may either be of combustible or non-combustible material. It is recommended that the Facing be installed after the unit is secured in its framing and properly vented. A cutout profile for this unit is shown in the Dimensional Overview section (see page 4).

**NOTE: Only one 2x4 stud/header may be used in the frame. Please refer to Figure 5 on page 4 or Figure 11 below.**

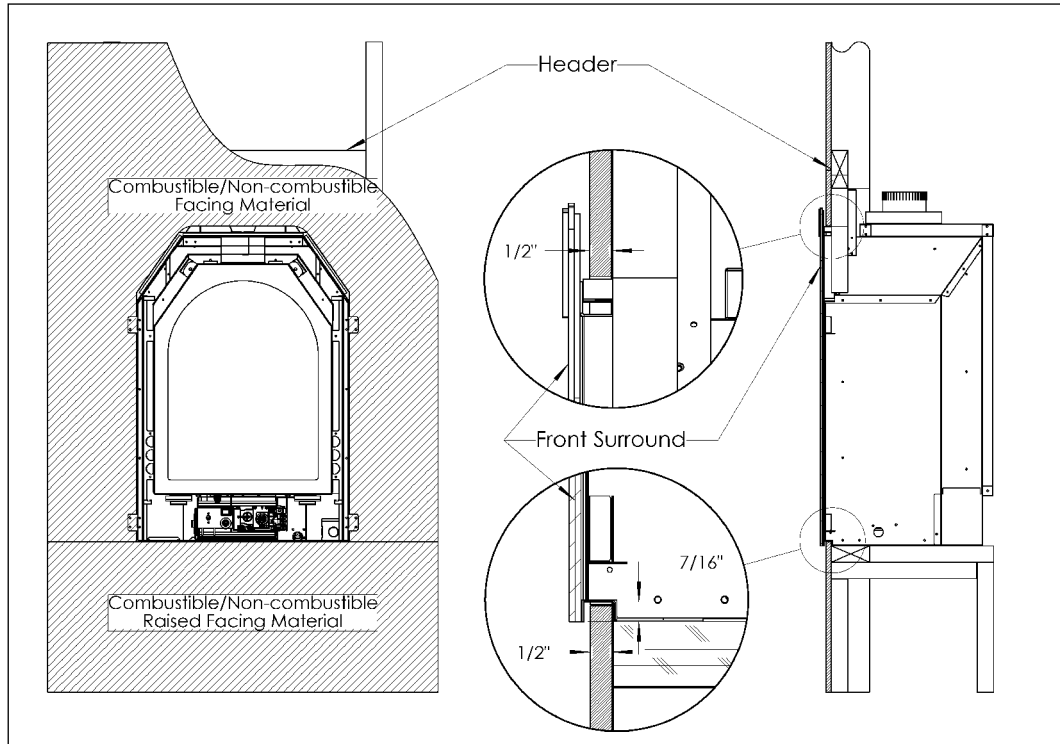

Figure 11 - Installation guide for 1/2" facing material.

To ensure the Front Surround covers the maximum area of the cutout, it is recommended that the upper corners of the cutout be rounded with a 1" to 2" [25.4mm to 50.8mm] radius. This is shown in Figure 12.

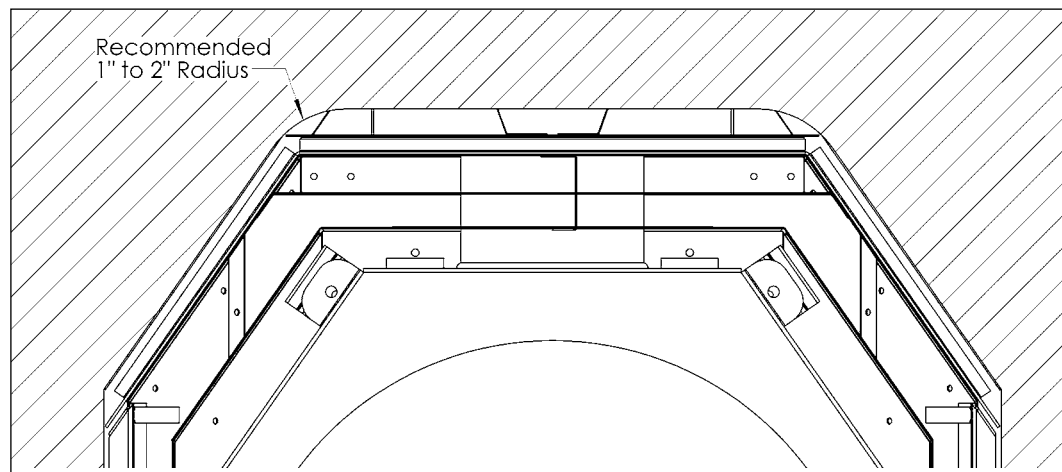

Figure 12 - Recommended 1" to 2" radius on upper corner of facing material cutout.

## How to Install the Finishing Surround

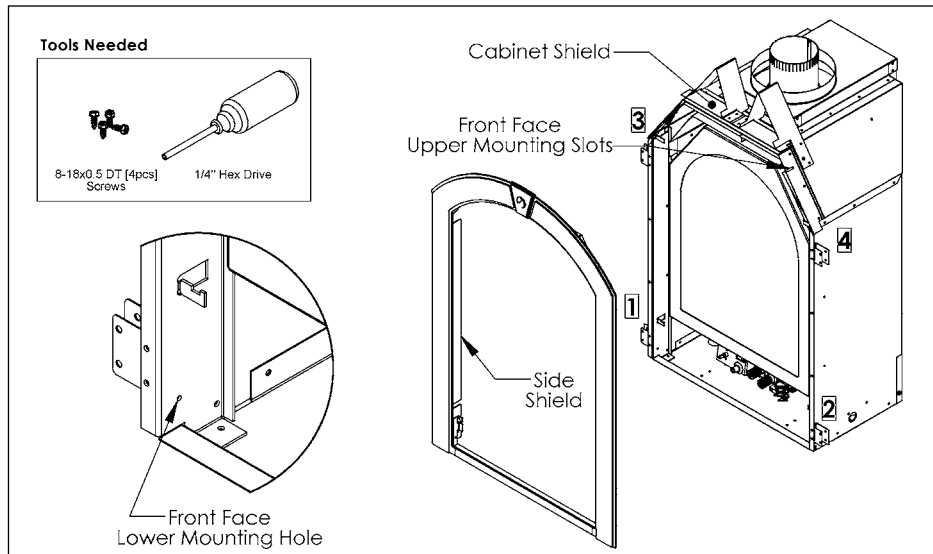

Figure 13 - Finishing Surround installation guide.

1. Make note of where the mount locations are. There should be four [4] places as shown in the illustration on the right.
2. Slide the Surround onto the unit. Rest the upper ledge of the Surround on top of the unit but below the Cabinet Shield. The Side Shields of the Surround should slide along the INSIDE face of the unit.
3. Using the screws provided, loosely fasten the Surround onto the unit at the four [4] mounting locations. Adjust the depth of the Surround appropriately, and then tighten the finished.

NOTE: This Surround is capable of extending 5/8" away from the front of the unit. Hence, a wider range of facing materials can be accommodated without relocating the unit.

4. To remove the Front Face Surround simply reverse these steps.

### ***Thick Facing Materials***

This unit is designed to extend its Front Surround 5/8" [15.9mm] outwards to accommodate a larger range of Facing Material without the need for reframing. Therefore, the maximum thickness for Facing Material is 1-1/8" [28.6mm].

To extend the Front Surround forward:

1. Loosen the four [4] mounting screws for the Front Surround,
2. Pull the Surround forward to the desired distance,
3. And then secure the Surround by tighten the four [4] mounting screws.

The location of the mounting screws is shown in Figure 13.

## How to Install the Access Panel Grill

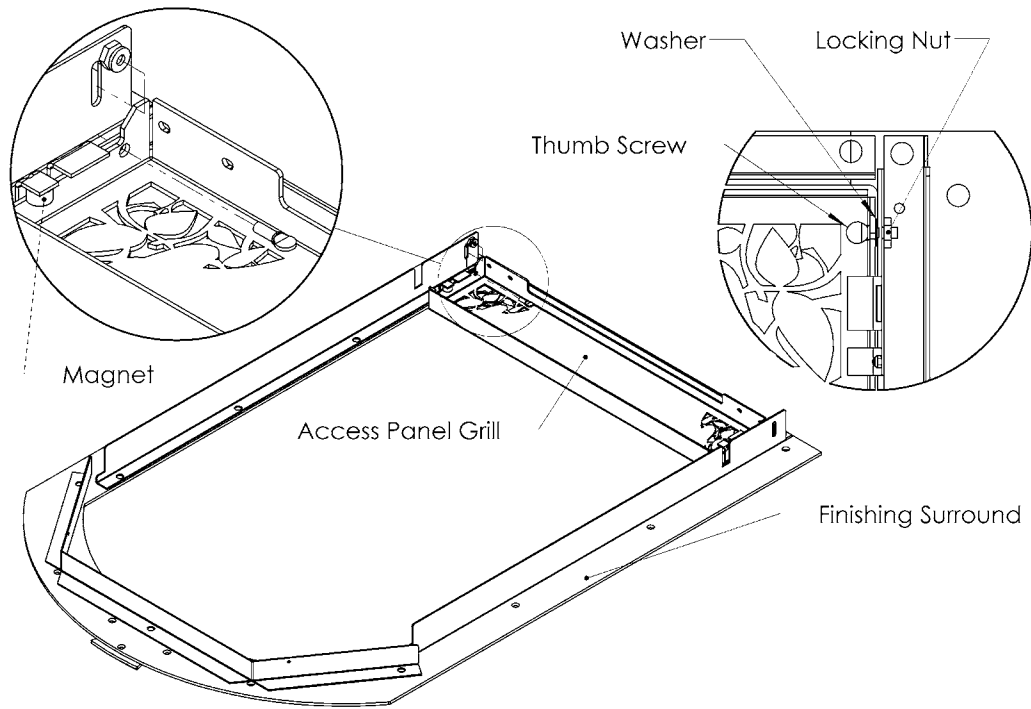

Figure 14 - Lower Access Panel installation and removal guide.

1. Lay the Finishing Surround on its face and position the Access Panel Grill in the fashion shown in Figure 14. Ensure that a soft cloth is placed underneath the Finishing Surround and the Access Panel Grill to avoid scratching.

**NOTE:** By bending the Magnet Tabs back or forth, the alignment of the Lower Access Panel can be adjusted. However, excessive bending may result in the Magnet Tabs breaking.

2. Ensure that the magnets (2pcs) are placed on the appropriate tabs as shown in Figure 14.
3. Using the thumb screws, washers, and locking nuts provided fasten the Access Panel Grill to the Finishing Surround frame. Observe the locations of the screw, washer, and nut. Torque the nut appropriately to the desired tightness.
4. To remove the Access Panel Grill simply reverse these steps.

## How to Install the Glass Door

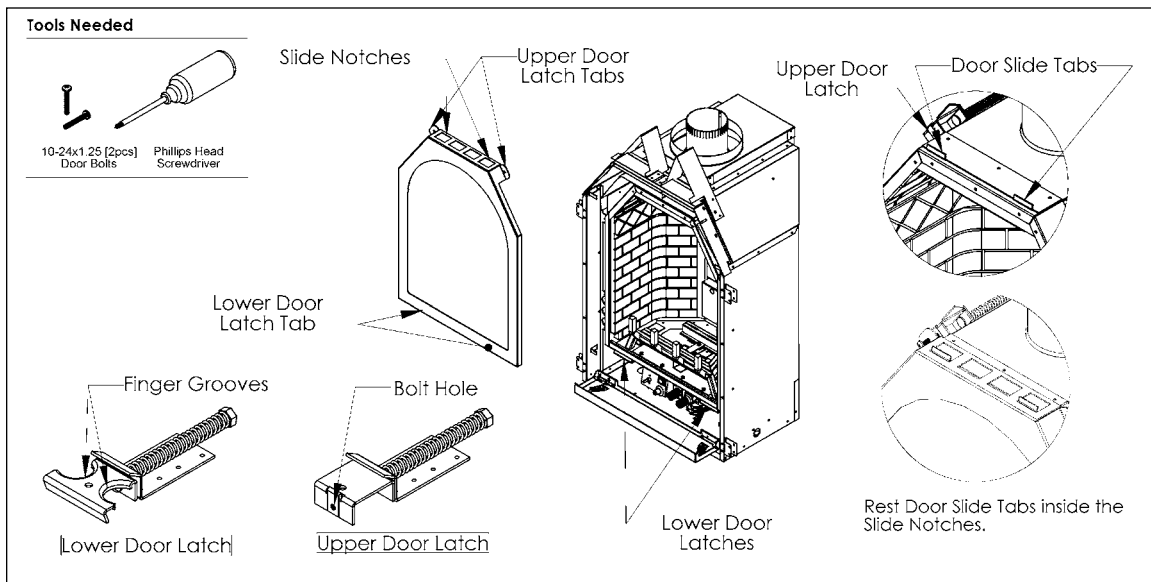

Figure 15 - Glass door installation guide.

### Removal Guide

Remove the Middle Frame (Please refer to page 4). Release the two [2] Lower Door Latches by pulling them out and over the Door Tabs. Unscrew the Upper Door Latches from the Glass Door. Slide the Door out and over the Slide Tabs. To install the Glass Door, simply reverse these steps.

### Glass Cleaning

It will be necessary to clean the glass periodically. During start-up, condensation (which is normal) forms on the inside of the glass and causes dust, lint, etc. to cling to the glass surface. Also, initial paint curing can deposit a slight film on the glass. It is therefore recommended that initially the glass be cleaned two or three times with non-abrasive common household glass cleansers and warm water. After that, the glass should be cleaned two or three times a season depending on the circumstances.

### Cautions and Warnings

1. Do not clean when the glass is hot.
2. The use of substitute glass will void all product warranties.
3. Care must be taken to avoid breakage of the glass.
4. Do not operate this fireplace without the glass front or with a broken glass front.
5. Do not strike or abuse glass.

### Glass Replacement

To replace glass, clean all materials from the door frame. Scrape off old silicone all the way down to the metal. Using high-temp silicone [rated up to 500°F (260°C)] apply a continuous bead of approximately 1/32" to all four [4] sides of the frame. With the frame resting on a flat surface, insert the new glass with a new gasket. Gently press the glass into the silicone. Be careful not to use excessive force on the glass. Let the silicone dry for approximately 15-20minutes.

NOTE: Model Series MQZDV1917 must use Robax ceramic, or coated Neoceram, glass that is a minimum of 5mm thick but cannot exceed 6mm.

## How to Install the Arch Door

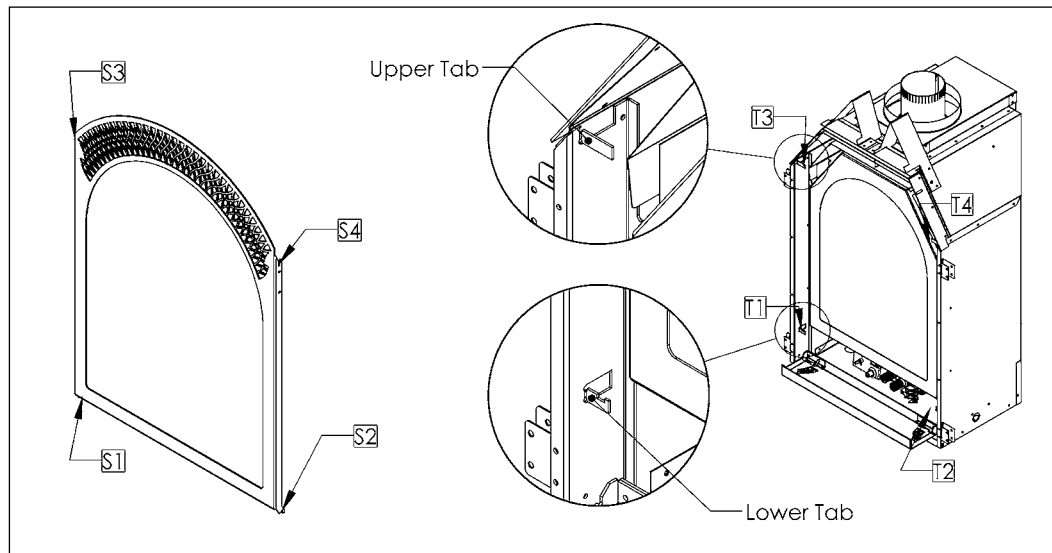

Figure 16 - Arch Door mounting tab locations.

1. Ensure that the Lower Access Panel is in the OPEN position. Make note of the four [4] Mounting Tabs located on the unit [T1-T4], and the four [4] Mounting Slots on the Arch Door [S1-S4] (see Figure 16).
2. Slide the Arch Door into the unit as shown in Figure 17. Ensure that the upper portion of the frame is INFRONT of the Upper Mounting Tab, and the lower portion is BEHIND the Lower Mounting Tab.

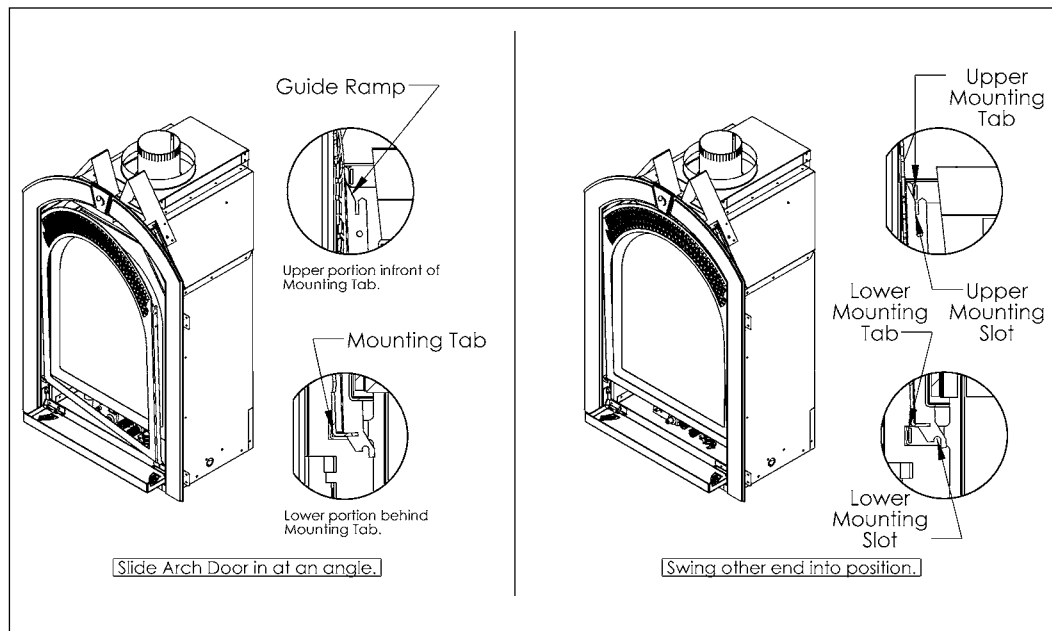

Figure 16 - Arch Door mounting tab locations.

3. Swing the right side of the Arch Door into the unit. Position the Upper Mounting Tab so that it is sitting at the base of the Guide Ramp.
4. Slide the Frame upward, along the Guide Ramp, and rest the Lower Mounting Slots [S1 and S2] onto the Lower Mounting Tabs [T1 and T2]. NOTE: Check to ensure that the Upper Tabs T3 and T4 are inside the Slots S3 and S4.
5. To remove the Arch Door please reverse these steps

## Fan Installation

For new installations, it is recommended that the Fan Kit be installed prior to framing the fireplace. This can be accomplished by utilizing the Fan Access Cover shown in Figure 18.

**CAUTION: DO NOT ATTACH 120V FAN ASSEMBLY TO MILLIVOLT GAS VALVE SYSTEM.**

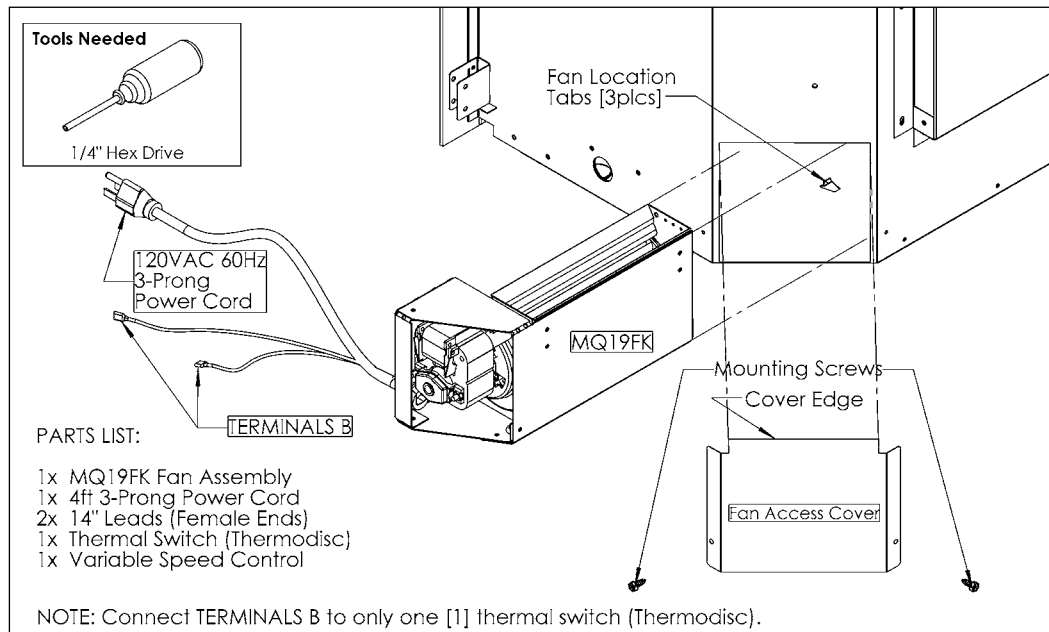

Figure 18 - Optional Fan Kit installation.

### *Procedures for New Installations*

1. Remove the Fan Access Cover mounting screws. *Make note of how the Cover Edge is positioned on the inside of the unit rather than the outside.*
2. Slide the MQFK19 fan assembly into the fireplace cavity. Position the three [3] rubber pads on the fan kit on the three [3] Fan Location Tabs inside the fireplace unit. Set the fan assembly down securely on those location tabs.
3. For the TERMINALS B connection, there are two [2] options: 1) to have the thermal switch controlling the fan directly, simply connect the TERMINAL B wires to the thermal switch (Thermodisc) terminals. 2) To have a unit-mount variable control controlling the fan speed in conjunction with thermal switching, simply connect the TERMINALS B wires to both the Thermodisc and variable control switch in series (see Figure 19).
4. Install a power receptacle in the junction box provided. Connect the fan's power cord to that receptacle.
5. Replace the Fan Access Cover ensuring that the Cover Edge is positioned inside the cavity of the fireplace.

### *Fan Testing Procedures*

1. Turn the fireplace ON. The thermal switch should engage when its designed threshold temperature is reached. This should take approximately 10 to 15 minutes. The fan will automatically shut off when the temperature of the fireplace cools down.
2. If a variable control is installed, turn the knob clockwise to switch on the fan. Turn the knob fully counter-clockwise will switch the fan off.

3. If the fan is working properly, you do not need to continue with these test procedures.
4. If the fan does not respond, check the wiring to ensure proper connections. See the Electrical Considerations section on page 4 for reference. Make note that the dark thick connection lines are BUS LINES that represents multiple lines and not one solitary connection.
5. Using a volt-meter, check the receptacle to verify that there is 120VAC 60Hz power available. If there is power at the receptacle, unplug the power cord to the fan kit and check the integrity of the wires to ensure that there are no damages.
6. Unplug the leads from the thermal switch and check for continuity. If the thermal switch is OPEN, wait a little longer in case the proper temperature is not yet reached. If the thermal switch remains OPEN, then replace the thermal switch.
7. If the thermal switch is CLOSED then unplug the leads from the variable speed control and, using an ohm-meter, check for varying resistance. If the meter does not indicate varying resistance, or shows a constant OPEN circuit, then replace the variable speed control.

### ***Fan Kit Removal/Serviceing***

This unit is designed so that the fan kit may be removed without the complete dismantling of the appliance from its framing.

NOTE: Before beginning, be familiar with electrical safety and ensure that all electrical and fuel supply are disconnected and shut off.

Label all wires prior to disconnection when servicing the controls. Wiring errors can cause improper and dangerous operation.

Verify proper operation after servicing.

1. Disconnect the fan kit power cord from the receptacle, and the two [2] leads from the variable speed control/thermal switch. Remove the Burner Pan assembly. (Refer to the Burner Removal/Serviceing Guide section on page 4.)
2. Lift the fan assembly up and over the three [3] mounting tabs and slide it along the bottom surface of the firebox. Remove the fan assembly through the Burner Pan cutout.
3. Installation is the reverse of these steps.

### ***Electrical Considerations***

All optional fan kits are equipped with a 120VAC, 60Hz, 0.4A blower.

NOTE: All electric connections are to be made in accordance with CSA Standard C22.1 – Canadian Electrical Code part I or with the National Electrical Code, ANSI/NFPA 70 (latest edition) and/or in accordance with local codes.

WARNING: Electrical Ground Instructions. This appliance is equipped with a three-pronged (grounding) plug for your protection against shock hazard and should be plugged directly into a properly grounded three-prong receptacle. Do not cut or remove the grounding prong from this plug.

**DO NOT CONNECT MORE THAN ONE [1] THERMAL SWITCH.**

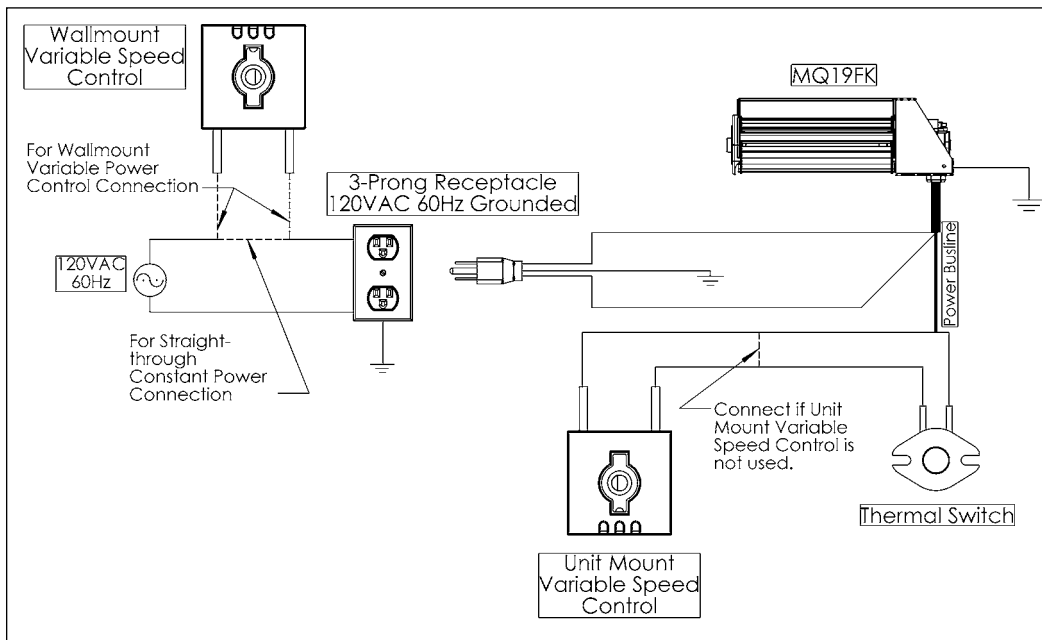
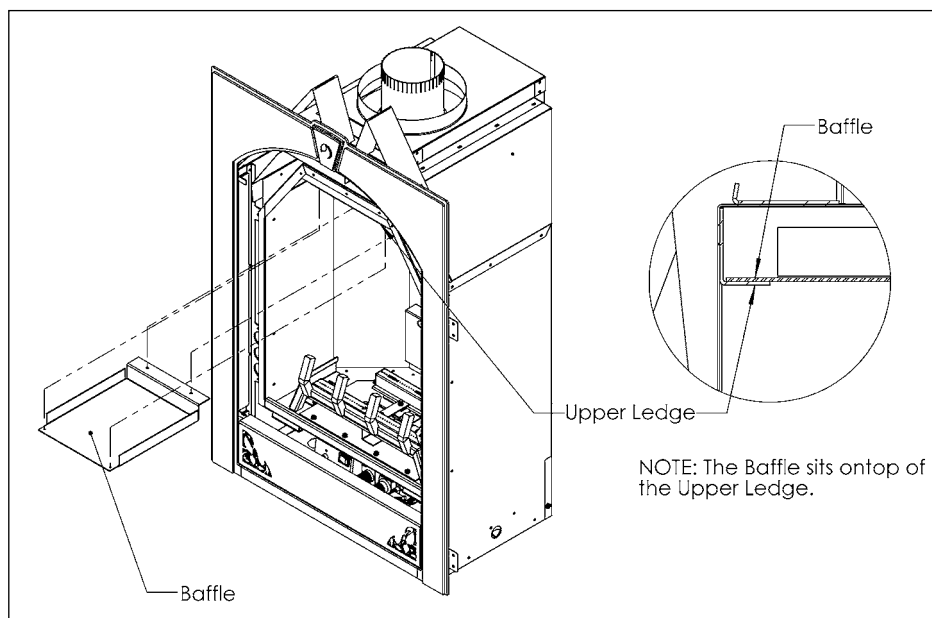

Figure 19 - Wiring diagram for a fan installation utilizing an unit-mount variable speed control.

## Baffle Replacement Guide

This unit requires a baffle to operate properly and efficiently. The baffle is fastened with four [4] screws to the inside of the firebox. Please make note of their location before beginning the replacement procedure.

**IMPORTANT:** Examine the condition of the mounting holes and screws. It is required that these areas are sealed properly. If the threads have been stripped or the mounting holes are oversized and cannot support the baffle, then replace the screws with an appropriate fastener that will ensure proper mounting and sealing. **DO NOT OPERATE THE UNIT WITHOUT A PROPERLY SEALED FIREBOX.**



## Gas Line Installation

This gas appliance should be installed by a qualified installer in accordance with local building codes and with current CAN/CGA - B149.1 or .2 installation codes for Gas Burning appliances and equipment in Canada and the National Fuel Gas Code ANSI Z223 in the U.S.A.

1. The gas pipeline can be brought in through either the left side or the bottom of the appliance. A knockout is provided at either location to allow for the gas pipe installation and testing of any gas connection.
2. The gas control inlet is 3/8" NPT. Typical installation layout for rigid pipe is shown at right.
3. When using copper or flex connector, use only approved fittings. Always provide a union so that gas line can be easily disconnected for burner or fan servicing. See gas specification for pressure details and ratings.
4. When a vertical section of gas pipe is required for the installation, a condensation trap is needed. See CAN/CGA-B149.1 or .2 for code details.
5. For natural gas, a minimum of 1/2" iron pipe with gas minimum pressure of 5.5" w.c. must be used for supply from the gas meter. Consult with the local gas utility if any questions arise concerning pipe sizes.
6. Ports are accessible for test gauge connection both on the inlet and outlet of the gas valve.
7. Turn the gas supply ON and check for leaks. **DO NOT USE OPEN FLAME FOR THIS PURPOSE.** Use an approved leak testing solution.
8. The appliance and its individual shutoff valve must be disconnected from the gas supply piping system during any pressure testing of that system at test pressures in excess of 1/2psig [3.5 KPa].
9. The appliance must be isolated from the gas supply piping system by closing its individual shutoff valve during any pressure testing of the gas supply piping system at test pressures equal to or less than 1/2psig [3.5 KPa].

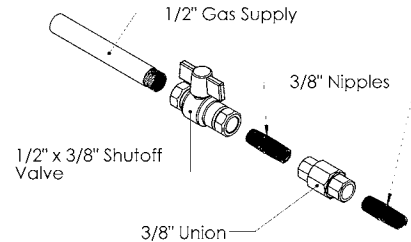

Note: The gas line connection may be made of 1/2" rigid pipe, 1/2" copper pipe or an approved flex connector. Since some municipalities have additional local codes, it is always best to consult your local authorities and the current CAN/CGA - B149.1 or .2 installation code in Canada or the National Fuel Gas code ANSI Z223.1 in the U.S.A.

For the state of Massachusetts a T-handle gas shut-off valve must be used on a gas appliance. This T-handle gas shut-off valve must be listed and approved by the state of Massachusetts. This is in reference to the state of Massachusetts state code CMR238.

**IMPORTANT:** Always check for gas leaks with a soap and water solution. **DO NOT USE OPEN FLAME FOR LEAK TESTING.**

Models	MQZDV1917N	MQZDV1917LP	
<b>Fuel</b>	Natural Gas	Propane	
<b>Gas Control</b>	Millivolt Adjustable	Millivolt Adjustable	
<b>Maximum Input</b>	11,800Lo / 17,000Hi	13,000Lo / 17,000Hi	
<b>Orifice Size (0-4500ft)</b>	#46	#55	
<b>Air Shutter</b>	1/16"	7/16"	
<b>Gas Inlet Size</b>	S.I.T. 820 Nova, 3/8" NPT		
<b>Gas Supply Pressure</b>	<b>Minimum</b>	<b>Normal</b>	<b>Maximum</b>
<b>Natural Gas</b>	5.5"	7"	9"
<b>Liquid Propane</b>	11"	11"	12"
<b>Manifold Pressure High</b>	3.5" w.c. [0.87KPa] NG		10" w.c. [2.61KPa] LP
<b>Manifold Pressure Low</b>	1.6" w.c. [0.40KPa]		6.3" w.c. [1.57KPa]

## Burner Removal/Service Guide

CAUTION: BEFORE STARTING REMOVAL OF PARTS TURN OFF GAS SUPPLY AND DISCONNECT ALL ELECTRICAL SUPPLIES.

**ALL WORK SHOULD BE PERFORMED BY A QUALIFIED AND CERTIFIED TECHNICIAN**

1. Remove Glass Door, Logs, Rocks, and Embers. Remove the Grate Bar Assembly by removing the screws located at G1 and G2. Remove the Burner Tube by removing the hold-downs located at B1 and B2. (See Figure 20.)
2. Remove the nine [9] screws mounting the Burner Pan assembly to the firebox. Tilt the pan forward and remove it from the unit.
3. Installation is the reverse of these steps.

NOTE: Before reinstallation, ensure that all old sealant material is scraped off and removed from the firebox bottom and burner pan. Verify that the sealing area is clean, and free of any grease and debris. Apply a fresh bead of high temperature sealant (e.g. Mil Pac) to the sealing area and ensure that there is a proper seal after the reinstallation.

WARNING: FAILURE TO PROPERLY SEAL THE FIREBOX WILL RESULT IN IMPROPER COMBUSTION AND/OR LEAKAGE OF TOXIC COMBUSTION GASES.

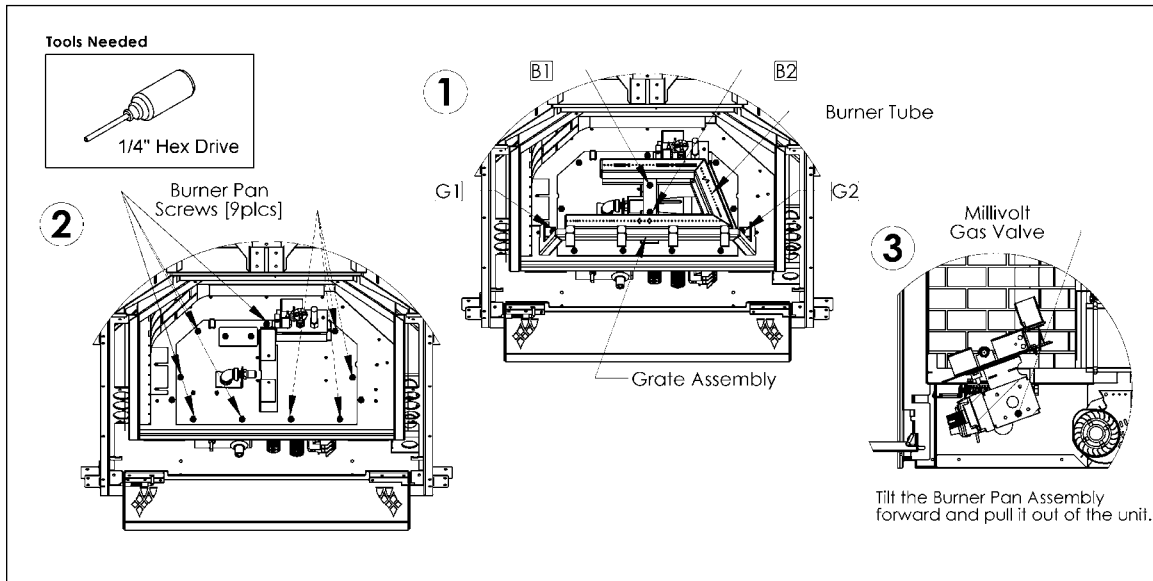

Figure 20 - Burner removal diagram.

## Liner Installation Guide

The installation procedure for the Liners is common between the brick and porcelain. One should note however, that no matter which is installed it is imperative that the panels be positioned tightly against the walls of the firebox to ensure proper combustion and operation.

**CAUTION: Before operating the appliance, any screws removed from the firebox should be returned to the original position to ensure proper sealing.**

1. Remove the glass door (see page 4).
2. Remove the Grate bar by unfastening the two [2] screws holding it in.
3. Remove just the burner tube by sliding it towards the right hand side.
4. If the Upper Clips [2] and Lower Panel Brackets [2] are preinstalled, then remove them.
5. Tilt the Back Panel backwards and slide it into place. The Back Panel should rest on the Air Restrictor.
6. Tilt the Side Panels sideways and slide it into the firebox. Rest the panels on the Firebox Bottom and tightly up against the wall.
7. Slide the Side Panels upwards so that the angled face is flush with the angled face of the firebox. Ensuring that the Back Panel is pinned securely, install the Lower Panel Brackets to prop the Side Panels in place.
8. Slide the Upper Clips so that the Side Panels are tightly secured onto the side walls of the firebox.
9. To remove simply reverse these steps.

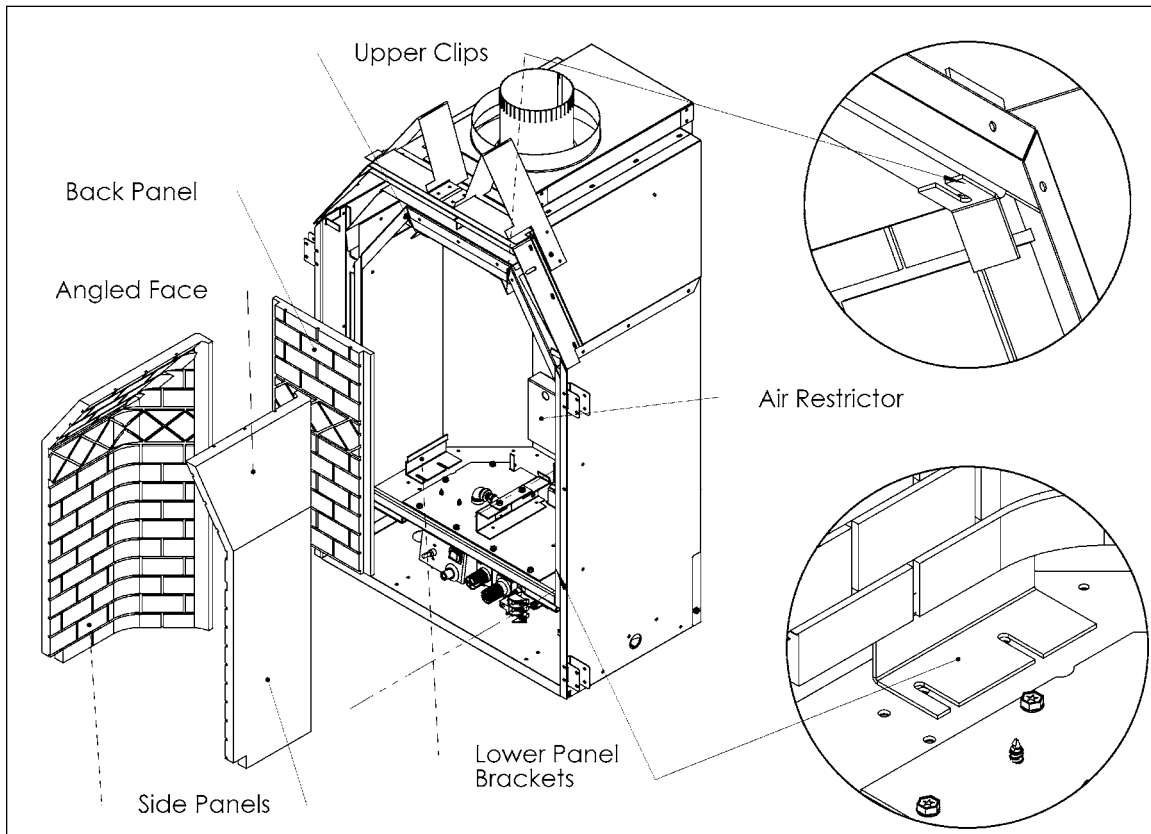

Figure 21 - Brick installation procedure.

# Millivolt System, Lighting, & Burner Control

## FOR YOUR SAFETY READ BEFORE LIGHTING

**WARNING: If you do not follow these instructions exactly, a fire or explosion may result causing property damage, personal injury or loss of life.**

### BEFORE LIGHTING

- A** This appliance has a pilot which must be lighted by hand. When lighting the pilot, follow these instructions exactly.
- B** Smell all around the appliance area for gas. Be sure to smell next to the floor because some gas is heavier than air and will settle on the floor.
- WHAT TO DO IF YOU SMELL GAS**
- Do not try to light an appliance.
  - Do not touch any electrical switch; do not use any phone in your building.
  - Immediately call your gas supplier from a neighbour's phone. Follow the gas supplier's instructions.
- If you cannot reach your gas supplier, call the fire department.
- C** Use only your hand to push or turn the gas control knob. Never use tools. If the knob will not push in or turn by hand, don't try to repair it, call a qualified technician. Force or attempted repair may result in a fire or explosion.
- D** Do not use this appliance if any part has been under water. Immediately call a qualified service technician to inspect the appliance and to replace any part of the control system which has been under water.

## LIGHTING INSTRUCTIONS

- Stop! Read the safety information above on this label.
- Set the thermostat to lowest setting.
- Turn off all electrical power to the appliance.
- Locate valve under the burner assembly.
- If the control knob is not already in the off position, ie. the word "OFF" in the 9 o'clock position, then push in the gas control knob slightly and turn clockwise to "OFF".  
NOTE: Knob cannot be turned from "PILOT" to "OFF" unless knob is pushed in slightly. Do not use force.
- Wait five (5) minutes to clear out any gas. If you then smell gas, STOP! Follow "B" in the safety information above on this label. If you don't smell gas then go to the next step.
- Now push in the control knob slightly and turn counter-clockwise to the "PILOT" position.
- Push in the control knob all the way and hold it. With the other hand push in the red ignitor button until you hear a click. Now observe closely the pilot burner located on the rear center-left hand side of the main burner. If a flame has appeared then continue to depress the control knob for 20 seconds. If the flame did not appear then continue to depress the red ignitor button every 5 seconds until a flame is established. NOTE: If after 30 seconds a flame has not yet been established then turn the control knob back to the off position and repeat steps 5, 6 & 7.
- Once the pilot has been established hold the control knob in the depressed position for approximately 25 seconds before releasing. If the flame goes out then repeat steps 7 and 8.
- Now turn the control knob to the "ON" position. The burner will not light unless the wall switch thermostat or remote control is turned "ON" or in the case of the thermostat there is a call for heat.
- Close the access door and turn all electric power back to the appliance.

## TO TURN OFF THE APPLIANCE

- Set the thermostat to lowest setting.
- Turn off all electric power to the appliance if service is to be performed.
- Open the control access door.
- Push in the gas control knob slightly and turn clockwise to the "OFF" position. Do not force.
- Replace control access panel.

### Recommended Maximum Lead Length (Double Wire) When Using Wall Switch or Thermostat

Wire Size	Max. Length
14 GA.	100 FT.
16 GA.	64 FT.
18 GA.	40 FT.
20 GA.	25 FT.
22 GA.	16 FT.

### Pilot Burner Adjustment

- Adjust pilot screw to provide proper sized flame.

**Caution: Do Not Wire 120 Volt Power To Millivolt Switches Or Thermostats.**

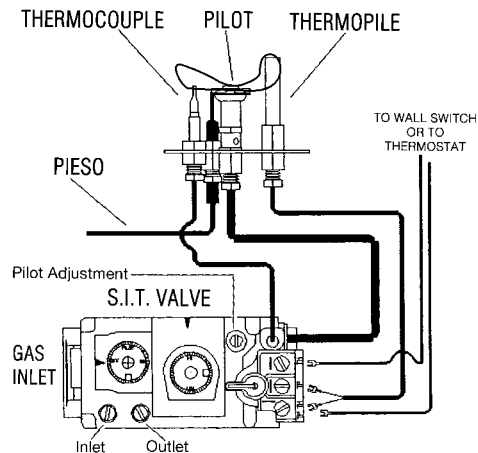

# Gas Conversion Instructions

## Section A Conversion Instructions

**WARNING:** This conversion kit shall be installed by a qualified service agency in accordance with the manufacturer's instructions and all applicable codes and requirements of the authority having jurisdiction. If the information in these instructions is not followed exactly a fire, explosion or production of carbon monoxide may result causing property damage, personal injury or loss of life. The qualified service agency is responsible for the proper installation of this kit. The installation is not proper and complete until the operation of the converted appliance is checked as specified in the manufacturer's instructions supplied with kit.

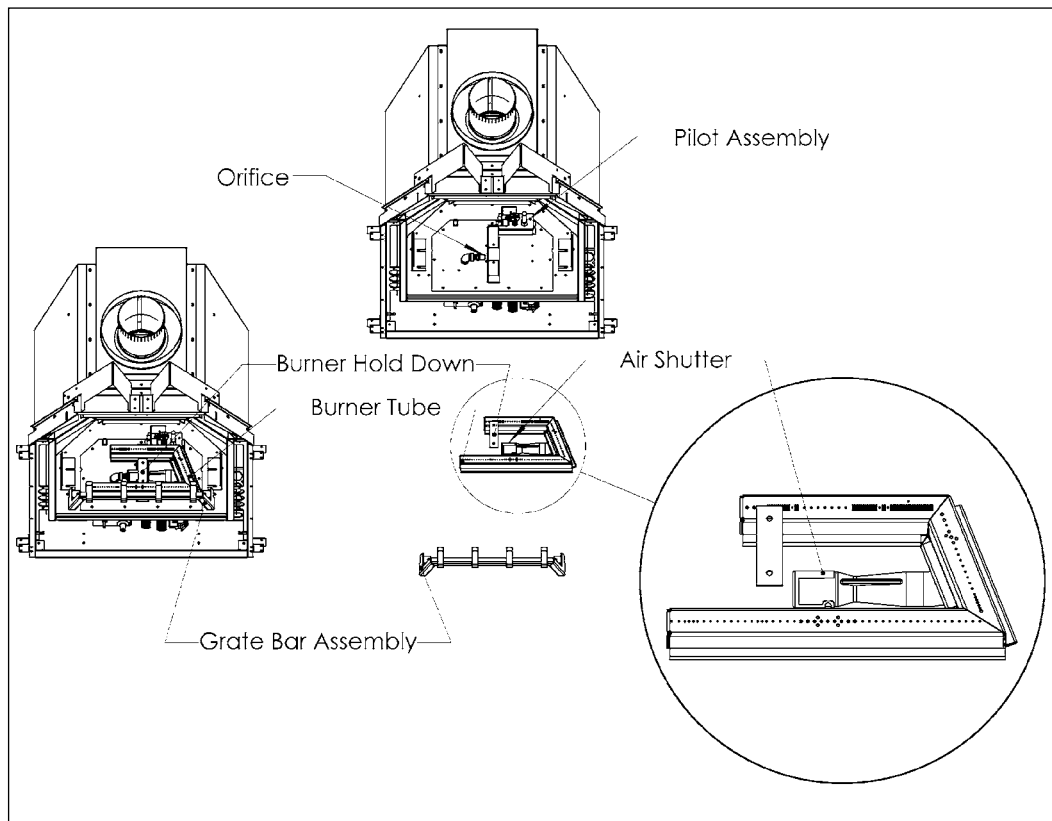

Figure 22 - Burner tube removal.

1. Remove the Grate Bar Assembly and Burner Hold Down.
2. Slide the Burner Tube to the right and remove it from the assembly. Make note of where the Air Shutter is and the screw used to secure it.
3. Remove the main orifice using a 1/2" wrench and replace it with the new conversion kit orifice.
4. Install new pilot orifice and Hi/Lo valve regulator by following the instructions supplied with the conversion kit (see Section B on the next page).
5. Adjust the primary air setting by changing the Air Shutter opening to the configuration specified in the manual (see page 4) or on the label plate. To adjust the air setting, loosen the screw on the Air Shutter and then rotate it to the correct opening. A drill bit or a tape measurer can be used as a gauge. Retighten the screw once the shutter is properly adjusted.
6. Reinstall the Burner Tube and Grate assembly by reversing steps 1 & 2.
7. Attach the new labels onto the bottom of the unit, writing information as needed.

# Section B Installation Instructions

## GAS CONVERSION KIT FOR TOP CONVERTIBLE PILOT SERIES 019065X



Instructions for converting SIT 190 series pilot burner injection from NG to LPG and from NG to LPG Only. This information should be considered as supplemental to the Appliance Manufacturer's Instructions.

### WARNING!

**The installation of this conversion kit must only be undertaken by a qualified and certified gas appliance installer.**

- 1 Shut off the gas supply to the appliance.
- 2 Allow the pilot burner to cool to room temperature.  
**WARNING: Touching a hot pilot burner can result in injury.**
- 3 The pilot hood is held in place by spring pressure. Remove the hood by pulling it directly up from the pilot bracket (1).
- 4 Insert a 5/32" or 4mm Allen wrench into the hexagonal key-way of the injector (2), and rotate it counter clockwise until it is free of the injector journal (3).
- 5 Verify that the new injector is proper for the application. The injector size is stamped on the side of the injector near the top. LPG injectors have a groove machined around their circumference near the top, while NG injectors do not have a groove (5). Refer to the Appliance Manufacturers instruction sheet for the proper injector size.
- 6 Insert the Allen wrench into the end of the injector. Then, insert into injector journal, and rotate the injector clockwise until a torque of 9 in-lbs. is achieved.
- 7 Replace the pilot hood by aligning the tab on the base of the hood with the slot in the side of the pilot journal, and push the hood down, directly onto the pilot bracket (4). The hood must sit squarely on the bracket for proper operation. Check to insure that the hood is properly seated onto the pilot bracket.
- 8 Proceed to Section A, Step 5.



fig. 1



fig. 2



fig. 3

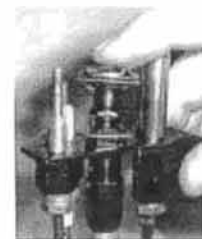

fig. 4

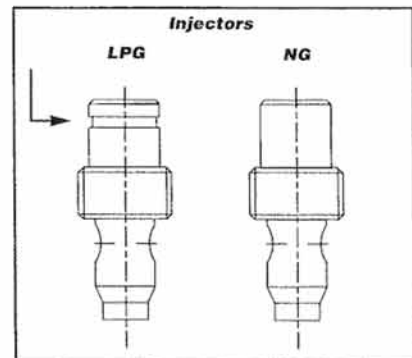

fig. 5

### WARNING!

**This conversion kit must only be applied as part of a conversion kit supplied by the appliance Manufacturer for the specific appliance, and type of gas being converted.**

**INSTALLER NOTICE. These instructions must be left with appliance.**



## Termination

It is imperative that the vent termination be located observing the minimum clearances as shown. There must not be any obstruction such as bushes, garden sheds, fences, decks or utility buildings within 24" from the front of the termination plate.

Do not locate termination where excessive snow or ice build-up may occur. Be sure to check vent termination area after snow falls and clear to prevent accidental blockage of venting system. When using snow blowers, make sure snow is not directed towards vent termination area.

## General Venting Information

This gas fireplace is approved to be vented either through the side wall or vertically through the roof. It is approved with Kingsman flex vent system and also approved for use with Simpson Dura-vent Direct Vent System (model DV-GS series), AmeriVent Direct Vent Pipe System, and Selkirk Direct Temp.

Kingsman flex vent system can be used with Simpson Dura-vent Direct Vent termination's (model DV-GS series). When using Simpson Dura-vent, AmeriVent Direct Vent pipe, or Selkirk Direct Temp a Kingsman / Dura-vent adapter must be used.

**ONLY VENTING COMPONENTS SPECIFICALLY APPROVED AND LABELED FOR THIS FIRE-PLACE MAY BE USED.**

Minimum clearance to combustibles on venting is 1" [2.5cm] with the following exceptions:  
Top of horizontal is 1-1/2" [3.8cm].  
Top of 90 degree elbow in an enclosure over 44" [112cm] is 2-1/2" [6.4cm].

Venting terminal shall not be recessed into a wall or siding.

## Venting Routes and Components

Since it is very important that the vent system maintain its balance between the combustion air intake and the flue gas exhaust, certain limitations as to vent configurations apply and must be strictly adhered to. The table (see Horizontal Vent Table on page 4) showing the relationship between vertical and horizontal side wall venting will help to determine the various vent lengths.

The maximum horizontal run with the 90 degree bend at the fireplace flue outlet is 4ft [122cm] (see Figure 24). The maximum horizontal run is 20ft [6.1m] when the vertical run is 7ft [2.1m] (see Figure 23). Note: 1/4" vertical rise is required for every 12" of horizontal run.

The maximum number of 45 degree bends per side wall installation is two [2] in the horizontal run and then you must reduce the length of the horizontal by 18" for each 45 degree bend.

The maximum vertical run is 40ft [12.2m].

**Special Note: For each 45 degree bend installed in the horizontal run, the length of the horizontal run must be reduced by 18" [46cm]. This does not apply if the 45 degree bends are installed on the vertical part of the vent system.**

### Example

If the length of the horizontal run is 10ft [3m], and two 45 degree bends are required, then the horizontal run length must be reduced to 7ft to achieve proper venting. If 10ft of horizontal run is required in conjunction with the two 45 degree bends, then the vertical run must be reduced appropriately. Please refer to Table 2 on page 4 for the relationship between horizontal and vertical runs.

Note that two additional 90 degree bends, or equivalent, are allowed. However, to do so the horizontal run must be reduced by 36" [91cm] for each 90 degree bend.

**IMPORTANT:** Always locate the fireplace in such a way that a minimum of offsets and/or horizontal runs are required. 1/4" vertical rise is required for every 12" horizontal run.

## Horizontal Vent Table

To use the Horizontal Vent Table (see Table 2), determine the total vertical height of the system and the number of bends required. Locate the value on the first column and then move across to see the corresponding maximum allowable horizontal run.

The Horizontal Vent Table has been established for 90° horizontal/vertical runs. Therefore, flex pipes that do not have 90° bends will not fall into this vent table relationship.

Total Vertical		Max. Horizontal			Total Vertical		Max. Horizontal	
Feet	Meters	Feet	Meters		Feet	Meters	Feet	Meters
4	1.2	5	1.5		14	4.3	20	6.1
5	1.5	8	2.4		15	4.6	20	6.1
6	1.8	12	3.7		16	4.9	20	6.1
7	2.1	20	6.1		17	5.2	20	6.1
8	2.4	20	6.1		18	5.5	20	6.1
9	2.7	20	6.1		19	5.8	20	6.1
10	3.0	20	6.1		20	6.1	20	6.1
11	3.4	20	6.1		25	7.5	15	4.6
12	3.7	20	6.1		30	9.0	10	3.0
13	4.0	20	6.1		40	12.2	0	0

Table 2 - Horizontal Vent Table

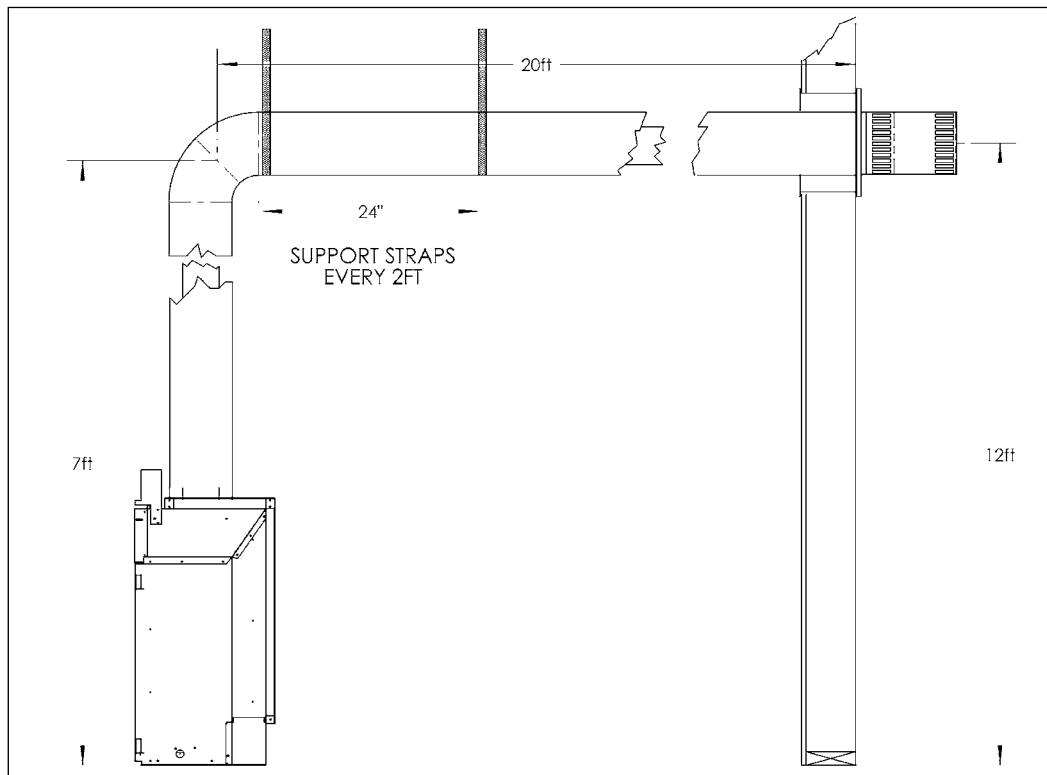

Figure 23 - Vent configuration illustrating maximum horizontal run of 20ft when vertical run is 7ft.

NOTE: The final location of the fireplace must be such that the horizontal vent dimensions fall within those stated on the graph. The Maximum Vertical vent run is 40ft [12.2m]. Please refer to Table 1 on page 4 for clearance to combustibles information.

It is recommended for **Propane Horizontal Installations** that the venting should be a minimum of one foot vertical off the flue before the elbow on any horizontal runs of one foot or greater. This allows for cleaner combustion and greatly reduces carboning and cleaning of glass. (Does not apply to Back Flue models)

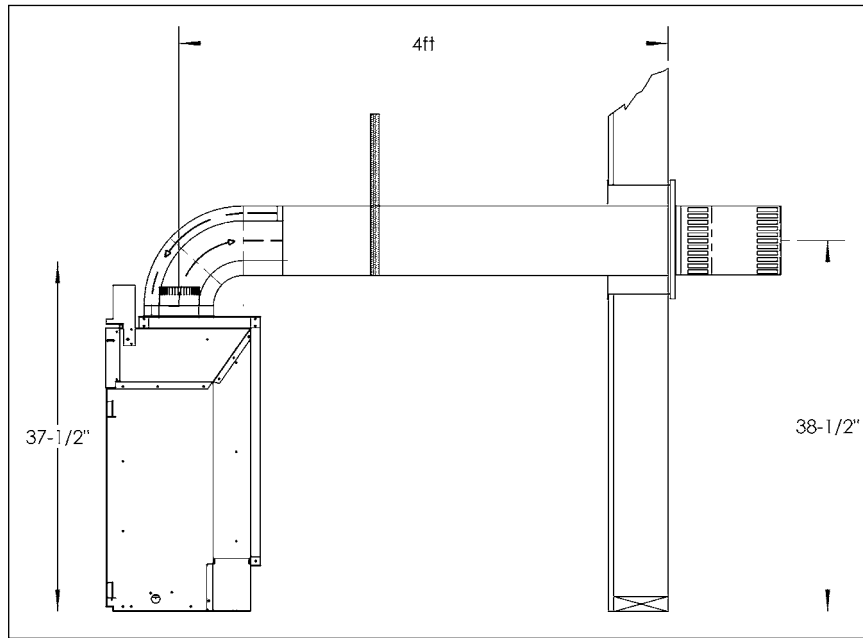

Figure 24 - Venting configuration illustrating vertical rise over 4ft horizontal run.

## General Vent Installation Information

This gas appliance is approved to be vented either through the side wall or vertically through the roof. Only Kingsman venting kits and components specifically approved and LABELED for this stove may be used. This appliance is also approved for use with Simpson Dura-vent Direct Vent system, Model DV-GS Series, and AmeriVent Direct Vent Pipe System.

### *Simpson Dura-vent, AmeriVent, and Selkirk Direct Temp*

When using Simpson Duravent, AmeriVent pipe, or Selkirk Direct Temp a Dura-vent adapter must be used (part # ZDVDFFA for fireplaces). Follow installation instructions provided by the appropriate manufacturer for installation of pipe, and adhere to the clearance to combustibles provided in this manual. Apply a bead of Mill Pac high temp sealant to all joints of pipes, adapters and termination as recommended.

**WARNING: DO NOT mix parts from different systems unless stated in the manual.**

### *Flex Pipe Venting*

Flex pipe is shipped in an unexpanded length. Therefore, when installing the pipe, expand it completely and then cut off the remaining length. A flex pipe can be expanded to twice their shipped length (e.g. 4ft. to 8ft).

Do not use more than 2 couplers to extend short pipes. Single sections are preferred in an installation attaching at the fireplace and termination.

Place the spring spaces provided approximately every two feet to stabilize 4" flex in the center of 7" flex. When forming bends place spring in bend or before and after (see Figure 25).

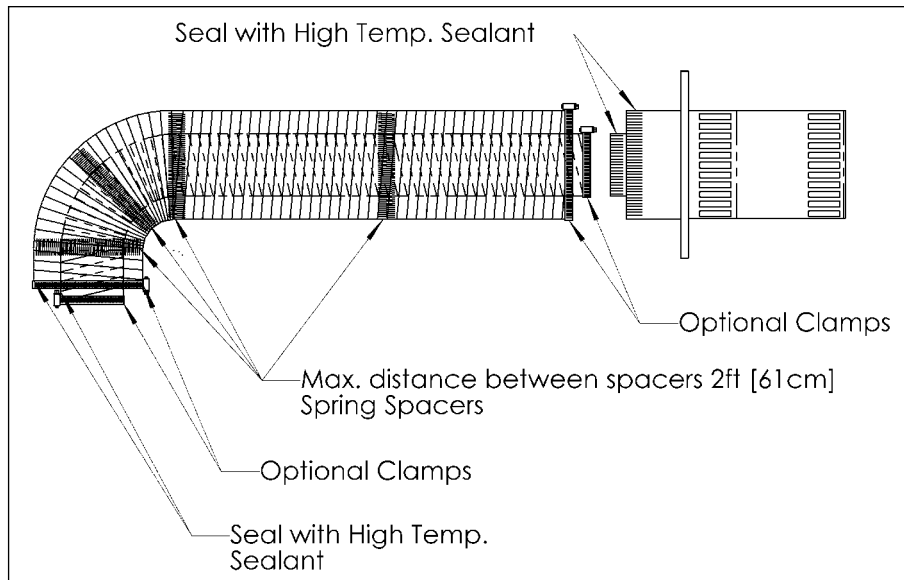

Figure 25 - Flex pipe spring spacing guide.

Horizontal runs require support metal straps every 2ft. In an offset installation support straps should be used to stabilize pipe.

Expand 4" and 7" flex pipe to the point that the 7" protrudes approximately 2 to 3 inches past outer wall and the 4" flex protrudes approximately 2 to 3 inches past the 7" flex. Attach the 4" pipe to the termination first and secure with sealant and screws then attach the 7" flex to the termination with caulking and screws. Termination may then be moved back to the outer wall and attached to home screwing into the framing. Use silicone around the termination to provide waterproof seal. If siding shield is going to be used attach this using same attaching hole as the top of termination after termination has been caulked for waterproofing.

## *Use High Temperature Sealant*

**NOTE:** It is critical to the proper and safe operation of this fireplace that on all connections the inner liner and the outer casing are both caulked with liberal amounts of sealant. Do not use any kind of tape or silicone other than that recommended in this manual. **Mill Pac Sealant**

Apply a bead of Mill Pac high temp sealant to all joints and use four screws to secure each pipe at fireplace, termination and any joint if joining any sections of pipe.

## Installation of Side Wall Venting

The minimum distance from the bottom of fireplace to centre of vent is 37-1/2" [95cm].

For combustible walls: Cut a hole through the wall allowing for an 11" x 11" (inside dimension) wall thimble. For a non-combustible wall: Cut an 8" diameter hole (see Figure 26).

Note that the clearance to combustibles is stated on pages 4.

Select the approximate vent length, precise measurements are not needed as your flex pipe can be expanded to twice its shipped length for ease of installation.

To install wall thimble centre over 11" x 11" framing from both sides of wall and secure. Route flex vent pipe through wall thimble (see Figure 5).

Before joining pipes, apply a bead of high temperature sealant (Mill Pac) to end of pipe. First attach the 4" flue pipe to the vent termination with sealant, and secure with the four screws provided. At this time make sure the spacer springs are attached to the 4" flex pipe as required. Then attach the 7" pipe by the same method.

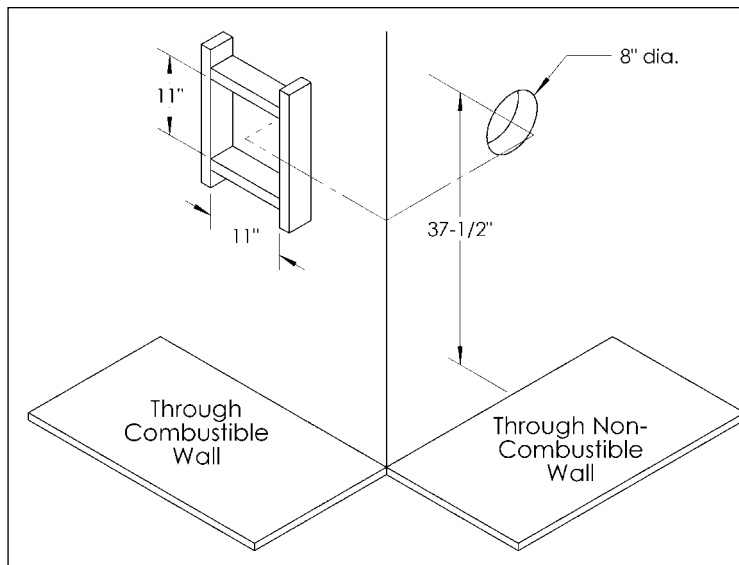

Figure 26 - Side wall hole dimensions for **flush wall installations**. For other installations where the unit is far away from the wall, ensure that the vertical rise is 1/4" for every 12" of horizontal run.

Mount vent termination and seal to wall using caulking around the wall thimble to weather proof. After installing the vent termination, double check to make sure the pipe extends properly through wall thimble and into vent termination.

Before joining pipes to fireplace flue, apply a bead of high temperature sealant (Mill Pac) to end of pipe. First attach the 4" flue pipe to fireplace with sealant, and secure with the four screws provided. At this time verify that the spacer springs are attached properly to the 4" flex pipe as required. Then attach the 7" pipe by the same method.

Support horizontal pipes every 2ft [61cm] with metal strap bands. Recheck fireplace to make sure it is leveled and properly positioned and secured. Support vertical pipes to maintain a minimum of 1" or greater clearance to combustibles with metal strapping bands.

Note: Vent Termination must not be recessed into wall or siding.

## ***Venting Straight Up Through Roof***

An Attic Insulation Shield must be installed where the vent passes from a lower living space into an attic space where the chimney is not enclosed. It is designed to keep insulation materials away from the chimney (see Figure 28a).

When installing the Attic Insulation Shield where the chimney passes from a living space to an attic space, install the shield from below and nail in place using 1" spiral nails.

A fire stop must be installed on the bottom side of the joists when passing through a ceiling or floor. If an attic insulation shield is to be used, a fire stop is not required.

## ***Using Flex Bends***

Avoid cutting joists by offsetting the flex pipe (see Figure 28b).

When using 45° bends a bend support is required directly above the highest bend.

When installing a bend in a joist area a minimum of 2-1/2" [6.4cm] clearance to combustible to the top of bend must be maintained, sides and bottom of pipe, a 1" [2.5cm] clearance to combustibles must be maintained. If running horizontal through an area a 1-1/2" [3.8cm] minimum clearance to the top of the horizontal pipe must be maintained.

Maximum vertical height of system should not exceed 40 feet [12.2m].

Use roof support and 7" rigid pipe at roof level. Flex not permitted within roof support.

When penetrating the roof a rigid 7" galvanized pipe must be used. Attach the 7" flex to the 7" rigid with high temperature sealant, secure with four screws assuring the flex and rigid pipe are secured. 4" flex pipe must be secured the same way with 4 screws but must penetrate the 4" flex and 4" section of termination. Attach 7" rigid pipe to 7" termination with sealant and screw with 4 sheet metal screws (see Figure 28c).

Vertical termination clearance is 18" [45.7cm] above the roof, measured from highest point of exit on the roof line.

Support vertical pipes to maintain minimum of one inch or greater clearances to combustibles

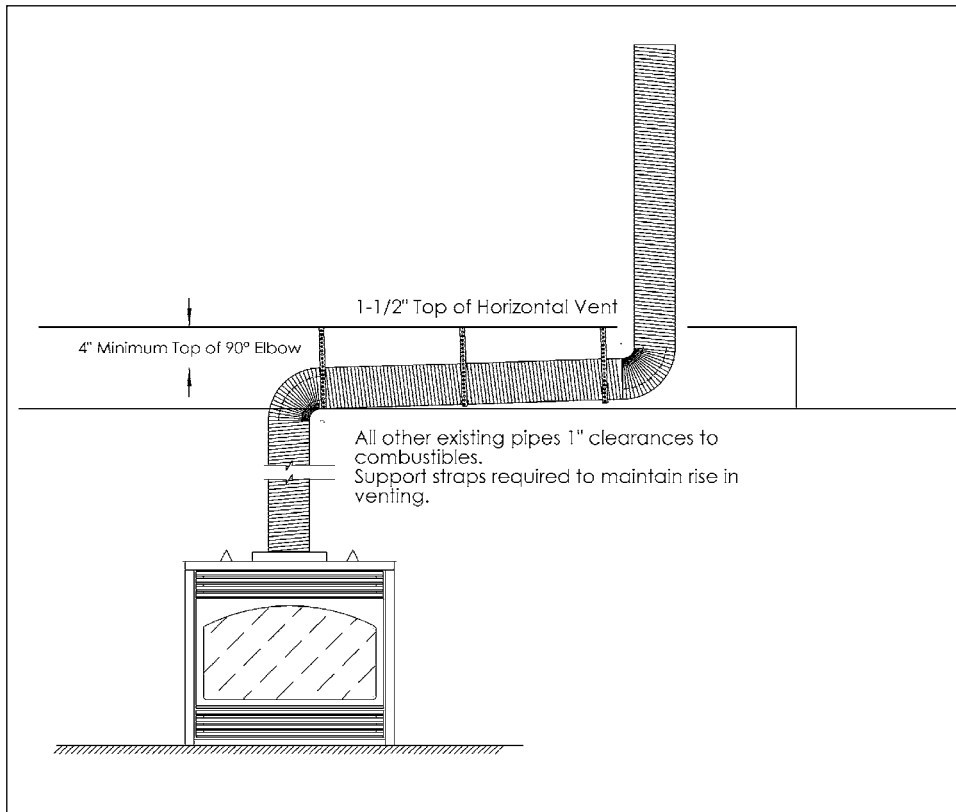

Figure 27 - Clearances in horizontal venting.

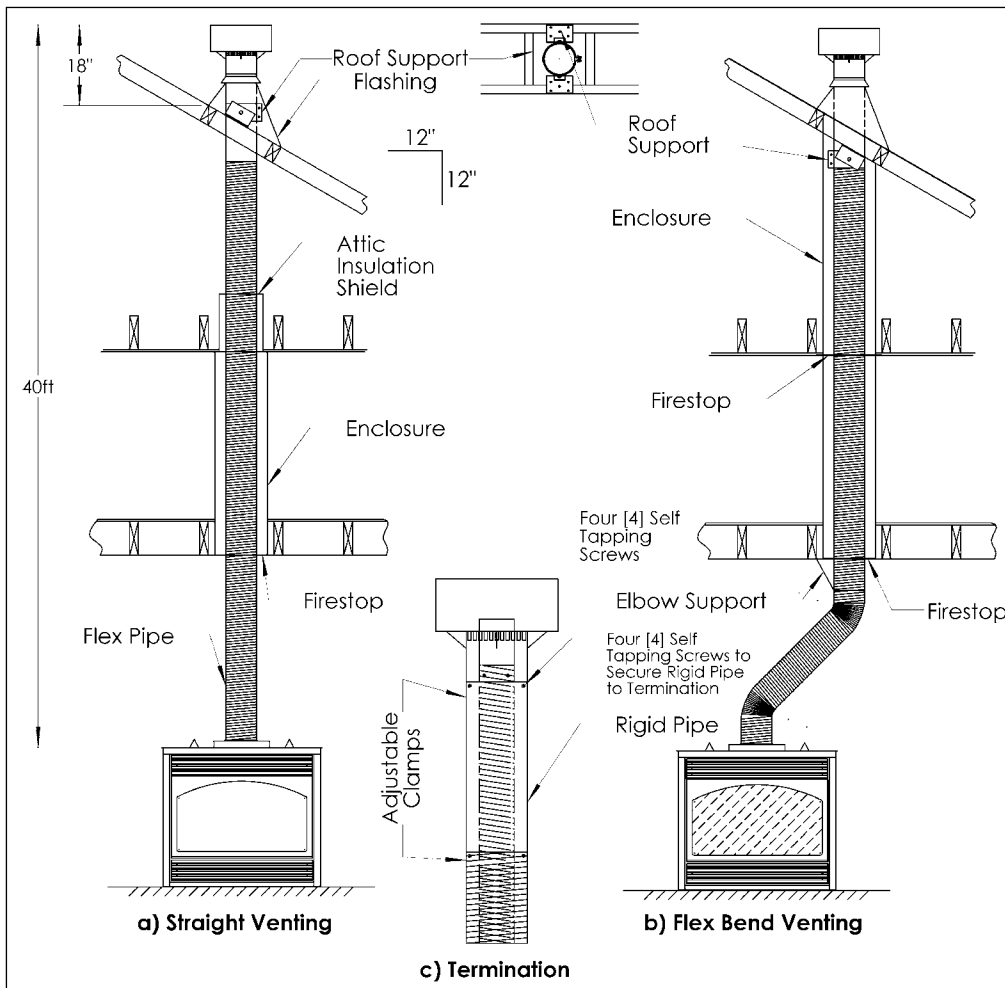

Figure 28 - a) Straight-through roof support configuration; b) Flex bend configuration; c) Termination mounting.

## Roof Flashing

Ensure that you have the proper roof flashing by checking your roof pitch using a level and two rulers, or by using a roof pitch card (see Figure 28a).

Slide a Roof Flashing suitable to your roof slope over the vent. Place the edge of the flashing plate that will be on the higher part of the roof slope under the shingles. Both the sides and the lower edge lay on top of the shingles.

**NOTE: At the top edge of the flashing plate, lift the shingles and nail the plate to the roof deck, then cement the shingles to the plate with a suitable waterproof mastic.**

Ensure that the chimney is plumb. Square up the flashing plate and nail in place to the roof deck. Use 12 nails with neoprene washers or cover the heads with a suitable waterproof mastic. Wrap the storm collar around the vent above the flashing. Secure the ends together loosely with nut and bolt supplied. Slide the collar down the vent until it comes in contact with the flashing. Tighten the bolt and seal the Storm Collar to the vent with a suitable waterproof non-combustible mastic.

The flashing and storm collar should be painted to match the roof shingles. This will extend its life and improve the appearance. Clean, prime and paint with suitable painting products.

# Log C-19 Placement Instructions

**WARNING:** Logs must be placed at their proper locations as shown in these illustrations. Failure to do so will result in improper combustion and emission of harmful gases, and can lead to personal injuries.

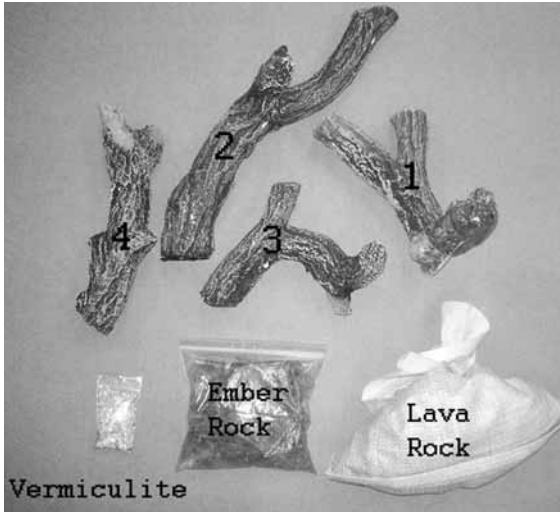

Figure 29 - Log C-19 parts list.

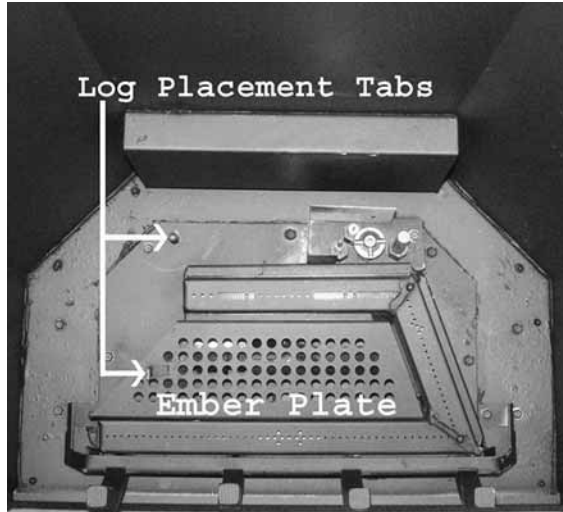

Figure 29 - Log C-19 parts list.



Figure 31 - Step 1. Place LOG #1 on the right side of the burner as shown.



Figure 32 - Step 2. Place LOG #2 on the firebox bottom log placement tab as shown.



Figure 33 - Step 3. Place LOG #3 onto the Log Placement tab located on the ember plate as shown.



Figure 34 - Step 4. Place LOG #4 on the sides of LOG #2 and #3 as shown.



Figure 35 - Step 5. Place Ember Rocks on the front burner tube and ember plate as shown. **DO NOT PLACE EMBER ROCKS ON THE REAR BURNER TUBE.**



Figure 36 - Step 6. Place Lava Rock on the bottom of the firebox in front and around the side of the burner tube. Sprinkle Vermiculite over top of the lava rock (for decoration only). **DO NOT PLACE LAVA ROCK OR VERMICULITE ON THE BURNER.**

## Parts List

### Serenity Zero Clearance Direct Vent Gas Fireplace – 19” Wide

Listed for USA/Canada, Tube Burner, Ceramic Glass, SIT Nova Valve with Hi/Lo Adjustment, Wall Switch, 4”/7” Top Flue, Framing 19-5/8W x 33H x 15D

MQZDV1917N	Fireplace Heater; Milli Volt (as above) Natural Gas; 17,000 BTU Approved for bedroom and mobile home.
MQZDV1917LP	Fireplace Heater; Milli Volt (as above) Propane; 17,000 BTU Approved for bedroom and mobile home.

### Finishing Surround

*Straight or Arch Surround (Required for Each Unit)*

MQ19SSBL	Surround – Straight – Black
MQ19SSPW	Surround – Straight – Pewter
MQ19SSCV	Surround – Straight – Vintage Copper Vein
MQ19SABL	Surround – Arch – Black
MQ19SAPW	Surround – Arch – Pewter
MQ19SACV	Surround – Arch - Vintage Copper Vein

### Grill and Arch Door Kit

*Diamond or Leaf Patter (Required for Each Unit)*

MQ19GDBL	Grill and Arch Door Kit – Diamond Pattern – Black
MQ19GDPW	Grill and Arch Door Kit – Diamond Pattern – Pewter
MQ19GDCV	Grill and Arch Door Kit – Diamond Pattern – Vintage Copper Vein
MQ19GLBL	Grill and Arch Door Kit – Leaf Pattern – Black
MQ19GLPW	Grill and Arch Door Kit – Leaf Pattern – Pewter
MQ19GLCV	Grill and Arch Door Kit – Leaf Pattern – Vintage Copper Vein

### Log/Rock Sets

*(Required for Each Unit)*

MQLOGC19	Cast Log Set – Split Oak
----------	--------------------------

### Accessories

MQ19FK	Fan Kit w/ Variable Speed (Temperature Sensing)
MQ19PL	Porcelain Reflective Panel Liner
MQ19RL	Brick Liner
Z1MT	Thermostat Millivolt Wall Mount
Z80PT	Thermostat Programmable Digital Millivolt
GFRC	Remote Control On/Off

GTRC	Remote Control - Thermostat
GTMR CN	Remote Control – Thermostat / Modulating – NG
GTMRCP	Remote Control – Thermostat / Modulating – LP
GTFR CN	Remote Control – Thermostat / Modulating / Fan – NG
GTFRCP	Remote Control – Thermostat / Modulating / Fan – NG

### Replacement Burner

*Assembly*

1917-BNGSI	Burner Assembly; Natural Gas C/W Millivolt Valve System for MQZDV1917N
1917-BLPSI	Burner Assembly; Liquid Propane C/W Millivolt Valve System for MQZDV1917LP

### Valve System Parts

1000-P136WR	Thermopile GOAI-524
1001-P069SI	Electrode Sparker and Cable 915.069 TC SIT
1001-P216SI	Thermocouple 290.216 TC SIT
1001-P165SI	Orifice Pilot NG 977.165 TC SIT
1001-P167SI	Orifice Pilot LP 977.167 TC SIT
1001-P633SI	Valve Nova LP Hi/Lo 0820651
1001-P634Si	Valve Nova NG Hi/Lo 0820652
1001-P713SI	Pilot Burner LP 199.713 TC SIT
1001-P714SI	Pilot Burner NG 199.714 TC SIT

### Miscellaneous Parts

1000-150GE	#SILICONE GE RED IS806 #736
1000-150MP	#HI-TEMP MILL PAC SEALANT
1000-214	#PIEZO-IGNITOR
1000-215	#PAL NUT (18MMX1.5MM)BLK
1000-216	#On/Off SWITCH
1000-255	#ORIFICE BRASS (State Size)
1000-EMBER	#DECORATIVE ROCK
2000-080	#THERMODISC 2450 (For Blower)
6000-P930	#BLOWER MOTOR QLN65/0018
2000-085	#CONTROL VARIABLE SPEED KBWC-13BV
1000-306	THERMALCORD – W/ADHESIVE
19ZDV-301	DOOR FRAME
19ZDV-310	CERAMIC GLASS
19MQ-P3815	STAINLESS STEEL GAS LINE
36HB-123	UPPER DOOR SPRING

### Conversion Kit (SIT Valve Only)

1917-CKLP	LP Conversion Kit
1917-CKNG	NG Conversion Kit

<b>Kingsman Fireplace Venting</b>	
ZDVHSK	Horizontal Vent Starter Kit-3' Length Horizontal Vent Termination, Wall Thimble, 36" Flex Pipe, Mill Pac, screws/washers, springs.
ZDVHSK5	Horizontal Vent Starter Kit-5' Length Horizontal Vent Termination, Wall Thimble, 60" Flex Pipe, Mill Pac, screws/washers, springs.
ZDVHKSQ	Horizontal Square Termination Vent Starter Kit - 3' Length Horizontal Vent Termination, Wall Thimble, Wall Thimble, 36" Flex Pipe, Mill Pac
ZDVHKSQ	Horizontal Square Termination Vent Starter Kit - 3' Length Horizontal Vent Termination, Wall Thimble, Wall Thimble, 36" Flex Pipe, Mill Pac
FDVVT40	Vertical Vent Termination
FDVHT	Horizontal Round Termination
FDVHSQ	Horizontal Square Termination
ZDVST	Horizontal Snorkel Termination (34" Tall, 24" Center to Center)
FDVHSCU	Safety Cage for Horizontal Termination
ZDVAIS	Attic Insulation Shield
ZDVVOS	Offset Support
ZDVFS	Firestop Spacer
ZDVRS	Roof Support
ZDVWT	Wall Thimble (Horizontal Venting)
ZDVSSLR	Siding Shield
ZDV48GP	Galvanized Pipe 7" Dia. x 48" (Vertical Installations)
ZDVAAF	Flashing 7" c/w Storm Collar (1/12 - 7/12)
ZDVAF2	Flashing 7" c/w Storm Collar (8/12 - 12/12)
ZDVAF3	Flashing 7" c/w Storm Collar Flat
ZDV7SC	Storm Collar 7"
ZDVFK5	Flex Kit (4" & 7" Dia.) 5'
ZDVFK8	Flex Kit (4" & 7" Dia.) 8'
ZDVFK20	Flex Kit (4" & 7" Dia) 20'
	*Kits are complete with spring stand- offs, screws, and Mill Pac
ZDV4FC	Flex Connector 4" Diameter
ZDV7FC	Flex Connector 7" Diameter
ZDV4SS	Spring 4" Standoff Spacer
ZDVDKA	Simpson Dura-Vent Adapter

## Troubleshooting the Gas Control System

**WARNING: BEFORE DOING ANY GAS CONTROL SERVICE WORK, REMOVE THE GLASS FRONT.**  
**NOTE: Before troubleshooting the gas control system, be sure external gas shut off is in the "On" position.**

Problem	Possible Causes	Corrective Action
Spark igniter will not light.	Defective or misaligned electrode at pilot.	Check for spark at electrode and pilot: if no spark and electrode wire is properly connected, replace igniter.
	Defective igniter (push-button).	Using a match, light pilot. If pilot lights, turn off pilot and push the red button again. If pilot will not light - check gap at electrode and pilot should be 1/8" to 1/4" to have a strong spark.
Pilot will not stay lit after carefully following lighting instructions.	Defective thermocouple (flame switch where applicable)	Check pilot flame. Must impinge on generator and thermocouple. Clean and/or adjust pilot for maximum flame impingement on generator and thermocouple. Replace thermocouple if pilot will not hold. (Hand tight 1/8 turn on replacement)
	Defective valve magnet.	Replace valve, if pilot won't hold after the thermocouple is replaced.
Pilot burning, no gas to burner, valve knob "ON", wall switch "ON".	Wall switch or wires defective.	Check wall switch and wires for proper connections. Jumper wire across terminals at wall switch. If burner and comes on, replace defective wall switch. If okay, jumper wires, across wall switch wires at valve. If burner comes on, wires are faulty or connections are bad.
	Generator may not be generating sufficient voltage.	Check generator with millivolt meter. Take reading at generator terminals of gas valve. Should read 325 millivolts minimum while holding valve knob depressed in pilot position and wall switch "off" Replace faulty generator if reading is below specified minimum.
	Plugged burner orifice.	Check burner orifice for stoppage and remove.
	Defective automatic valve operator.	Remove wall switch wires from gas valve. Install jumper wires from top bottom terminals of gas valve. Turn valve on "ON". If main burner does not light, replace valve.
Frequent pilot outage problem.	Pilot flame may be too low or blowing (high) causing the pilot safety to drop out.	Clean and/or adjust pilot flame for maximum flame impingement on generator and thermocouple.
Flame lifts off burner and goes out in less than 30 seconds.	Inner 4" liner has come off flue or termination, flame is starving for oxygen.	Attach 4" liner to flue or termination using screws, silicone and clamps as stated in manual.
Flame lifts off burner on one side while the rest of the flame remains lit.	Improper installation of firebrick. Firebrick is likely leaning.	Be sure to position firebrick against firebox walls and be sure to use brick clips attached to the inner side of firebox.



## LIMITED LIFETIME WARRANTY

This Limited Lifetime Warranty applies only while the unit remains at the site of the original installation and only if the unit is installed inside the continental United States, Alaska, Hawaii, and Canada. The warranty applies only if the unit is installed and operated in accordance with the printed instructions and in compliance with applicable installation and building codes and good trade practices.

### BASIC ONE YEAR WARRANTY

During the first year after installation, we will provide a replacement for any component part of your unit found to be defective in materials or workmanship, including labour costs. Repair work requires prior approval by Kingsman, labour costs are based on a predetermined rate schedule and any repair work must be done through an authorized Kingsman dealer.

### LIMITED LIFETIME WARRANTY

The heat exchanger, combustion chamber and burner of every Kingsman product excluding the Outdoor Firepit are warranted against materials or workmanship during the period the product is owned by the original owner. The part to be replaced must be returned to our distributor in exchange for the replacement part. Any labor, material, freight and/or handling charges associated with any repair or replacement pursuant to this Limited Lifetime Warranty will not be covered by this warranty.

### GENERAL TERMS

In lieu of providing a replacement part, we may, at our option, provide the distributor's component purchase price from us or a credit equal to the distributors component purchase price from us toward the purchase of any new unit which we distribute. If a credit is given in lieu of a replacement part, the rating plate from the unit being replaced must be submitted on a warranty claim, and the unit being replaced must be made available to our distributor for disposition.

In establishing the date of installation for any purpose, including determination of the starting date for the term of this Limited Lifetime Warranty, reasonable proof of the original installation date must be presented\*, otherwise the effective date will be based upon the date of manufacture plus thirty (30) days.

We will not be responsible for and you, the user, will pay for: (a) damages caused by accident, abuse, negligence, misuse, riot, fire, flood, or Acts of God (b) damages caused by operating the unit where there is a corrosive atmosphere containing chlorine, fluorine, or any other damaging chemicals (other than in a normal residential environment) (c) damages caused by any unauthorized alteration or repair of the unit affecting its stability or performance (d) damages caused by improper matching or application of the unit or the unit's components (e) damages caused by failing to provide proper maintenance and service to the unit (f) any expenses incurred for erecting, disconnecting or dismantling the unit (g) parts or supplies used in connection with service or maintenance (h) damage repairs, inoperation or inefficiency resulting from faulty installation or application (i) electricity or fuel costs or any increase in electricity or fuel cost whatsoever including additional or unusual use of supplemental electric heat.

We shall not be liable for any incidental, consequential, or special damages or expenses in connection with any use or failure of this unit. We have not made and do not make any representation or warranty of fitness for a particular use or purpose, and there is no implied condition of fitness for a particular use or purpose. We make no express warranties except as stated in this Limited Lifetime Warranty. No one is authorized to change this Limited Lifetime Warranty or to create for us any other obligation or liability in connections with this unit. Any implied warranties shall last for one year after the original installation. Some states and provinces do not allow the exclusion or limitation of incidental or consequential damages or do not allow limitations on how long an implied warranty or condition lasts, so the above limitations or exclusions may not apply to you. The provisions of this limited warranty are in additions to and not a modification of or subtraction from any statutory warranties and other rights and remedies provided by law.

Save this certificate. It gives you specific legal rights, and you may also have other rights which may vary from state to state and province to province.

In the event your unit needs servicing, contact your dealer or contractor who installed or serviced your unit. When requesting service, please have the model and serial number from each unit readily available. If your dealer needs assistance, the distributor is available for support and we, in turn support the distributor's efforts.

Fill in the installation date and model and serial numbers of the unit in the space provided below and retain this limited warranty for your files.

**Model No.** \_\_\_\_\_ **Serial No.** \_\_\_\_\_ **Date installed** \_\_\_\_\_

**Dealer or Contractor Name:** \_\_\_\_\_

\*To receive advantage of your warranty, you must retain the original records that can establish the installation date of your unit.