

# Jøtul F 600

Installation and Operating Instructions for USA/Canada	2
Montering- og bruksanvisning - Norsk	20
Installation and Operating Instructions- English	25
Manuel d'installation et d'utilisation- Francais	30
Instrucciones para instalación - Espanol	36
Manuale di installazione ed uso - Italiano	42
Montage- und Bedienungsanleitung - Deutsch	47
Installatie- en montagehandleiding - Nederlands	53



# USA/CANADA

## Installation and Operating Instructions for the USA

## Installation et fonctionnement pour Canada

**Safety notice:** If this solid fuel room heater is not properly installed, a house fire may result. For your safety, follow the installation directions. Contact local building or fire officials about restrictions and installation inspection requirements in your area. Kindly save these instructions for future reference.

**Avis de sécurité:** Une installation non appropriée de ce poêle de chauffage risque de provoquer un incendie. Assurez votre sécurité en respectant les directives d'installation suivantes. Consultez les autorités locales du bâtiment ou de la prévention des incendies au sujet des restrictions et exigences relatives aux inspections d'installations dans votre région

*Tested and listed by ITS, Intertek Testing Services, Middleton, Wisconsin.*

*Tested to U.S. Standards: ANSI/UL 1482 & 737, Canadian Standards: CAN/ULC-S627-M93*



### Standards:

*The Jøtul F 600 woodstove has been tested and listed to;*  
U.S. Standards: ANSI/UL 737 and ANSI/UL 1482.  
Canadian Standards: CAN/ULC-S627-M93

*Tests performed by:*  
ITS Intertek Testing Services, Middleton, WI

*Manufactured by:*  
Jøtul AS, P.O. Box 1411, N-1602 Fredrikstad, Norway

*Distributed by:*  
Jøtul North America, P.O. Box 1157, 400 Riverside Street,  
Portland, ME 04104

This heater meets the U.S. Environment Protection Agency's Emissions limits for wood heaters manufactured and sold after July 1, 1990.

Under specific test conditions, this heater has shown heat output at rates ranging from 13,500 to 45,900 BTU's per hour.

The Jøtul F 600 woodstove is **only** listed to burn wood. Do not burn any other fuels.

When installing, operating and maintaining your Jøtul F 600 woodstove, follow the guidelines presented in these instructions, and make them available to anyone using or servicing the stove.

A number of areas require a building permit to install a solid fuel burning appliance.

In the U.S., the National Fire Protection Association's Code, NFPA 211, *Standards for Chimneys, Fireplaces, Vents and Solid Fuel Burning Appliances*, or similar regulations, may apply to the installation of a solid fuel burning appliance in your area.

In Canada, the guideline is established by the CSA Standard, CAN/CSA-B365-M93, *Installation Code for Solid-Fuel-Burning Appliances and Equipment*.

Always consult your local building inspector or authority having jurisdiction to determine what regulations apply in your area.

**Jøtul North America Inc.**  
400 Riverside Street  
Portland, Maine  
USA

**Table of Contents:**

**Standards ..... 2**  
**Safety Notices ..... 3**

**Installation ..... 4**  
 Assembly before Installation ..... 4

**Chimneys ..... 4**  
 Masonry Chimneys ..... 5  
 Prefabricated Chimneys ..... 5  
 Chimney Height ..... 5  
 Wall Pass-throughs ..... 5

**Connecting to the Chimney ..... 6**  
 Masonry Chimney Thimbles ..... 6  
 Hearthmount into a Masonry Fireplace ..... 6  
 Prefabricated Chimneys ..... 6

**Clearances to combustibles ..... 7**  
 Floor Protection ..... 7  
 Clearances to Walls and Ceilings ..... 7  
 Using Shields to reduce Clearances ..... 7

**Alcove Installation ..... 8**

**Mobile Home Installation ..... 8**

**Operation ..... 8**  
 Controls on The Jøtul F 600 ..... 8  
 Breaking in your new Stove ..... 8  
 Starting and Maintaining a Fire ..... 9  
 Adding Fuel ..... 9  
 The Formation of Creosote ..... 9

**Maintenance ..... 10**  
 Glass Care ..... 10

**General Maintenance ..... 11**  
 Gaskets ..... 11

**Accessories ..... 11**  
 Firescreen ..... 11  
 Outside Air Kit ..... 11  
 Floor Bracket Kit ..... 12  
 Rear Heatshield ..... 12  
 Bottom Heatshield ..... 12  
 Stove -Top Thermometer ..... 12

**Figures ..... 13-14**

**Clearance Chart and Diagrams ..... 16-17**

**Parts Diagram ..... 18**

**Appendix A (alternate floor protection) ... 19**

**Safety notices:**

- Be sure to read this entire manual before you install or use your new Jøtul F 600 woodstove.
- If this room heater is not properly installed, a house fire may result. To reduce the risk of fire, follow the installation instructions. Failure to follow these instructions may result in property damage, bodily injury, or even death.
- Jøtul recommends that you have your new Jøtul F 600 installed by a professional installer of solid fuel burning appliances.
- Extremely hot while in operation! Keep children, clothing and furniture away. Contact may cause skin burns.
- Avoid creating a low pressure condition in the room where the stove is operating. Operating an exhaust fan or a clothes dryer could create a low pressure area, causing poisonous gases to come out of the stove into the room.
- You can prevent low pressure conditions by providing adequate combustion air within 24” but not closer than 12” from the stove. Or, simply install the optional outside air manifold system, which allows the direct connection of air from outside the house to the stove.
- Do not use chemicals or fluids to start the fire. Some fuels will, during combustion, separate carbon monoxide and generate it in the burn chamber. Carbon monoxide is toxic, so please follow the guidelines in this manual for proper operation of your Jøtul F 600.
- If you for some reason experience smoke “roll-out” from the stove, it may activate smoke detectors if installed in the house.

Save these instructions and make them available to anyone using or servicing the stove.

# USA/CANADA

## Installation:

If this solid fuel room heater is not properly installed a house fire may result. For your safety, follow the installation directions. Contact the local building or fire officials about restrictions and installation inspection requirements in your area.

### Reminder:

Your local officials have final authority in determining if a proposed installation is acceptable. Any requirement, that is requested by the local authority having jurisdiction, that is not specifically addressed in this manual, defaults to NFPA 211, and local codes in the U.S. or in Canada, CAN/CSA-B365-M and local codes.

## Assembly before installation

The Jøtul F 600 is shipped with the flue collar, gasketing and hardware inside the stove.

- To install the flue collar in the top or rear exit position remove the tape from the gasketing and adhere to the groove on the back of the stove around the flue opening.
- Place the flue collar on the stove in the top or rear exit position and secure with the nut, bolt and washer.
- The nut and washer are placed on the inside of the stove.

## Chimney connector

The chimney connector is a single walled pipe used to connect the stove to the chimney. For use with the Jøtul F 600, the chimney connector **must** be 6" in diameter, with a minimum thickness of 24 gauge black steel.

- Aluminum and Galvanized steel pipe is not acceptable for use with the Jøtul F 600. These materials cannot withstand the extreme temperatures of a wood fire and can give off toxic fumes when heated.
- **Do not use the connector pipe as a chimney.**
- Each chimney connector or stove pipe section must be installed to the stove flue collar and to each other with the male (crimped) end toward the stove. **See figure 2, page 13.**
- This prevents any amount of condensed or liquid creosote from running down the outside of the pipe or the stove top.
- All joints, including the flue collar connection must be secured with three sheet metal screws.
- For the best performance the chimney connector should be as short and direct as possible, with no more than two 90° elbows.
- **The maximum horizontal run is 36" and a recommended total length of stove pipe should not exceed 10 feet.**
- Always slope horizontal runs upward 1/4" per foot toward the chimney.
- No part of the chimney connector may pass through an attic or roof space, closet or other concealed space, or through a floor or ceiling.

- All sections of the chimney connectors must be accessible for cleaning.
- Where passage through a wall or partition of combustible construction is desired, the installation must conform with NFPA 211 or CAN/CSA-B365, and is also addressed in this manual.
- **Do not connect this unit to a chimney flue servicing another appliance.**

## Chimneys:

There are two types of chimneys suitable for the Jøtul F 600:

1. A code-approved masonry chimney with a flue liner.
2. A prefabricated chimney complying with the requirements for Type HT (2100°F) chimneys per UL 103 or ULC S629.

The chimney size should not be less than the cross-sectional area of the flue collar, and not more than three times greater than the cross-sectional area of the flue collar.

When selecting a chimney type and the location for the chimney in the house, keep this in mind: it is the chimney that makes the stove work, **not** the stove that makes the chimney work. This is because a chimney actually creates a suction, called "draft", which pulls air through the stove.

Several factors affect draft: chimney height, cross-sectional area (size), and temperature of the chimney, as well as the proximity of surrounding trees or buildings.

As a result, a short masonry chimney on the exterior of a house will give the poorest performance. This is because it can be very difficult to warm the chimney thereby creating inadequate draft. In extremely cold northern areas it may be necessary to reline the chimney or extend its height to help establish draft.

Conversely, a tall masonry chimney inside the house is easier to keep warm and will perform the best.

The following guidelines give the necessary chimney requirements based on the national code (ANSI-NFPA 211 for the US. And CSA CAN-B365 for Canada). However, many local codes differ from the national code to take into account climate, altitude, or other factors.

---

### Notice:

It is important that you check with your local building officials to find out what codes apply in your area before installing your new Jøtul F 600.

*Remember:* Your local inspector(s) have the final authority in approving your installation. It is always best to consult with them prior to the installation.

---

## Masonry Chimneys

When installing the Jøtul F 600 into a masonry chimney you must conform to all of the following guidelines:

- The masonry chimney must have a fireclay liner or equivalent, with a minimum thickness of 5/8" and must be installed with refractory mortar. There must be at least 1/4" air space between the flue liner and chimney wall.
- The fireclay flue liner must have a nominal size of 8" X 8", and should not be larger than 8" X 12". If a round fireclay liner is to be used it must have a minimum inside diameter of 6" and not larger than 8" in diameter.
- If a chimney with larger dimensions is to be used, it should be relined with an appropriate liner that is code approved.
- The masonry wall of the chimney, if brick or modular block, must be a minimum of 4" nominal thickness. A mountain or rubble stone wall must be at least 12" thick.
- A newly-built chimney must conform to local codes and in their absence must recognize national regulations. When using an existing chimney, it must be inspected by a licensed professional chimney sweep, fire official, or code officer, to ensure that the chimney is in proper working order.
- No other appliance can be vented into the same flue.
- An airtight clean-out door should be located at the base of the chimney.

## Prefabricated Chimneys

If a prefabricated metal chimney is to be used it must be a chimney type that is tested and listed for use with solid fuel burning appliances.

That means a chimney that is tested to the following:

High Temperature (HT) Chimney Standard UL 103 for the U.S. and High Temperature Standard ULC S-629 for Canada.

The manufacturer's installation instructions must be followed precisely. Always maintain the proper clearance to combustibles as established by the pipe manufacturer. This clearance is usually a minimum of 2", although it may vary by manufacturer or for certain chimney components.

## Chimney Height

Whether a masonry chimney or prefabricated metal chimney is used it must be the required height above the roof line.

*The requirement is:*

The chimney must be at least 3 feet higher than the highest point where it passes through the roof and at least 2 feet higher than the highest part of the roof or structure that is within 10 feet of the chimney, measured horizontally. See **figure 3, page 13.**

Chimneys shorter than 14 feet may not provide adequate draft. This could result in smoke spilling into the room from the stove when loading the stove, or when the door is open. In addition, inadequate draft can cause back puffing, which is a build up of gases inside the firebox.

Other times, chimney height can create excessive draft which can cause high stove temperatures and short burn times. Excessive drafts can be corrected by installing a butterfly damper. If you suspect you have a draft problem, consult your dealer.

## Wall Pass-throughs

When your installation unavoidably requires the chimney connector to pass through a combustible wall to reach the chimney, always consult your local building officials, and be sure any materials to be used have been tested and listed for wall pass-throughs.

### In the U.S.

The National Fire Protection Association's publication, NFPA 211, Standard for Chimneys, Fireplaces, Vents and Solid Fuel Burning Appliances permits four methods for passing through a combustible wall. Before proceeding with any method be sure to consult with your local building officials to discuss any local code requirements.

#### Common Method:

- When passing through a combustible wall to a masonry chimney this method requires the removal of all combustible materials from at least 12" around the chimney connectors proposed location. With a 6" round liner the minimum area required would be 31" x 31" square.
- The space is then filled with at least 12" of brick around a fireclay liner. Remember, the liner must be ASTM C35 or equivalent, with a minimum wall thickness of 5/8".
- It is important to remember to locate the pass-through at least 18" from the ceiling for proper clearance to combustibles.
- It will be necessary to cut wall studs, install headers, and construct a sill frame to maintain the proper dimensions and to support the weight of the brick.
- The bricks must be solid brick with a minimum of 3 1/4" thick (4" nominal).
- Refractory mortar must be used at the junction of the chimney and the pass-through liner. The pass-through liner must not penetrate the chimney liner beyond the inner surface of the chimney liner. Use extreme care when constructing the hole in the chimney liner, the tiles can shatter easily. See **figure 4, page 13.**

### In Canada

In Canada the standard has been established by the Canadian Standard Association. The installation must conform to CAN/CSA-B365, Installation Code for Solid Fuel Burning Appliances and Equipment. Before proceeding be sure to consult your local building inspector.

# USA/CANADA

## Common Method:

This method requires the removal of all combustible materials from at least 18" (457mm) around the chimney connector's proposed location. With a 6" round liner the minimum area required would be 43" x 43" square.

It is important to remember to locate the pass-through at least 18" from the ceiling to maintain the proper clearance to combustibles.

The space that is cleared of combustible materials must then remain empty. Sheet metal panels can then be used to cover the area. However, when using a panel on both sides of the wall each cover must be installed on noncombustible spacers at least 1" from the wall. If one panel of sheet metal is to be used it may be installed flush to the wall.

## See section 5.3.1 and 5.3.2 of CAN/CSA - B365-M91.

Consult your local building inspector, authorized Jøtul Dealer, NFPA 211 in the U.S. or CAN/CSA-B635 in Canada for other approved wall pass-through methods.

## Connecting to the chimney:

### Masonry Chimney Thimbles

When installing a Jøtul F 600 into a masonry chimney through a "thimble" (the opening through the chimney wall to the flue), the thimble must be lined with ceramic tile or metal and be securely cemented in place.

The chimney connector/stove pipe must slide completely inside the thimble to the inner surface or the flue liner. It may be necessary to make use of a thimble sleeve (a pipe with a slightly smaller diameter than standard stove pipe). This special pipe can be easily installed into a thimble. **See figure 5, page 14.**

Make sure the connector pipe or thimble sleeve does not protrude into the flue liner, thereby restricting the area the smoke has to flow through. This bottle-neck will have a negative affect on the chimney system.

The chimney connector should be sealed at the thimble with refractory cement and the stove pipe leading to the stove should have a minimum of three screws.

**Do not connect this stove to a chimney flue servicing another appliance of any kind.**

## Hearthmount Into a Masonry Fireplace

The Jøtul F 600 may be installed into a masonry fireplace provided the height of the opening is a minimum of 31".

When installing the Jøtul F 600 into a masonry fireplace, code requires that the fireplace damper plate be removed or securely fixed in the open position. A connector pipe must then extend from the stove's flue exit through the damper area of the fireplace and into the chimney tile liner. **See figure 6, page 14.**

The inside area of the flue liner must not be less than the area of the stove's flue exit, and cannot be more than three times greater than the cross sectional area of the stove's flue exit.

If the chimney liner is too large to accommodate the stove, an approved relining system must be installed to resize the flue.

A new sheet metal damper block-off plate must be installed around the connector pipe at the damper frame and sealed with the proper sealant (usually High-Temp Silicone).

Fireplace installation must also observe the proper clearances to surrounding trim and mantels (addressed in clearance section of this manual). In addition, fireplace installations must also adhere to the floor protection guidelines specified in the following section.

## Prefabricated Chimneys

When installing the Jøtul F 600 to a prefabricated metal chimney always follow the pipe manufacture's instructions and be sure to use the components that are required. This usually includes some type of "smoke pipe adapter" that is secured to the bottom section of the metal chimney and allows the chimney pipe to be secured to it with three sheet metal screws. **See figure 7, page 14.**

# Clearances to Combustibles:

## Floor Protection

Floor protection under the stove must be constructed of a non-combustible material for protection from radiant heat, sparks, and embers.

Individual sections of floor protection must be mortared together to prevent sparks from falling through to combustible materials. Any carpeting must be removed from under the floor protection.

### In the U.S. and Canada

The Jøtul F 600 must be installed on a non-combustible surface extending:

A minimum of **18" (460mm)** in front of the stove and the right side load door (measured from the legs).  
And **8" (200mm)** on the left side and back of the stove (measured from side and back panels).

This will result in a minimum floor protection of **55"W X 50"D**. See figure 8, page 14.

In a rear vent installation the floor protection must also extend under the stove pipe a minimum of **2" (50mm)** beyond either side of the pipe.

A hearth pad measuring **45" wide X 53" deep** can be used. However, use of the right side load door is prohibited when this size hearth is used; because access to the firebox is only allowed through a door that has a minimum of **18" (460mm)** of hearth protection.

**When constructing a new hearth or floor pad, consult appendix a at the back of this manual for alternate materials and methods.**

## Clearances to Walls and Ceilings

The following clearances have been tested to UL and ULC standards and are the minimum clearances specifically established for the Jøtul F 600.

The following diagrams give the required clearances you must maintain when installing the Jøtul F 600 near combustible surfaces. See pages 16-17.

A combustible surface is anything that can burn (i.e. sheet rock, wall paper, wood, fabrics etc.). These surfaces are not limited to those that are visible and also include materials that are behind non-combustible materials.

If you are not sure of the combustible nature of a material, consult your local fire officials. Contact your local building officials about restrictions and installation requirements in your area.

*Remember:* "Fire Resistant" materials are considered combustible; they are difficult to ignite, but will burn. Also "Fire-rated" sheet rock is also considered combustible.

## Using Shields to Reduce Clearances

**Pipe shields:** When using listed pipe shields to reduce the connector clearance to combustibles, it must start 1" above the lowest exposed point of the connect pipe and extend vertically a minimum of 25" above the top surface of the stove.

**Double wall pipe:** Listed double wall pipe is an acceptable alternative to connector pipe heatshields.

**Wall-Mounted Protection:** When reducing clearances through the use of wall mounted protection:

*In the U.S.* refer to NFPA 211, Standard for Chimneys, Fireplaces, Vents and Solid Fuel Burning Appliances, for acceptable materials, proper sizing and construction guidelines.

*In Canada,* refer to CAN/CSA-B365, Installation Code for Solid-Fuel Burning Appliances and Equipment, also for acceptable materials, proper sizing and construction guidelines.

**Stove Mounted Heatshield:** A stove rear heatshield has been specifically designed for the Jøtul F 600. Rear heatshield part # 154329.

**No other heat shield may be used.**

**See pages 16-17 for complete clearance requirements and diagrams.**

---

### Notice

*Accessories for wood stoves for clearance reduction have been developed by many manufacturers. If not following the methods of the installation codes, be sure that any accessory you choose has been tested by an independent laboratory and carries the laboratory's testing mark. Make sure to follow all of the manufacturer's instructions.*

*Always contact your local building inspector or fire officials about restriction and requirements in your area. Reminder, it is the local officials who have final authority in the installations approval.*

---

# USA/CANADA

## Alcove Installation:

The Jøtul F 600 can be installed in an alcove situation provided: **See figures 9 and 10, page 14.**

1. The stove must be installed with listed double walled pipe.
2. In a protected alcove installation both side walls and rear wall must be protected per NFPA 211 or CAN/CSA-B365. The wall protection must be elevated 1" from the floor and at least 1" off the combustible wall to allow for an air-flow.
3. The height of the wall protection including the bottom air space must be 48".
4. The bottom heatshield **is required in all** alcove installations.
5. If a listed (UL/ULC) hearth board is not used the hearth that is constructed must have a minimum r value of 1.6 (**see appendix a, page 19**).
6. Minimum ceiling height in an unprotected installation, off the top of the stove is 48" (1220mm). The minimum ceiling height off the top of the stove in a *protected* ceiling installation is 15" (380mm).

**Use of the right side load door is prohibited in alcove installations.**

## Mobile Home Installations:

The Jøtul F 600 has been approved for use in mobile homes in the U.S. and Canada, provided:

1. The stove is secured to the floor or the mobile home. Floor mounting kit #750304.
2. The stove is provided outside air for combustion. Outside Air kit #154333 (see page 11 for more details)
3. The stove must be grounded to the mobile home frame per NFPA 70.

*As always, consult with your local building inspector or fire officials about restrictions and requirements in your area prior to installing the stove.*

---

### **Warning:**

**Do not install in a bedroom/sleeping room. The structural integrity of the mobile home's floor, wall, ceiling/roof must be maintained.**

---

## Operation:

Before building a fire in your new Jøtul F 600, please read the following section carefully and completely.

This stove is designed to burn natural wood **only**. Wood that has been air-dried for a period of 6 to 14 months will provide the cleanest most efficient heat.

### **Do not burn:**

- |             |                              |
|-------------|------------------------------|
| * Coal      | * Treated or painted wood    |
| * Garbage   | * Chemical Chimney cleaners  |
| * Cardboard | * Colored paper              |
| * Solvents  | * Any synthetic fuel or logs |

The burning of any of these materials can result in the release of toxic fumes. Never use gasoline, gasoline-type lantern fuel, kerosene, charcoal lighter fluid, or similar liquids to start or "freshen-up" the fire. Always keep such liquids away from the heater at all times.

### **Important**

Never build or allow the fire to rest directly on the glass. The logs should always be spaced at least one inch from the glass to allow for proper air flow within the stove.

## Controls on The Jøtul F 600

A single air control lever controls the burn time and heat output of the stove. This primary air control lever is located on the front of the stove directly above the ashlip. The primary air lever controls the amount of air that enters the stove for combustion.

**When first starting or reviving the fire: The primary control lever should be at the far right position, which allows the maximum amount of air into the stove.**

The more air entering the stove, the hotter the fire, the shorter the burn time. Moving the lever to the left reduces the air-flow into the stove which prolongs the fire at a lower heat output. **See figure 11, page 15.**

## Breaking in Your New Stove

Your new Jøtul F 600 is constructed of cast iron and stove furnace cement. This type of construction requires the stove to be "broken-in" gradually so that heat expansion does not occur too quickly and cause damage.

Complete the following steps for the proper break-in procedure for the Jøtul F 600:

To monitor the stove's temperature, Jøtul recommends the use of a magnetic stove-top thermometer, *placed directly on the corner of the stove's top plate.*

1. Light a small fire, newspaper and kindling only, only allow the stove to reach a maximum surface temperature of 200°. Burn for approximately 1 hour.
2. Allow stove to cool to room temperature.
3. Light a second fire, allowing the stove to reach a maximum temperature of 300° for 1 hour.
4. Cool the stove to room temperature.
5. Light a third fire and gradually allow the stove to reach a surface temperature of 400°
6. Cool stove to room temperature. This completes the “break-in” procedure.

**Never allow the stove to exceed a 400° surface temperature during any “break-in fire” with the exception of the last “break-in” fire.**

**Note:** It is normal for a new painted stove to emit an odor and even smoke during its first several fires. This is caused by the seasoning of the high temperature paint and will diminish with each fire and will eventually disappear. Opening a window or door to provide additional ventilation will reduce the odor as this process takes its course.

## Starting and Maintaining a Fire

Burn only solid wood directly on the bottom grate of the stove, do not elevate the fire in any way.

- The ash pan door on the stove must always be securely closed when the stove is in operation.
- Burning the stove with the ash pan door open will overfire the stove and cause interior damage.
- With the primary air control lever in the full open position, start with several sheets of crumpled newspaper placed directly on the grate. On top of the newspaper, place several pieces of small dry kindling (approx. 1” in diameter) with two to three larger logs (approx. 3” to 5” in diameter) on top.
- Light the fire and close the door, slowly building the fire by adding larger and larger logs. Be sure to follow the break-in procedure before creating a fire that will damage the stove.
- Once the stove has reached a surface temperature range of between 400° and 600°, adjust the primary air control lever as necessary to generate the heat output and burn time desired.
- Jøtul recommends the use of a magnetic stove top thermometer to monitor the surface temperature of the stove. The optimum surface temperature range for the most efficient burn is between 400° to 600°. See **figure 12, page 15**, for the optimum locations of a stove-top thermometer.

## Adding Fuel

When reloading the stove while it is still hot and a bed of hot embers still exist, follow this reloading procedure:

- Always wear gloves when tending to the stove.
- Push the air control lever to the full open position (far right).
- Wait a few seconds before opening the door.
- Use a stove tool or poker to distribute the hot embers equally around the firebox.
- Load the fuel, usually with smaller logs first.
- Close the door, be sure to latch the door tightly.
- Wait 5 – 10 minutes before adjusting the primary air to the desired heat output setting. (If you have at least a 2” thick ember bed when reloading, it may be possible to close the door and immediately adjust the air control setting).

## The Formation of Creosote

When wood is burned slowly and at low temperatures, it produces tar and other organic vapors, which combine with moisture to form creosote. The slow moving smoke carries the creosote vapors, which condense in the cooler chimney flues, and this creosote then sticks to the chimney walls.

The creosote that accumulates in the chimney is highly flammable and is the fuel of chimney fires. To prevent chimney fires it is important to have the chimney and chimney connector pipe inspected and/or cleaned semi-annually. A qualified chimney sweep or other authorized service person can provide this service.

It is also important to remember that chimney size, temperature and height all affect draft which in turn affects the formation of creosote. Be sure to follow the installation and operation guidelines established in this manual.

# USA/CANADA

## Maintenance:

**For your protection always wear safety gloves when handling the ash pan.**

Ash removal will be required periodically depending on how frequently the stove is used. Conveniently, the Jøtul F 600 is equipped with an ash pan assembly for easy ash removal, without the need for opening the front doors.

The ash pan door is located under the front ashlip of the stove. To open the ash door rotate the door knob counterclockwise to unlatch the door and clockwise to latch the door.

Remove the ash pan. When the stove is in operation always close the ash door before leaving to dispose of the ashes.

The ashes should be placed in a metal container equipped with a tight sealing lid. The container should be placed on a noncombustible floor or on the ground, well away from all combustible materials, pending final disposal. If the ashes are disposed of by burial in soil or otherwise locally dispersed, they should be retained in the closed container until all cinders have thoroughly cooled.

## Glass Care

### Cleaning:

On occasion it will be necessary to clean the carbon deposits and fly ash off of the glass. If the carbon and fly ash are allowed to remain on the glass for an extended period of time it could eventually cause the glass to become etched and cloudy. Any creosote, which might deposit on the glass, should burn off during the next hot fire.

*The proper cleaning procedure is as follows:*

1. Glass needs to be completely cool.
2. Only use a cleaner that is specifically designed for this purpose. The use of abrasives will damage the glass and ultimately leave the glass frosted.
3. Rinse and dry glass completely before burning your stove.

**Never operate the stove with a cracked or broken glass panel.**

### Glass removal:

Always operate the doors slowly and cautiously to avoid cracking or breaking the glass. Never use the door to push wood into the firebox. If the glass becomes cracked or broken follow this procedure for replacement:

1. Remove the door from the stove and place on a flat surface.
2. Carefully remove all of the glass clips from the inside

of the door.

3. Gently remove all pieces of the glass panel and gasketing.
4. Remove all remaining debris from the glass area using a wire brush.
5. Apply a small bead of gasket/stove cement and the new gasket. Do not overlap the ends of the gasket rope.
6. Center the new glass panel over the gasket and reinstall the glass clips. **See figure 13, page 15.**

**Important:** The side of the glass treated with an infrared coating (marked on the perimeter) should always be facing outward. It is extremely important to tighten the glass clips slowly and in a repeating pattern, like tightening the lugs on an automobile wheel.

It may be necessary to retighten the glass clips after the stove has burned and the gasketing has been seated.

### Important:

Replace glass only with a ceramic glass panel specifically designed for the Jøtul F 600. Do not use substitutes. Replacement glass panels can be ordered through your Jøtul dealer.

## General maintenance

Like your car, regular maintenance prolongs the life of your stove. The following procedures do not take long and are generally inexpensive, but when done consistently, increase the life of your stove and in turn, increase your years of enjoyment.

At least once a year you should perform the following maintenance procedures:

1. Thoroughly clean the stove. Enamel surfaces should be cleaned with soap and water.
2. Empty stove of all soot and ashes. Only use a vacuum for this job if the vacuum is specifically designed for ashes.
3. Inspect the stove: Using a strong light inspect the stove inside and out for cracks or leaks. Replace all cracked parts and repair any cement leaks with furnace cement.

## Gaskets

Check door and window gaskets for tightness.

To check the seal of the front doors, close and latch the doors on a dollar bill and slowly try to pull the dollar bill free. If it can be easily removed then the seal is too loose. Check several spots around the door, and repeat the procedure on the ash pan door as well.

- If gaskets need to be replaced, scrape out the old gasket and cement and clean the area with a wire brush.
- Apply a small bead of cement and push in the new gasket.
- After closing and latching the doors wipe clean any excessive cement that has come from beneath the gasketing.

Description	Size	Length
Right door,	ld375	ø9,5 mm (3/8") 900 mm (36")
Left door,	ld375	ø9,5 mm (3/8") 900 mm (36")
Left door, middle	ld250	ø6,4 mm (1/4") 410 mm (18")
Right glass,	ld250	ø6,4 mm (1/4") 1050 mm (42")
Left glass,	ld250	ø6,4 mm (1/4") 1050 mm (42")
Ash pan door,	ld250	ø6,4 mm (1/4") 1100 mm (45")
Right side load door,	ld375	ø9,5 mm (3/8") 1400 mm (56")

The Jøtul F 600 is designed to burn cleanly and efficiently when used according to the guidelines expressed in these operating instructions. However, to maintain the proper performance, a yearly chimney inspection and cleaning is necessary. Failure to keep the chimney system free of creosote and build up could result in a serious chimney fire.

## Accessories:

Many accessories have been manufactured for use with the Jøtul F 600. Only use accessories that are specifically designed for the Jøtul F 600.

## Firescreen

The Jøtul F 600 has been approved for use as an open fireplace, with front doors open. This feature is especially nice when the ambience of a fire is desired. Some care should be taken when operating the stove as a fireplace.

- Always have the firescreen in place, attached to the stove front.
- Never over load the stove: For the best appearance burn in the traditional three log configuration.
- Reminder, when burning the stove with the screen in place, you are sacrificing efficiency for aesthetics, and you will be consuming wood at a much faster rate.

**Warning: Operate your Jøtul F 600 with the front doors fully open and the firescreen in place or fully closed. Partially opened doors may result in overfiring. Also, if doors are left partly open, gas and flame may be drawn out of the stove opening, creating risks from both fire and smoke.**

## Outside Air Kit

In certain installations it may be necessary to provide outside air to your Jøtul F 600 wood stove. Guidelines to determine the need for additional combustion air may not be adequate for every situation. If in doubt, it is advisable to provide additional air.

The outside air kit includes an adapter to mount onto the stove that will accept the fresh air pipe. Installation will require some additional materials:

- A. The appropriate length of metallic pipe for a conduit of the outside air (4" diameter).
- B. A rain/weather resistant cap for the outside of the house.
- C. A rodent screen - that is no larger than 1/4" mesh.

## Outside air may be required if:

1. The Jøtul F 600 does not "draw" steadily, smoke rollout occurs, fuel burns poorly, or back-drafts occur whether or not there is combustion present.
2. Existing fuel-fired equipment in the house, such as fireplaces or other heating appliances, smell, do not operate properly, suffer smoke roll - out when opened, or back-draft whether or not there is combustion present.
3. Opening a window slightly on a calm (windless) day alleviates any of the above symptoms.
4. The house is equipped with a well-sealed vapor barrier and tight fitting windows and/or has any powered

## USA/CANADA

- devices that exhaust house air.
5. There is excessive condensation on the windows in the winter.
  6. A ventilation system is installed in the house.

If these or other indications suggest that infiltration air is inadequate, additional combustion air should be provided from the outdoors. Outside combustion air can be provided to the appliance by the following means:

**Direct connection:** The Jøtul F 600 has been tested and listed for use with an outside air kit. This outside air kit is connected directly to the stove. Be sure to follow the instructions provided with the kit.

**Indirect method:** Outside air is ducted to a point no closer than (12") 300mm from the appliance, to avoid affecting the performance of the appliance.

**A mechanical ventilation system:** If the house has a ventilation system (air change or heat recovery):

A. The ventilation system may be able to provide sufficient combustion make-up air for the solid fuel fired appliance.

B. The homeowner should be informed that the ventilation system might need to be rebalanced by a ventilation technician after installation of the appliance.

### Floor Bracket Kit

Use of the floor bracket kit is required in all mobile home installations to secure the stove to the floor. Complete installation instructions and diagrams are supplied with each floor bracket kit.

### Rear Heatshield

A stove rear heatshield has been specifically designed for the Jøtul F 600 to reduce clearances off the rear of the stove to combustible materials. Use of the heatshield **does not** affect the clearance off the sides of the appliance.

See pages 11-12 for specific clearance requirements. Complete installation instructions are supplied with the heatshield. No other type of heatshield may be used on the rear of the Jøtul F 600.

### Bottom Heatshield

A bottom heatshield has been specifically designed for the Jøtul F 600. It is required in all alcove installations. Use of the bottom heatshield **does not** affect the floor protection requirements described on page 9 of this manual. No other type of heatshield may be used on the bottom of the Jøtul F 600.

### Stove-top Thermometer

Jøtul recommends the use of a magnetic stove-top thermometer to monitor the surface temperature of the stove. The optimum surface temperature range for the most efficient, clean burn is between 400° and 600°.

Fig. 1a

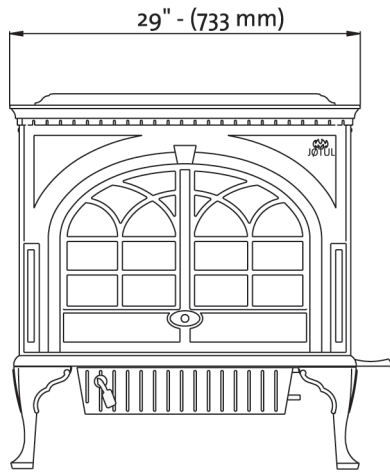

Fig. 2

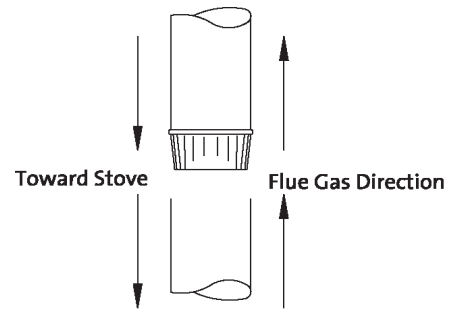

Fig. 1b

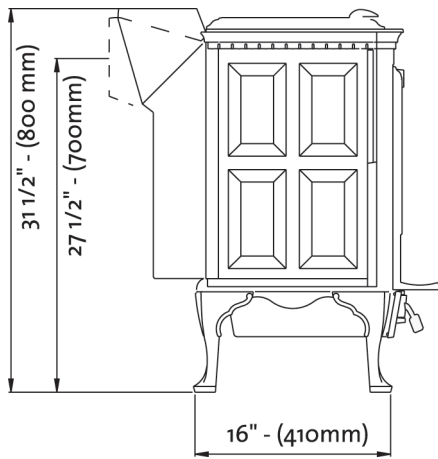

Fig. 3

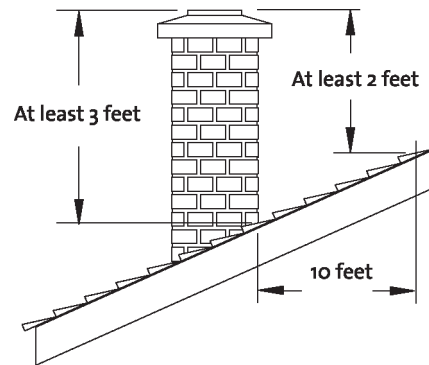

Fig. 1c

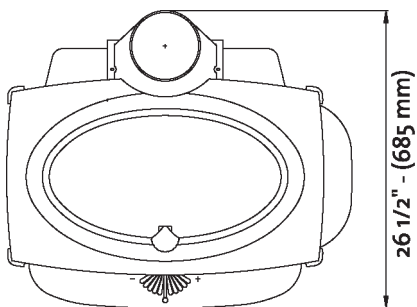

Fig. 4

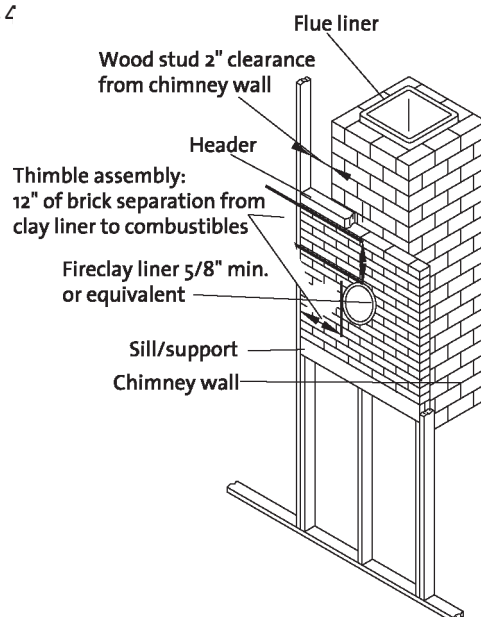

Fig. 5

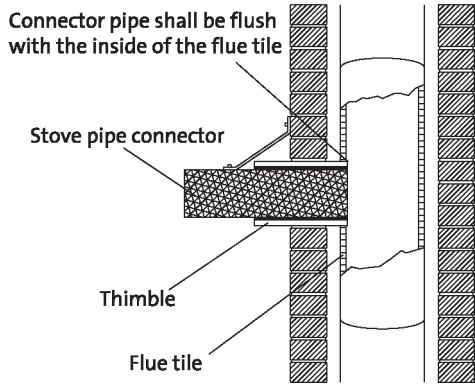

Fig. 8

### Hearth Protection

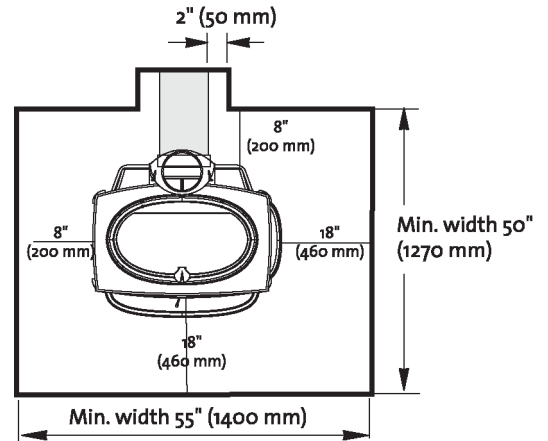

Fig. 6

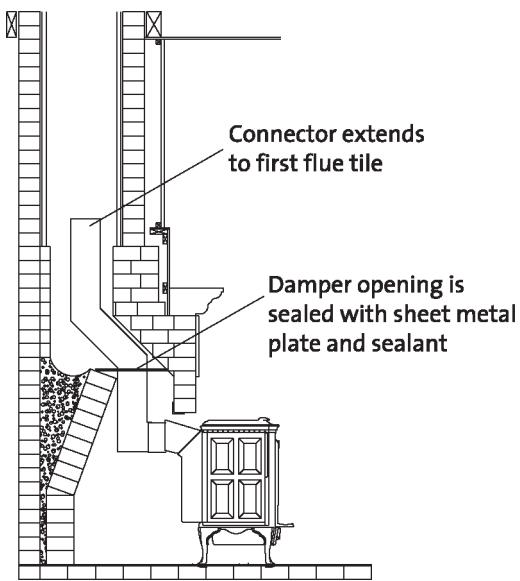

Fig. 9

### Unprotected Alcove Installation

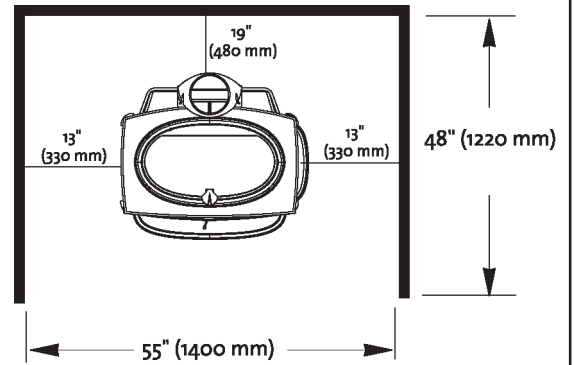

Fig. 7

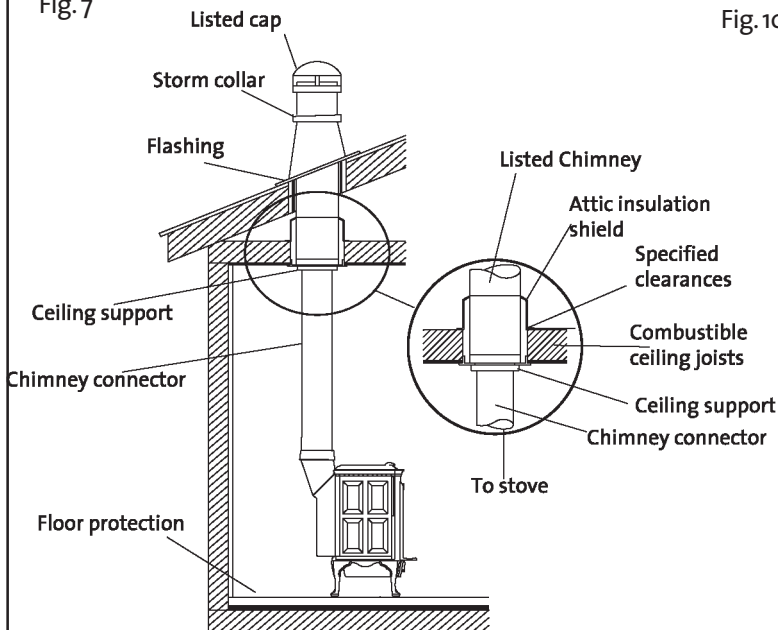

Fig. 10

### Protected Alcove Installation

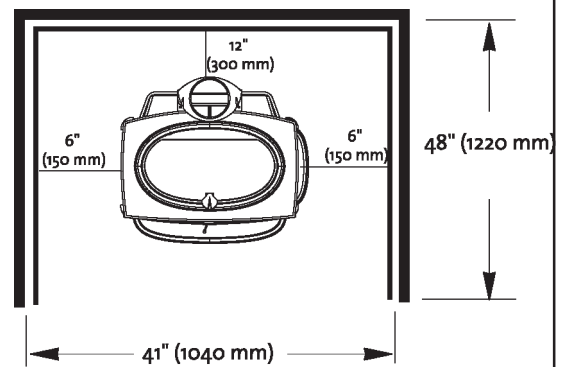

Fig.11

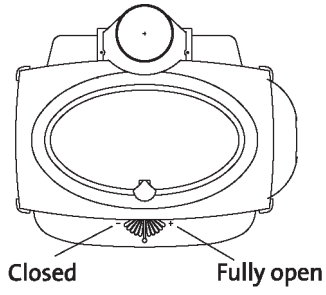

Fig.12

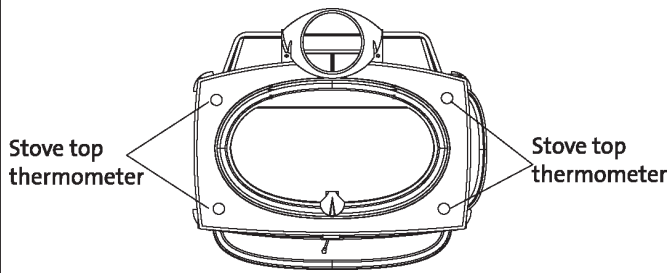
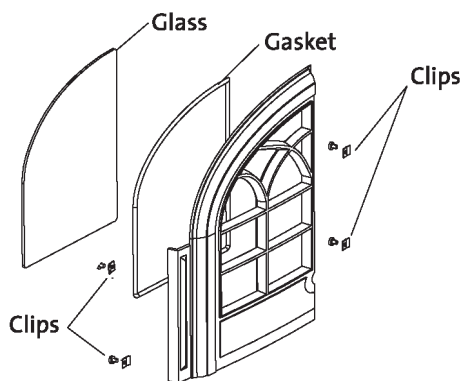
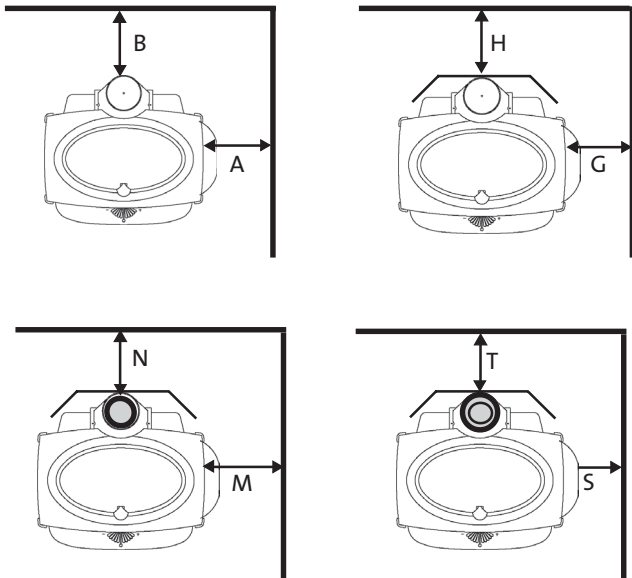

Fig.13



# Jøtul F 600 Woodstove Clearances

## Unprotected Surface Parallel to the Wall



## Protected Surface Parallel to the Wall

PER NFPA 211 or  
CAN/CSA-B365

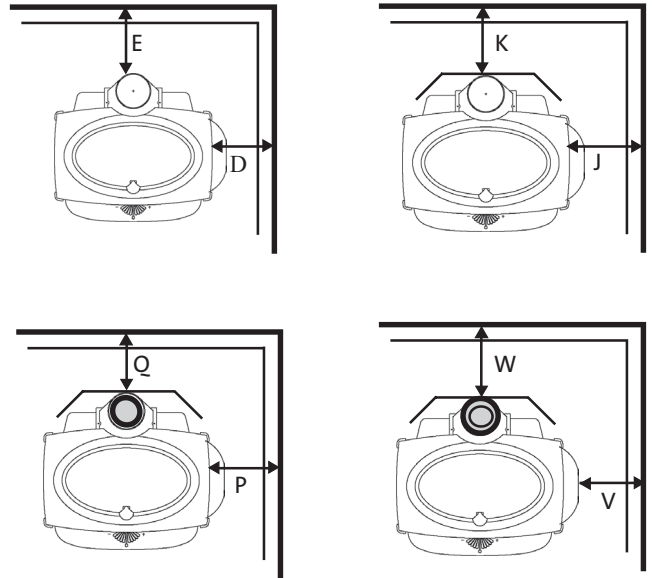

**Important:**  
Connector heatshields and double wall pipe must be a listed product.  
Always follow the manufacturer's instructions.



## Unprotected Surface Corner Installation

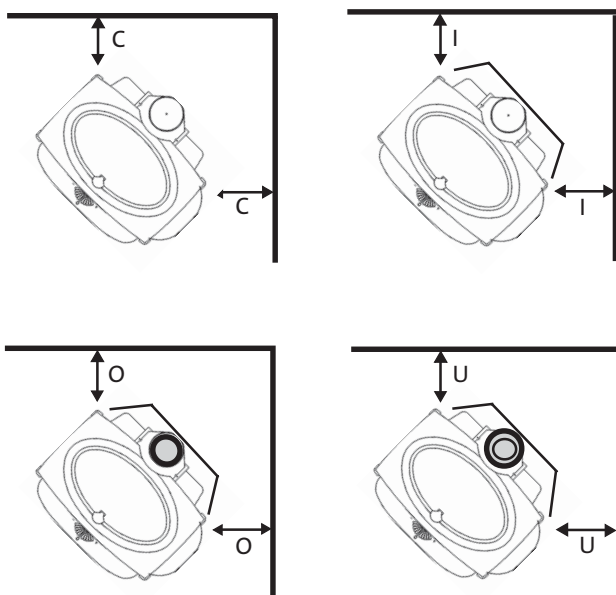

## Protected Surface Corner Installation

PER NFPA 211 or  
CAN/CSA-B365

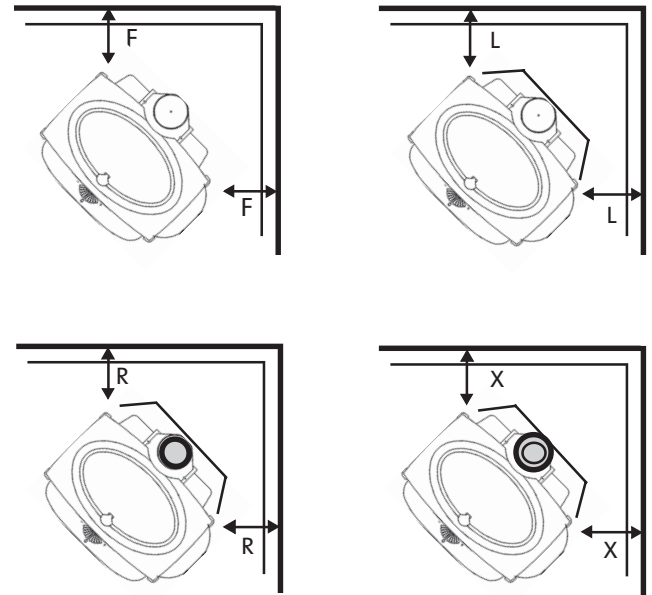

## Jøtul F 600 Woodstove Clearances

Stove clearances	Unprotected surface Parallel installation			Protected surface NFPA 211 Parallel installation		
	Side	Rear	Corner*	Side	Rear	Corner*
Stove- no heatshields Single wall pipe	13" A 330mm	19" B 480mm	13" C 330mm	6" D 150mm	12" E 300mm	9" F 230mm
Stove with rear heatshield Single wall pipe	13" G 330mm	13" H 330mm	10" I 250mm	6" J 150mm	12" K 300mm	9" L 230mm
Stove with rear heatshield With connector shield	13" M 330mm	8" N 200mm	10" O 250mm	6" P 150mm	8" Q 200mm	6" R 150mm
Stove with rear heatshield With double wall pipe	13" S 330mm	8" T 200mm	9" U 230mm	6" V 150mm	8" W 200mm	6" X 150mm

Connector clearances (pipe)	Unprotected surface Vertical installation		Protected surface NFPA 211 Vertical installation	
Single wall pipe	18" 460mm		12" 300mm	
Single wall pipe with connector shields	7" 180mm		7" 180mm	
Double wall pipe	6" 150mm		6" 150mm	

Connector clearances (pipe)	Unprotected surface Horizontal installation		Protected surface NFPA 211 Horizontal installation	
Single wall connector	18" 460mm		12" 300mm	
Double wall pipe	6" 150mm		6" 150mm	
Mantel and trim clearances	Stove to 1" thick or less, side trim		11" 280mm	
	Stove to 1" thick or less, top trim		17" 430mm	
	Stove to mantel- maximum mantel depth 11"		26" 660mm	

\* **Attention: Stove and pipe clearances must both be taken into Consideration. The greater clearance dictates the stove's position.**

\* **Use of the right side load door is prohibited in alcove and Corner installations.**

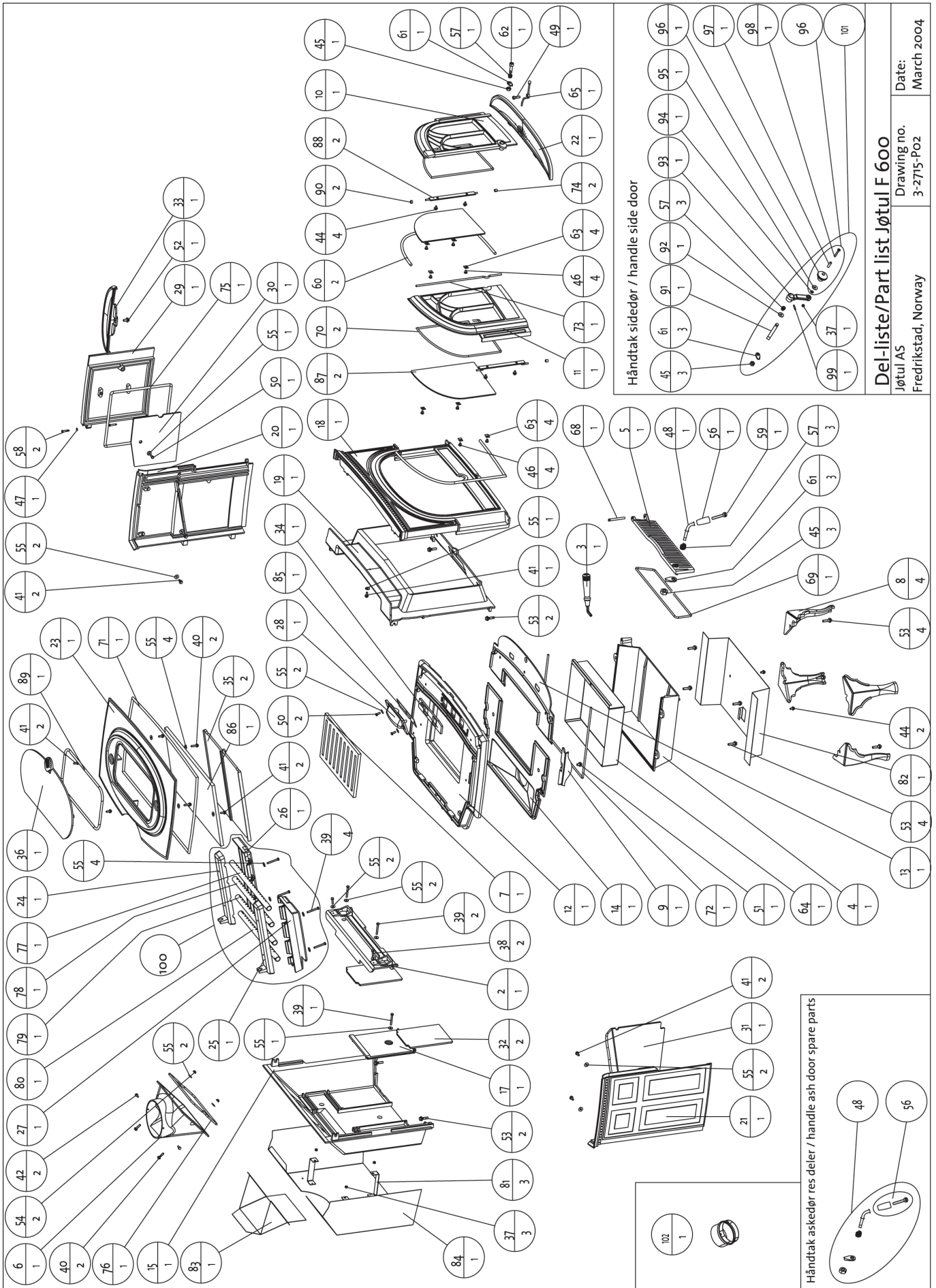

**Del-liste/Part list Jøtul F 600**

Jøtul AS Fredrikstad, Norway	Drawing no. 3-2715-P02	Date: March 2004
---------------------------------	---------------------------	---------------------

## Part list for Jøtul F 600

Pos.	no. Description	Pos.	no. Description
2	Tube Frame Holder	85	Air Restrictor
3	Handle	86	Insulation Blanket
4	Ash House Compl.	87	Glass
5	Ash Door	88	Front Door Hinge
6	Smoke Outlet	89	Gasket (Top Cover)
7	Fire Grate	90	Shaft Collar Ø6 X Ø12 X 6 mm
8	Leg	91	Latch Bolt Side Door
9	Decorative Cover Side	92	Washer
10	Door Right w/o Glass, Ver 3	93	Latch
11	Door Left w/o Glass, Ver 3	94	Washer
12	Bottom	95	Washer, Insulating
13	Inner Bottom, Front Part	96	Wooden Knob Side Door
14	Inner Bottom, Rear Part	97	Distance Sleeve for Side Door
15	Rear Plate	98	Screw Pan Head
17	Air Manifold	99	Pin
18	Front	100	Air Chamber Complete
19	Inner Front	101	Handle Side Door Complete
20	Side Right	102	Adapter Outside Air
21	Side Left		
22	Ash Lip Front		
23	Top		
24	Tube Holder Upper Right		
25	Tube Holder Upper Left		
26	Tube Holder Bottom Right		
27	Tube Holder Bottom Left		
28	Inspection Cover		
29	Side Door		
30	Burnplate Side Door		
31	Burnplate Left		
32	Burnplate Rear		
33	Ash Lip Side		
34	Air Valve		
35	Baffle Plate		
36	Top Cover		
37	Nut Stainless		
38	Screw Hexagon Stainless		
39	Screw Hexagon		
40	Screw Collar Hexagon		
41	Screw Collar Hexagon		
42	Screw Selfthread		
43	Screw Collar Hexagon		
44	Screw Collar Hexagon		
45	Nut Hexagon		
46	Screw Panh. (Front Door)		
47	Washer		
48	Latch Bolt Ash Door		
49	Screw Allen		
50	Screw Hexagon Stainless		
51	Screw Collar Hexagon		
52	Screw Collar Hexagon		
53	Screw Collar Hexagon		
54	Nut Collar Hexagon		
55	Washer		
56	Wooden Knob Ash Door		
57	Spring for Latch Bolt		
58	Hinge Pin Front/Side Door		
59	Screw Syl. Head		
60	Gasket (Door to Front)		
61	Latch		
62	Latch Bolt		
63	Glass Clip		
64	Ash Pan		
65	Handle for Air Vent		
68	Hinge Pin, Ash Door		
69	Gasket (Ash Door)		
70	Gasket (Glass)		
71	Gasket (Top)		
72	Gasket (Ash House)		
73	Gasket (Left Door Middle)		
74	Sleeve for Door Hinge		
75	Gasket (Side Door)		
76	Gasket (Smoke Outlet)		
77	Tube First From Front		
78	Tube Second From Front		
79	Tube Third From Front		
80	Tube Forth From Front		
82	Bottom Heatshield		
83	Heatshield Top Exit		
84	Rear Heatshield		

## Alternate floor protection

All floor protection materials must be non-combustible ie. metal, brick, stone, mineral fiber boards). Any combustible material may not be used.

The easiest means of determining if a proposed alternate floor material meets requirements listed in this manual is to follow this procedure.

R-value = thermal resistance  
k-value = thermal conductivity  
C-value = thermal conductance

- Convert the specification to R-value;
  - If R-value is given, no conversion is needed.
  - If k-value is given with a required thickness (T) in inches:  $R=1/k \times T$ .
  - If C-value is given:  $R=1/C$ .
- Determine the R-value of the proposed alternate floor protector.
  - Use the formula in Step 1 to convert values not expressed as "R".
  - For multiple layers, add R-values of each layer to determine overall R-value.
- If the overall R-value of the system is greater than the R-value of the specified floor protector, the alternate is acceptable.

**Example:**

The specified floor protector should be 3/4" thick material with a k-factor of 0.84. The proposed alternate is 4" brick with a C-factor of 1.25 over 1/8" mineral board with a k-factor of 0.29.

**Step A.** Use formula above to convert specifications to R-value.  $R=1/k \times T= 1/.84 \times .75 = .893$

**Step B.** Calculate R of proposed system.

$$4" \text{ brick of } C=1.25, \text{ therefore} \\ R \text{ brick} = 1/C = 1/1.25 = 0.80. \\ 1/8" \text{ mineral board of } k = 0.29 \text{ therefore} \\ R \text{ mineral board} = 1/.29 \times 0.125 = 0.431$$

$$\text{Total } R = R \text{ brick} + R \text{ mineral board} = \\ 0.8 + 0.431 = 1.231$$

**Step C.** Compare proposed system  $R = 1.231$  to specified R of 0.893. Since R is greater than required, the system is acceptable.

## Definitions:

Thermal conductance =

$$C = \frac{\text{Btu}}{(\text{hr})(\text{ft}^2)(\text{F})} = \frac{\text{W}}{(\text{m}^2)(\text{K})}$$

Thermal conductivity =

$$k = \frac{\text{Btu}}{(\text{hr})(\text{ft}^2)(\text{F})} = \frac{\text{W}}{(\text{m}^2)(\text{K})} = \frac{(\text{Btu})}{(\text{hr})(\text{ft})(\text{F})}$$

Thermal resistance =

$$R = \frac{\text{Btu}}{(\text{hr})(\text{ft}^2)(\text{F})} = \frac{(\text{m}^2)(\text{K})}{\text{W}} = \frac{(\text{Btu})(\text{inch})}{(\text{hr})(\text{ft}^2)(\text{F})}$$

**For the Jøtul F 600 woodstove requires floor protection with a minimum insulating r value of 0.5.**

**Alcoves require an r value of 1.6.**

## Innhold

### Forhold til myndighetene

Tekniske data for Jøtul F 600 .....	20
Sikkerhetsregler .....	21
Brannforebyggende tiltak .....	21

### Installasjon av Jøtul F 600

Fundamentering .....	21
Skorstein .....	21
Luftsirkulasjon .....	21
Montering før installasjon .....	21
Kontroll av funksjoner .....	21
Montering av røykrør .....	22
Tilslutning til skorstein .....	22

### Bruksanvisning

Første gangs opptenning og daglig bruk .....	22
Ved første gangs oppfyring .....	22
Daglig bruk .....	22

### Vedlikehold

Rengjøring av glass .....	23
Fjerning av aske .....	23
Rensing og sotfjerning i produktet .....	23
Feiing av røykrør til skorstein .....	23
Kontroll av ildstedet .....	23
Utvendig vedlikehold .....	23
Vedlengde-, mengde-, og kvalitet .....	23
Jøtuls definisjon av kvalitetsved .....	23

### Servicearbeider

Utskifting av brennplater .....	24
Utskifting av hvelv .....	24

### Tilleggsutstyr

Stuss for tilkobling av uteluft .....	24
---------------------------------------	----

Figurer .....	59
---------------	----

## Forhold til myndighetene

Jøtul F 600 er et rentbrennende produkt.

Typeskiltet av varmebestandig material ligger sammen med monterings- og bruksanvisningen inne i produktet. Det inneholder følgende informasjon; produsent, adresse, produktnavn, katalognummer, produksjonsnummer, effekt- og godkjenningnummer. Typeskiltet kan festes bak på U.S godkjenningsskiltet eller bak på evt.skjermplate. Denne selges separat.

**Installasjonen av et ildsted må være i henhold til det enkelte lands lover og regler. Ta alltid kontakt med din lokale bygningsinspektør eller den myndighet som bestemmer hvilke lover og regler som er i ditt område. Din forhandler har blitt spesielt utvalgt for sin kunnskap om produktet og de lokale regler og krav, og kan tilby deg hjelp for å sørge for at installasjonen er sikker og lovlig.**

Installasjonen kan først tas i bruk når den er kontrollert av kvalifisert kontrollør.

**Advarsel!** Man må forsikre seg om at det er nok ventilasjon i det rommet hvor ildstedet blir installert.

**Utilstrekkelig luft-tilførsel kan forårsake at røykgasser kommer ut i rommet. Dette er meget farlig! Symptomer på dette kan være tretthet, kvalme og uvelhet.**

Det er viktig å forsikre seg om at pipen er riktig dimensjonert for ildstedet og at pipetilslutningen er tett og fungerer korrekt. Røykgass som trenger inn i lukkede rom kan representere en alvorlig helsefare.

### Tekniske data for Jøtul F 600:

Materiale:	Støpejern
Overflatebehandling:	Sort lakk, blåsort-, sjøgrønn emalje
Type brensel:	Ved
Maks. vedlengde:	55 cm
Trekksystem:	Topp- og undertrekk
Forbrenningssystem:	Sekundærforbrenning
Røykuttak:	Topp/bak
Røykrør:	Ø 150 mm
Mulighet for stålpipeline:	Ja
Vekt ca.:	200 kg
Produktmål, avstands- mål til beskyttet/ ubeskyttet vegg:	Se fig. 1 og 2

## Sikkerhetsregler

**Krav til gulvplate:** Skal ildstedet anbringes på gulv av brennbart materiale, må hele gulvet under ildstedet, og minimum **500 mm** foran ildstedet og på høyre side av ildstedet, dekkes av en plate av ikke brennbart materiale (se mål **fig. 2**). Størrelsen av denne platen er avhengig av de stedlige lover og regler, og vi anbefaler at man kontakter den lokale Jøtulforhandler før montering.

Avstand til brannmur eller beskyttet vegg: Kontakt dine lokale bygningsmyndigheter angående restriksjoner og installasjonskrav.

Produktets sidedør skal ikke benyttes når ildstedet blir installert i en nisje eller i et hjørne.

**Uisolert røykrør:** Hvis uisolert røykrør går gjennom etasjeskiller eller vegg, skal det støpes eller mures rundt, slik at rørets ytre flate ikke kommer nærmere brennbart materiale enn **230 mm**. Isolerte røykrør kan ha en annen avstand, jfr. eventuelt brannteknisk produktdokumentasjon for røykrøret.

## Brannforebyggende tiltak

Enhver bruk av ildstedet kan representere en viss fare. Ta derfor hensyn til følgende anvisninger:

- Skal produktet anvendes med åpen dør, må alltid gnistfanger brukes.
- Sørg for at møbler og annet brennbart materiale ikke kommer for nær ildstedet. Det bør være en avstand foran ildstedet på minst **800 mm**.
- La ilden brenne ut. Slukk den aldri med vann da dette kan skade produktet.
- Ildstedet blir varmt under fyring, og kan forårsake forbrenning hvis det berøres.
- Aske må plasseres forsvarlig utendørs, eller tømmes der dette ikke medfører brannfare.
- Til ethvert ildsted bør det være en oppbevaringsbeholder av ikke-brennbart materiale med lokk for sot og aske. Sot og aske må oppbevares i denne beholderen minst 1 uke, for å være sikker på at siste gnist er slukket. Må beholderen tømmes før den tid, skal rikelig med vann slås i beholderen og røres om.
- Ta gjerne vare på asken. Den er utmerket i bruk som gjødsel til f.eks. roser.

## Installasjon av Jøtul F 600

**NB! Kontroller at ildstedet er fri for skader før installasjonen begynner.**

**Produktet er tungt! Sørg for hjelp når det skal settes opp og monteres.**

### Fundamentering

Dersom Jøtul F 600 skal plasseres på et tregulv, bør man forsikre seg om at gulvet under ildstedet er dimensjonert for dette.

### Skorstein

Ildstedet kan tilknyttes teglstensskorstein, elementskorstein eller Jøtul stålskorstein. Se eget avsnitt. Minimum skorsteinstverrsnitt må være **177 cm<sup>2</sup>** (tilsvarende  $\varnothing 150$  mm). Tilslutning til skorstein må utføres i henhold til skorsteinsleverandørenes monteringsanvisninger.

### Luftsirkulasjon

Bruk av ildsted krever rikelig frisklufttilgang til rommet der produktet er plassert. Dersom huset er tett, bør rommet utstyres med ekstra frisklufttilførsel gjennom ventiler. Mekanisk avtrekk bør ikke brukes i et rom med ildsted. Dette kan skape undertrykk og kan trekke giftige gasser inn i rommet. For å unngå dette er det mulig å ta inn luft utenfra direkte til ildstedet ved hjelp av et adapter (tilleggsdel) som festes til luftinntaket på ildstedet. En fleksibel slange føres derfra og ut av huset. Monteringsanvisningen til dette følger installasjonsenheten.

### Montering før installasjon

Produktet leveres i ett kolli. Det medfølger også et løst håndtak for betjening av dør. Den ovale topplaten er skrudd fast under transporten. Skru ut skruene fra undersiden av topplaten, og la denne ligge løst. På den måten er det enklere for feieren når produktet og røykrøret skal rengjøres.

Askeleppene, som ligger festet på toppen, løsnes, og legges på plass. Den forreste legges løst oppe på bunnplaten, mens sideaskeleppen festes med skruen som er skrudd fast i bunnplaten.

### Kontroll av funksjoner (fig. 3)

Kontroller alltid betjeningsorganene når produktet er oppstilt. Disse skal bevege seg lett, og virke tilfredsstillende.

#### Trekkventil (A)

Venstre posisjon = lukket. Høyre posisjon = fullt åpnet.

#### Dørhåndtak (B)

Mot venstre = åpnet. Mot høyre = lukket.

#### Dørhåndtak (C)

Mot høyre = åpnet. Mot venstre = lukket.

# NORSK

## Askedør (E)

Åpne døren ved å dreie håndtaket en halv omdreining mot klokken. Bruk en hanske e.l. og trekk skuffen ut.

**NB!** Fjern asken kun når ildstedet er kaldt.

## Montering av røykrør

Ildstedet bør prøvemonteres først uten at det tas hull i skorsteinen. Se **fig. 2** for mål til vegg av brennbart materiale. Ildstedet monteres med Ø150 mm røykrør. Dette skal være av godkjent tykkelse.

**Røykuttaket til Jøtul F 600 ligger under transporten inne i brennkammeret. Det er valgfritt om man vil ha topp- eller bakuttak av røykrøret. Skruene til å feste med ligger i skruerosen.**

- Røykrør Ø 150 mm plasseres direkte inn på produktets røykuttak. På begge sider av produktets røykuttak er det plassert en skrue (**fig. 4-A**). Disse skal brukes til å feste røykrøret.
- Merk av på røykrøret hvor skruene treffer når røret er helt i bunnen av røykuttaket, og bor et hull på 5,5 mm i røykrøret for skruen.
- Bruk pakningssnor og kitt til å tette mellom røykrør og produktets røykuttak. Plasser pakningssnoren rundt nederste del av røykrøret og fyll opp mellomrommet med kitt.
- Skru fast røykrøret.

**NB!** Det er viktig at sammenføyningene er helt tette. Falsk luft e.l. kan ødelegge funksjonen.

## Tilslutning til skorstein

Bor hull for røykrøret. Avstand fra ovn til brannmur/ skorstein skal være som vist i **fig. 2**. Bruk alltid murstuss ved montering på skorstein. På element skorsteinene skal leverandørens anbefalte murstuss brukes. Følg nøye leverandørens monterings- og bruksanvisning ved tilslutning til skorstein med hensyn til tørketid av mørtel/ ovnskitt, før ildstedet tas i bruk.

Se til at røykrøret aldri heller inn mot skorsteinen. Det skal minimum være vannrett, aller helst ha noen millimeters stigning.

**NB!** En korrekt og tett tilslutning er meget viktig for produktets funksjon.

Vær obs på at det er særdeles viktig at tilslutninger har en viss fleksibilitet. Dette for å forhindre at setninger i huset fører til sprekkdannelser.

# Bruksanvisning

## Første gangs opptenning og daglig bruk

Jøtul F 600 er et rentbrennende produkt som ved hjelp av ekstra tilførsel av forbrenningsluft, sørger for en etterbrenning av skadelige gasser og partikler. Det er viktig at systemet blir brukt riktig.

Ildstedet er utstyrt med betjeningsmuligheter som er beskrevet i avsnittet: Kontroll av funksjoner.

## Ved første gangs oppfyring

Åpne trekkventilen på døren fullt ved å skyve ventilen helt til høyre (**fig. 3-A**). Legg i avispapir, fliser og ved, og begynn med et lite bål. Øk mengden etter hvert og fyr friskt et par timers tid. La det brenne ut og gjenta så dette en gang til.

### **NB!** Lukt under innfyring:

*Lakkerte produkter:* Under første gangs oppfyring kan ildstedet gi fra seg en irriterende gass som kan lukte noe. Gassen er ikke giftig, men det bør foretas en skikkelig utlufting av rommet. Fyr med god trekk til samtlige gasser har brent ut - til hverken røyk eller lukt merkes mer.

*Emaljerte produkter:* De første gangene et nytt ildsted brukes, kan det danne seg kondensvann på overflaten. Dette må tørkes bort for å unngå at det dannes varige flekker når overflaten blir varm.

## Daglig bruk

Tenn opp ved hjelp av avispapir og noe finkløyvd ved. Legg to halvstore trestykker ut/inn på hver sin side i peisbunnen. Krøll litt avispapir (evt. never fra bjørkeved) mellom disse, legg litt finkløyvd ved på kryss og tvers, og tenn opp. Øk vedstørrelsen etter hvert.

**Trekkventilen (fig. 3-A)** reguleres når veden har antent skikkelig og brenner godt. Kontroller at etterbrenning (sekundærforbrenning) starter. Dette sees best ved å kontrollere at gule stikkflammer brenner ved hvelvet. Deretter regulerer du forbrenningen til ønsket varmeavgivelse ved hjelp av trekkventilen.

Bruk *alltid* kvalitetsved. Det gir det beste resultatet, og vil ikke påføre produktet skader.

### **Fyr aldri med følgende materialer:**

- husholdningsavfall, plastposer o.l.
- malt eller impregnert trevirke (som er meget giftig)
- spon- og laminerte plater
- rekved (drivved)

*Dette kan skade produktet, og er forurensende.*

**NB!** Bruk aldri væsker som bensin, parafin, rødsprit e.l. til opptenning. Du kan skade både deg selv og produktet.

**NB! Advarsel mot overfyring: Ildstedet må aldri overfyres.** Med overfyring forstås et for stort ilegg av ved, og/eller ikke regulert trekk.

*Trekken i skorsteinen bør ikke overstige 2,5 mmVs (25 Pa).*

Et sikkert tegn på overfyring er at produktet får glødende punkter. Reduser da trekkinnstillingen øyeblikkelig.

**OBS! Hvert ilegg bør brenne ned til glør før du på nytt legger i.**

## Vedlikehold

### Rengjøring av glass

Jøtul F 600 er utstyrt med topptrekk (luftspyling). Ved hjelp av trekkventilen suges det luft inn i overkant av ildstedet og spyles nedover langs innsiden av glasset. Dette systemet har den fordel at det gir bedre forbrenning og reduserer sotbelegget på glasset.

Det vil allikevel alltid dannes noe sot på glasset, men mengden vil være avhengig av de stedlige trekkforhold og regulering av trekkventilen. Mesteparten av sotbelegget vil normalt bli brent av når trekkventilen blir regulert opp til maks., og det fyres friskt i ildstedet.

**Et godt råd!** Ved vanlig rengjøring; fukt et kjøkkenpapir med varmt vann og ta på litt aske fra brennkammeret. Gni over glasset og tørk deretter av glasset med rent vann.

### Fjerning av aske

Jøtul F 600 har askeskuff som gjør det enkelt å fjerne asken. Skrap asken gjennom risten i fyrbunnen og ned i askeskuffen. Bruk en hanske eller det løse håndtaket. Ta tak i håndtaket til askeskuffen og bær asken ut. Se til at askeskuffen aldri blir så full at det hindrer asken i å komme gjennom fyrriksen og ned i skuffen.

**Sørg for at døren til askeskuffen er godt stengt under fyring i ildstedet.**

Det er alltid en fordel om noe aske blir liggende igjen inne i brennkammeret som et beskyttende lag mot ildstedbunnen. Se forøvrig beskrivelse av hvordan håndtere aske under: **Brannforebyggende tiltak.**

### Rensing og sotfjerning i produktet

Under fyring vil det kunne danne seg et sotbelegg på innsiden av ildstedets varmeplater. Sot har en god isolerende effekt, og vil derfor redusere ildstedets varmeavgivelse.

En årlig rengjøring innvendig vil være nødvendig for å få maksimalt varmeutbytte av produktet. Foreta dette gjerne i forbindelse med feiing av skorstein og piperør.

### Feiing av røykrør til skorstein

Feiing av røykrør kan utføres gjennom å løfte vekk den løse ovale topplaten. Det er da enkelt å komme til for feiing. Evt. kan det feies gjennom en feieluke i røykrøret, eller gjennom produktets døråpning. Da må hvelvet først fjernes. Se egne avsnitt under: Servicearbeider.

### Kontroll av ildstedet

Jøtul anbefaler at du selv kontrollerer ditt ildsted nøye etter at feiing/rengjøring er gjennomført. Kontroller alle synlige overflater for sprekker. Se også til at alle sammenføyninger er tette, og at pakninger ligger riktig. Pakninger som er slitte eller deformerte, bør byttes ut.

Rens pakningssporet godt, påfør keramisk lim (fås kjøpt hos din lokale Jøtul forhandler), og press pakningen godt på plass. Etter kort tid er sammenføyningen tørr.

### Utvendig vedlikehold

*Lakkerte produkter* vil etter noen års bruk kunne endre farge. Overflaten bør pusses og børstes fri for løse partikler før ny Jøtul ovnslakk påføres.

*Emaljerte produkter* skal kun tørkes med en tørr klut. Bruk ikke vann og såpe. Eventuelle flekker fjernes med et rensmiddel (Stekeovnsrens e.l.).

### Vedlengde, -mengde, og -kvalitet

Maks. vedlengde er **55 cm**. Veden legges parallelt med brennkammerets bakvegg. Jøtul F 600 har med sin virkningsgrad en varmeavgivelse på **minimum 3,5 kW** og **nominell ca 10,0 kW**. Etter beregninger tilsvarer nominell varmeavgivelse forbruk av ca. 4,0 kg kvalitetsved pr. time.

### Jøtuls definisjon av kvalitetsved

**God kvalitetsved bør være tørket slik at vanninnholdet er på ca. 20-25%.**

For å oppnå dette, bør veden hugges senest på ettervinteren. Den kløyves og stables på en slik måte at den blir luftet. Stablene må overdekkes for ikke å trekke for store mengder regnvann. Veden bør tas inn tidlig høst, og stables/lagres for bruk kommende vinter.

Med kvalitetsved menes det meste av kjent norsk trevirke, som bjørk, gran og furu.

# NORSK

Energimengde i 1 kg ved varierer lite. På den annen side varierer egenvekten hos de ulike typene ved relativt mye. Dette innebærer at energimengden (kWh) i en bestemt volummengde, f.eks. gran, er mindre enn for den samme volummengde av eik som har høyere egenvekt.

Energimengden til 1 kg kvalitetsved er ca. 3,8 kWh. 1 kg helt tørr ved (0 % fuktighet) gir ca 5 kWh, mens ved med en fuktighetsgrad på 60%, bare gir ca 1,5 kWh/kg.

## Servicearbeider

### Utskifting av brennplater

- Ildstedet har brennplater i sider, og bak. Brennplaten som er på den høyre døren er festet med en skrue.
- Ved utskifting løsnes skruen og brennplatene fjernes.
- Ved tilbakemontering følges samme prosedyre.

### Utskifting av hvelv

- Hvelvet, som består av 2 støpejernsplater, hviler oppe på rørene som gir tilførsel av sekundærluft.
- Ved demontering løftes disse litt opp i midten og tas ut.
- Ved montering legges begge på plass på samme måte. Se til at disse blir plassert tett mot bakveggen.
- Legg så tilbake isolasjonsmatten på toppen av hvelvplatene.

## Tilleggsutstyr

### Stuss for tilkobling av uteluft - kat.nr. 221032

Til produktet kan man ved hjelp av stuss for uteluft og fleksibel slange koble til forbrenningsluft direkte utenfra. På den måten vil ildstedet alltid få den luften som er nødvendig for å oppnå riktig forbrenning.

## Table of Contents

### Relationship to the authorities

Technical data of Jøtul F 600 .....	25
General safety precautions .....	26
Measures to prevent fire danger .....	26

### Installation of Jøtul F 600

Foundations .....	26
Chimney .....	26
Air circulation .....	26
Assembly prior to installation .....	26
Control of functions .....	26
Mounting of flue pipe .....	27
Connection to chimney .....	27

### Operating instructions

Initial lighting and daily use .....	27
Initial lighting .....	27
Daily use .....	27

### Maintenance

Cleaning the glass .....	28
Ash removal .....	28
Cleaning and soot removal .....	28
Sweeping of flue pipes to the chimney .....	28
Control of the stove .....	28
External maintenance .....	28
The length, quantity and quality of logs .....	28
Jøtul's definition of quality wood .....	28

### Service

Changing the burn plates .....	29
Changing the baffle plate .....	29

### Optional equipment

Connecting pipe for outdoor ventilation .....	29
-----------------------------------------------	----

Figures - drawings .....	59
--------------------------	----

## Relationship to the authorities

Jøtul F 600 is a clean-burning product.

The product data plate is located on the heat shield and is made of heat-resistant material. The following information is listed on the data plate: Manufacturer and address, model number, manufacturing number, rated heat output, registration number (after assignment), style, and safety measurements. The plate can be fastened at the back of the U.S. rating plate or at the back of the heat shield.

Installation of a fireplace must be according to local codes and regulations in each country. Always contact your local building inspector or the appropriate authority responsible for local codes and regulations in your district. Your dealer has been specially selected for his knowledge of your local codes and may provide assistance in ensuring that your installation is safe and legal.

**Warning!** Please ensure that there is adequate ventilation in the room in which the stove is to be installed. Using a fireplace requires a plentiful supply of fresh air to the room where the product is installed. If the house is sealed, the room ought to be equipped with extra fresh air supply through vents. Avoid using mechanical fan vents in a room with a fireplace. This may cause negative pressure and draw poisonous gases into the room.

**NB! This can lead to drowsiness, nausea and sickness and is extremely dangerous.**

Instructions for mounting, installation and use are enclosed with the product. The installation may only be used when it has been inspected by a qualified controller.

### Technical data of Jøtul F 600:

Material:	Cast iron
Finish:	Black paint, blue-black and ocean green enamel
Fuel:	Wood
Log length, max.:	55 cm
Draught system:	Top and bottom draught
Combustion system:	Secondary combustion
Flue outlet:	Top/rear
Flue dimension:	150 mm dia.
Can steel pipe be fitted:	Yes
Approx. weight:	200 kg
Product measures, distance measures to protected/unprotected wall:	See <b>fig. 1 and 2.</b>

# ENGLISH

## General safety precautions

Requirements for the floor plate: If the stove is to be installed on a floor made of a flammable material, the whole floor underneath the stove, and at least 500 mm in front of the stove and to the right of the stove, must be covered by a plate made of a non-flammable material (see measures fig. 2). The size of the plate depends on the local codes and regulations, and we recommend that you contact the local Jøtul dealer prior to installation.

Distance to firewall or protected wall: Contact your local building authorities regarding restrictions and installation requirements.

The product side door should not be used when the stove is installed in a recess or corner.

**Uninsulated flue pipe:** If uninsulated flue pipes go through floors or walls, require that the opening must be made of brick or masonry, in such a way that the external surface of the pipe does not get closer than **230 mm** to any flammable materials. Isolated flue pipes may have a different distance, if necessary refer to fire technical product documentation for the flue pipe.

## Measures to prevent fire danger

**Any use of the fireplace may represent some danger.** Therefore, respect the following instructions:

- Always use a spark catcher if the product is to be utilised with an open door.
- Ensure that furniture and other flammable materials do not get too close to the fireplace. There ought to be a safe distance from the front of the fireplace to flammable material. Check your local codes and regulations.
- Let the fire die. Never put it out with water as this may damage the product.
- The fireplace gets hot when used and may cause burns if touched.
- Ash must be properly disposed of outdoors, or emptied where it does not entail a fire hazard. Refer to local regulations.
- Any stove should have a storage container made of non-flammable material as a standard accessory for the safe disposal of soot and ashes. Soot and ashes must be stored in this container for at least a week in order to be certain that the last ember has been extinguished. If the container needs to be emptied before this, add plenty of water to the container and stir.
- You may want to keep the ash. It is a first class fertilizer for roses and other plants.

## Installation of Jøtul F 600

**Note! Check that the stove is free of any damage prior to commencing installation.**

**The product is heavy! Make sure you have assistance when erecting and installing it.**

### Foundations

If Jøtul F 600 is to be installed on a wooden structure, ensure that the floor under the stove has the proper support to carry the stove.

### Chimney

The stove can be connected to a brick, pre-fabricated element or Jøtul steel chimney. **See separate section.** Minimum chimney cross section must be 177 cm<sup>2</sup>. (Corresponding to 150 mm dia.). Connection to chimney must be done in accordance with the installation instructions from the supplier of the chimney.

### Air circulation

Using a fireplace requires a plentiful supply of fresh air to the room where the product is installed. If the house is sealed, the room ought to be equipped with extra fresh air supply through vents. Avoid using mechanical fan vents in a room with a fireplace. This may cause negative pressure and draw poisonous gases into the room.

In order to avoid this, it is possible to bring in outside air directly to the stove by using an adapter (extra unit) that is mounted to the air inlet of the stove. From there a flexible hose is conducted out of the house. The installation instruction for this is enclosed with the installation unit.

### Assembly prior to installation

The product is delivered in one package. A loose handle for the door is also included. The oval top plate is fastened with screws during transport. Remove the screws from underneath the top plate and leave it unattached. This makes it easier for the chimney sweep when the product and the flue pipe have to be cleaned.

Undo the ash lips, which are fastened to the top, and install. The one in front is placed loosely on top of the base plate, while the side ash lip is fastened with the screw that is attached to the base plate.

### Control of functions (fig. 3)

When the product is set up, always check the control functions. These shall move easily and function satisfactorily.

**Draught vent (A)**

Left position = closed.

Right position = fully open.

**Doorhandle (B)**

Towards the left = open. Towards the right = closed.

**Doorhandle (C)**

Towards the right = open. Towards the left = closed.

**Ash door (E)**

Open the door by turning the handle counter-clockwise one half rotation. Use a glove or similar and pull out the tray.

**Note! Only remove the ashes when the stove is cold**

## Mounting of flue pipe

It is advisable to carry out a test assembly prior to making a hole in the chimney. See **fig. 2** for measures to wall made of flammable materials. The stove is installed with a 150 mm diameter flue pipe. This must be an approved thickness. The flue outlet for Jøtul F 600 is inside the burn chamber during transportation. You can choose between a top or rear outlet from the flue pipe. The screws for fastening are in the bag containing screws.

- Flue pipes 150 mm dia. are placed directly onto the product flue outlet. There is a screw on both sides of the product flue outlet (**fig. 4-A**). These are used to fasten the flue pipe.
- Mark where the screws hit the flue pipe when it is at the very bottom of the flue outlet and drill a 5,5 mm hole for the screw in the flue pipe.
- Use gasket and cement to seal between flue pipe and product flue outlet. Place the gasket around the lower part of the flue pipe and fill up the space with cement.
- Fasten the flue pipe with screws.

**Note! It is important that the joints are completely sealed. Air leakage etc. may lead to malfunction.**

## Connection to chimney

Drill a hole for the flue pipe. Distance from stove to firewall/ chimney should be as shown in **fig. 2**. Always use a chimney collar when connecting to chimney. Use the supplier's recommended chimney collar when connecting to an element chimney. Follow the supplier's assembly and usage instructions closely with regard to mortar/furnace cement before starting to use the fireplace.

Ensure that the flue pipe never slopes down towards the chimney. It should at least be horizontal, preferably have an incline of a few millimeters.

**Note! A correct and sealed connection is very important for the proper functioning of the product.**

Be alert to the fact that it is particularly important that connections have a certain flexibility. This is to prevent setting of the house from leading to fissuration.

# Operating instructions

## Initial lighting and daily use

Jøtul F 600 is a clean-burning product and with additional supplies of combustion air, it allows for afterburning of hazardous gases and particles. It is important that the system is used correctly.

The stove is equipped with certain functions that are described in the chapter: Control of functions.

## Initial lighting

Open the draught vent fully by pushing the vent all the way to the right (**fig. 3-A**). Put in some crumpled newspaper, kindling wood and firewood and start a small fire. Add more firewood gradually and let the fire burn briskly for a couple of hours. Let the fire die out and repeat one more time.

### **Note! Odors when using the stove for the first time.**

*Painted products.* The stove may emit an irritating gas when used for the first time, and it may smell a little. The gas is not toxic, but it is recommended to open a window or a door to provide additional ventilation in the room. Let the fire burn with a high draught until all traces of gas have disappeared and no smoke or smells can be detected.

*Enamelled products:* Condensation may form on the surface of the stove the first few times it is used. This must be wiped off to prevent permanent stains forming when the surface heats up.

## Daily use

Fire up with the aid of newspapers and some kindling wood. Place two medium sized logs in/out on each side of the base. Crumple some newspaper (or birch bark) between these and add some kindling wood in a criss-cross pattern on top and light the newspaper. Increase the size of the logs gradually.

Draught vent (**fig. 3-A**). Regulate when the wood is properly lit and burns well. Check that the afterburning (secondary combustion) starts. This is best indicated by yellow, flickering flames in the air chamber. Then regulate the rate of combustion to the desired level of heating by adjusting the draught vent.

*Always use good quality firewood. It gives the best results and does not damage the product.*

### **Never burn the following materials in the stove:**

- household waste, plastic bags etc.
- painted or impregnated wood (highly toxic)
- chipboard or laminated boards
- driftwood

*This may harm the product and pollute the atmosphere.*

# ENGLISH

**Note! Never use flammable liquids such as petrol, kerosene, red spirit or similar to start the fire. This may cause harm to both yourself and the product.**

**Note! Danger of overheating: The stove must never be used in a manner that causes overheating.**

Overheating is defined as overfilling the stove with firewood and/or leaving the draught vent fully open.

*The chimney draught should never exceed 2,5 mmVs (25 Pa).* A sure sign of overheating is when parts of the stove glows red. When this happens, reduce the draught vent opening immediately. (Move draught vent to the left).

**Warning! Each fire should burn down to embers before new firewood is added.**

## Maintenance

### Cleaning the glass

Jøtul F 600 is equipped with top draught (air wash). Through the draught vent air is sucked in above the fireplace and washed down along the inside of the glass. This system has the advantage that it provides better combustion and reduces the buildup of soot deposits on the glass.

Still, some soot will always stick to the glass, but the quantity will depend on the local draught conditions and adjustment of the draught vent. Most of the soot layer will normally be burned off when the draught vent is opened all the way and a fire is burning briskly in the fireplace.

Good advice! For normal cleaning, moisten a paper towel with warm water and add some ash from the burn chamber. Rub it over the glass and then clean the glass with clean water.

### Ash removal

Jøtul F 600 has an ash pan, which makes it easy to remove the ash. Scrape the ash through the grate in the base plate and into the ash pan. Use a glove or the loose handle, take hold of the handle on the ash pan and take away the ash. Make sure that the ash pan doesn't fill up so high that it keeps ash from coming through the grate into the pan.

*Make sure the door to the ash pan is securely shut when the stove is in use.*

Also see the description of how to handle ashes under Measures to prevent fires.

### Cleaning and soot removal

Soot deposits may build up on the internal surfaces of the stove during use. Soot is a good insulator and will therefore reduce the stove's heat output.

An annual internal cleaning is necessary to get the best heating effect from the product. It is a good idea to do this in connection with the sweeping of the chimney and flue pipes.

### Sweeping of flue pipes to the chimney

Sweeping of the flue pipes is carried out by lifting the loose oval top plate. This gives easy access for sweeping. It is possible to sweep through the sweeping hatch in the flue pipe or through the product door opening. In that case the baffle plate has to be removed first. See appropriate sections under: **Service**.

### Control of the stove

Jøtul recommends that you personally control your stove carefully after sweeping/cleaning. Check all visible surface areas for cracks. Also check that all joints are sealed and that the gaskets are in the correct position. Any gaskets showing signs of wear or deformation must be replaced.

Thoroughly clean the gasket grooves, apply ceramic glue (available from your local Jøtul dealer), and press the gasket well into place. The joint will dry quickly.

### External maintenance

*Painted products* may change color after several years usage. The surface should be cleaned and brushed free of any loose particles before new Jøtul stove paint is applied. Enamelled products must only be cleaned with a clean, dry cloth. Do not use water and soap. Any stains can be removed with a cleaning fluid (Oven cleaner etc.).

### The length, quantity and quality of logs

The maximum length of logs to be used is **55 cm**. Logs should be placed parallel to the back wall of the combustion chamber. **Minimum heat emission** from Jøtul F 600 is **ca 3.5 kWh**, and **the nominal capacity 10 kWh**. The calculated requirement for nominal heat emission is approx. 4,0 quality wood per hour.

### Jøtul's definition of quality wood

**Good quality wood should be dried so that the water content is approx. 20-25%.**

To achieve this, the wood should be cut during late winter or early spring. It should then be cut and stacked to ensure proper airing. The stacks should be covered to prevent them from absorbing too much rainwater. The logs should be taken indoors in autumn for use during the winter season.

With good quality firewood we mean logs from trees, such as birch, beech and oak.

The amount of energy obtainable from 1 kg of wood varies very little. On the other hand, the specific weight of the different kinds of wood varies considerably. As an example, a certain volume of birch will provide less kWh than the same volume of oak, which has a higher specific weight.

The amount of energy in 1 kg quality wood is approx. 3,8 kWh. 1 kg of completely dry wood (0 % humidity) produces approximately 5 kWh, while wood with a humidity level of 60% produces only around 1.5 kWh/kg.

## Service

### Changing the burn plates

- The stove has burn plates on the sides and in the back. The burn plate on the right door is fastened with a screw.
- To remove, unfasten the screw and remove the burn plates.
- To install, follow the same procedure.

### Changing the baffle plate

- The baffle plate consists of 2 cast iron plates and rests on top of the pipes that supply secondary air.
- To remove, lift a little upwards in the middle and take them out.
- To install, replace both plates in the same manner. Make sure they are fitted closely against the back wall.
- Then place the insulating blanket on top of the baffle plates.

## Optional equipment

### Connecting pipe for outdoor ventilation - Cat. No. 221032

With the aid of a connecting pipe for outdoor ventilation and a flexible tube, combustion air can be connected to the product directly from the outside. In this manner, the fireplace will always be supplied with the air needed to achieve proper combustion.

# FRANCAIS

## Sommaire

### Reglementations nationales

Fiche technique du modèle Jøtul F 600 .....	30
Consignes générales de sécurité .....	31
Mesures de prévention des incendies .....	31

### Installation du poêle Jøtul F 600

Soubassement .....	31
Cheminée .....	31
Circulation d'air .....	31
Montage avant l'installation .....	31
Pièces fonctionnelles .....	31
Montage du conduit de raccordement .....	32
Raccordement à la cheminée .....	32

### Consignes de fonctionnement

Mise en service et usage courant .....	32
Mise en service .....	32
Usage courant .....	32

### Entretien

Nettoyage de la vitre .....	33
Retrait des cendres .....	33
Nettoyage et élimination de la suie .....	33
Nettoyage des conduits de raccordement menant à la cheminée .....	34
Contrôle du poêle .....	34
Entretien extérieur .....	34
Longueur, quantité et qualité des bûches .....	34
Qualité du bois selon Jøtul .....	34

### Revision

Changement des plaques de doublage .....	34
Changement du déflecteur .....	34

### Équipements optionnels

Branchement du conduit de ventilation externe .....	34
-----------------------------------------------------	----

Figures-schemas .....	59
-----------------------	----

## Réglementations nationales

Jøtul est un appareil à combustion non polluante.

La plaquette de caractéristiques du produit est livrée avec le manuel d'installation et d'utilisation, elle est constituée d'un matériau résistant à la chaleur. Les informations suivantes figurent sur cette plaquette de caractéristiques: Fabricant et adresse, numéro de modèle, numéro de fabrication, puissance calorifique nominale, numéro d'enregistrement (après affectation), référence des normes françaises. La fiche signalétique peut être fixée au dos de l'étiquette d'homologation américaine ou au dos d'une plaque de convection. (La plaque de convection est vendue séparément).

### Fiche technique du modèle Jøtul F 600

Matériau :	Fonte
Traitement de surface :	Peinture noire. Email bleu noir, ou vert océan
Combustible :	Bois exclusivement
Longueur maximale des bûches :	55 cm
Système d'entrée d'air :	Par le haut
Système de combustion :	Double combustion
Raccordement :	Par le haut ou par l'arrière
Dimension du tuyau :	Ø150 mm
Poids :	200 kg
Dimensions du produit et distance par rapport à la paroi murale protégée/non protégée:	Voir les figures 1 et 2.

**Le présent manuel doit être lu entièrement avant l'installation du poêle et conservé pendant toute la durée de son utilisation.**

**L'installation des poêles doit être effectuée conformément aux normes et réglementations nationales en vigueur. Nous vous recommandons de vous inspirer des règles du D.T.U. 24.2.2. Votre revendeur ayant été spécialement sélectionné en fonction de ses connaissances de vos législations nationales, il est tout à fait à même de vous aider à adapter votre installation aux normes de sécurité et à la législation en vigueur dans votre pays.**

**Attention !** Assurez-vous que la pièce dans laquelle le poêle doit être installé est correctement ventilée.

**Une ventilation insuffisante entraîne une baisse du taux d'oxygène dans la pièce.** Cela risque de provoquer un état de somnolence, des nausées et des malaises chez les personnes présentes.

Assurez-vous que les dimensions de la cheminée sont adaptées au poêle et que le système de fixation est étanche et en bon état de fonctionnement. La présence de fumée dans un espace clos nuit gravement à la santé.

Les consignes de montage, d'installation et d'utilisation sont livrées avec le produit. L'installation doit être effectuée uniquement après l'examen d'un contrôleur qualifié.

## Consignes générales de sécurité

**Exigences relatives à l'écran protecteur au sol :** Si le poêle est destiné à être installé sur un sol constitué de matériaux inflammables, la zone située sous et devant le poêle (jusqu'à 500 mm environ) doit être recouverte d'un écran protecteur composé d'un matériau ininflammable (voir les dimensions au **schéma 2**). Votre distributeur Jøtul peut vous en fournir un à la couleur de votre appareil.

**Distance entre le poêle et un mur constitué de matériaux inflammables :** Le poêle a été testé aux distances de sécurité indiquées aux **fig. 2. Installation interdite en France**.

La porte latérale du produit ne doit pas être utilisée lorsque le poêle est installé dans une enceinte fermée ou un angle de pièce.

Si le produit doit être utilisé dans une enceinte fermée, une plaque de convection doit être installée.

## Mesures de prévention des incendies

L'utilisation d'un appareil de chauffage au bois présente toujours certains risques. Veillez donc à observer les consignes de sécurité suivantes :

- Utilisez toujours un pare-étincelles si le produit doit être utilisé portes ouvertes.
- Assurez-vous qu'aucun meuble ou matériau inflammable n'est situé trop près du poêle. Le poêle doit disposer devant lui d'une zone dégagée de **800 mm** au moins.
- Ne mouillez jamais un feu. Ne versez jamais d'eau dans votre poêle au risque de l'endommager.
- Lorsque le poêle est en service, il devient chaud et, de ce fait, risque de brûler quiconque le touche.
- Vous pouvez également conserver les cendres. Elles constituent un engrais de très bonne qualité pour les roses et autres plantes.

## Installation du poêle

**Attention ! Vérifiez que le poêle est en bon état avant d'entamer l'installation.**

**L'appareil est lourd. Veillez à vous procurer toute l'aide nécessaire avant de le monter et de l'installer.**

### Soubassement

Si votre poêle Jøtul F 600 doit être installé sur un parquet, assurez-vous que celui-ci est suffisamment solide et résistant pour en supporter le poids.

### Cheminée

Le poêle peut être raccordé à une cheminée de briques, La cheminée doit présenter une section minimale de 177 cm<sup>2</sup> (soit un diamètre de 150 mm).

Nous vous recommandons de vous inspirer des règles du **D.T.U. 24.2.2**.

### Circulation d'air

L'utilisation d'une cheminée dans une pièce suppose que celle-ci soit correctement ventilée. Si le logement d'habitation est parfaitement étanche, la pièce doit être équipée d'un dispositif supplémentaire de ventilation (bouches d'aération). Évitez d'employer des extracteurs d'air dans une pièce comportant une cheminée. Une telle installation génère une forte dépression et dissémine les gaz toxiques dans la pièce.

### Montage avant l'installation

L'appareil est livré dans un seul emballage. Ce dernier contient notamment une poignée amovible destinée à manipuler le porte.

La plaque supérieure ovale est immobilisée à l'aide de vis pendant le transport. Retirez les vis par-dessous la plaque supérieure et laissez-la détachée. Cela facilite le ramonage de la cheminée lorsque le produit et le conduit de raccordement doivent être nettoyés.

Déposer les bavettes, qui sont fixées au cadre bois supérieur, et les installer. Placez la bavette frontale, sans la bloquer, sur la plaque support, alors que la bavette latérale est fixée à l'aide de la vis maintenue contre la plaque support.

### Pièces fonctionnelles (fig. 3)

Une fois l'appareil en place, vérifiez systématiquement l'ensemble des pièces fonctionnelles. Ces pièces doivent pouvoir s'extraire facilement et fonctionner correctement.

# FRANCAIS

## Commande d'entrée d'air (A)

Position gauche = fermé. Position droite = ouvert.

## Poignée de porte (B)

Vers la gauche = ouverte. Vers la droite = fermée.

## Poignée de porte (C)

Vers la droite = ouverte. Vers la gauche = fermée.

## Cendrier (E)

Ouvrez la porte en tournant le bouton dans le sens contraire des aiguilles d'une montre sur un demi-tour. Utilisez un gant ou autre pour extraire le tiroir à cendres.

**Attention ! Enlevez les cendres uniquement lorsque le poêle est froid.**

## Montage du conduit de raccordement

Il est conseillé de procéder à des essais de montage avant de pratiquer l'orifice dans la cheminée. Reportez-vous à la **fig. 2** pour connaître les dimensions requises en cas d'installation contre un mur constitué de matériaux inflammables. Le poêle est muni d'une buse de Ø 150 mm qui est placée à l'intérieur pour le transport.

**Vous pouvez opter soit pour une sortie par l'arrière, soit par le dessus. Les vis de fixation se trouvent dans le sachet de visserie joint.**

- L'adaptateur ou le tuyau de Ø 150 mm est connecté directement à la buse. Une vis est située de part et d'autre de la buse (**fig. 4-A**). Elles permettent de fixer l'adaptateur ou le tuyau.
- Repérez l'endroit où les vis entrent en contact avec l'adaptateur ou le tuyau, lorsque ce dernier se trouve complètement enfoncé dans la buse. Puis percez un trou de 5,5 mm destiné à accueillir la vis de fixation de l'adaptateur ou du tuyau.
- Utilisez du joint corde et du mastic réfractaire pour assurer l'étanchéité entre l'adaptateur ou le tuyau et la circonférence de la buse. Placez le joint corde autour de la partie inférieure de l'adaptateur ou du tuyau et comblez l'espace restant avec le mastic réfractaire.
- Fixez l'adaptateur ou le tuyau à l'aide des vis.

**Attention ! Les joints doivent être parfaitement étanches. Toute fuite d'air risque d'entraver le bon fonctionnement du poêle.**

## Raccordement à la cheminée

Percez un trou adapté au conduit de raccordement. La distance entre le poêle et le mur/cheminée doit être conforme à celle indiquée sur **les figures 2**.

Le tuyau entre le poêle et le conduit de cheminée doit être au minimum parfaitement horizontal. Une légère inclinaison montante du poêle vers la cheminée est recommandée.

# Consignes de fonctionnement

## Mise en service et usage courant

Le poêle Jøtul F 600 est un appareil à combustion non polluante doté d'une double chambre de combustion spéciale qui assure la postcombustion des gaz et des particules toxiques. Il est donc important que ce système soit utilisé correctement.

Le poêle est doté de certaines fonctions qui sont décrites dans ce chapitre : Pièces fonctionnelles.

## Mise en service

Ouvrez à fond la commande d'entrée d'air en la poussant complètement à droite (**fig. 3-A**). Placez un peu de papier froissé, du petit bois et quelques bûches dans le foyer, puis allumez le feu. Ajoutez progressivement d'autres bûches et laissez brûler à feu vif pendant quelques heures. Laissez le feu s'éteindre et répétez l'opération une seconde fois.

**Attention ! Des odeurs peuvent se répandre lors de la première utilisation.**

*Appareils peints* : Lors de sa première utilisation, le poêle risque d'émettre un gaz irritant et de répandre des odeurs. Bien que ce gaz ne soit pas toxique, il est recommandé d'ouvrir une fenêtre ou une porte afin d'aérer la pièce. Laissez le feu brûler à grand tirage jusqu'à la disparition complète des gaz et des odeurs.

*Appareils émaillés* : Une certaine condensation peut se former à la surface du poêle lors de ses premières utilisations. Nettoyez régulièrement ces traces de condensation avec un chiffon doux et sec afin d'éviter la formation de taches permanentes lorsque la surface est chaude.

**Lors de la première chauffe, maintenir les portes ouvertes et essuyer attentivement les parties émaillées qui entrent en contact avec les joints.**

## Usage courant

Utilisez de vieux journaux et du petit bois pour allumer vos feux. Placez deux bûches de taille moyenne de chaque côté du socle. Placez du papier froissé (ou des écorces de bouleau) entre ces bûches et ajoutez un peu de petit bois en vrac par-dessus, puis allumez le feu. Ajoutez progressivement d'autres bûches.

**Commande d'entrée d'air (fig. 3-A)**. Réglez l'entrée d'air lorsque le bois est bien allumé et brûle correctement. Vérifiez que la postcombustion (deuxième combustion) se produit. Cette combustion se caractérise par la présence de flammes jaunes et dansantes dans le foyer. La double

combustion s'effectue lorsque le poêle fonctionne entre le ralenti et mi-puissance. Adaptez ensuite la combustion au niveau de chauffage souhaité en réglant l'entrée d'air.

*Utilisez toujours* du bois de bonne qualité. Il permet d'obtenir un meilleur rendement et n'endommage pas le produit.

**Ne faites jamais brûler les matériaux suivants dans votre poêle :**

- déchets ménagers, sacs plastique, etc.
- bois peint ou imprégné (fortement toxique)
- plaques d'aggloméré ou de contreplaqué
- bois de récupération

*Ces matériaux risquent d'endommager l'appareil et de polluer l'atmosphère.*

**Attention ! N'employez aucune substance inflammable (essence, kérosène ou autre alcool) pour allumer un feu. Vous risquez de vous brûler et d'endommager l'appareil.**

**Attention ! Danger de surchauffe : Le poêle ne doit jamais être utilisé en régime de surchauffe.**

Le poêle risque une surchauffe si vous y insérez une quantité excessive de bois et/ou si vous laissez l'entrée d'air entièrement ouverte trop longtemps.

*Le tirage de la cheminée ne doit jamais excéder 2,5 mmVs (25 Pa).* Les surchauffes s'annoncent par le rougeoiement de certaines parties du poêle. Si vous constatez le moindre rougeoiement, fermez l'entrée d'air aussitôt.

**Attention !** Laissez chaque bûche se consumer totalement avant d'en ajouter d'autres.

## Entretien

### Nettoyage de la vitre

Le poêle Jøtul F 600 est équipé d'un système d'entrée d'air par le haut de la chambre de combustion. Cet air circule devant la vitre avant d'alimenter le feu en oxygène. Ce passage de l'air devant la vitre permet de réduire et retarder son encrassement par la suie.

Toutefois, on ne peut empêcher une certaine quantité de suie de se déposer sur la vitre ; cette quantité est fonction des conditions de tirage et du réglage de l'entrée d'air. Une bonne partie de cette suie s'élimine en brûlant : il convient pour ce faire de pratiquer des feux très vifs pendant quelques minutes à chaque rechargement du poêle en bois.

**Un bon conseil :** Pour les opérations courantes de nettoyage, humidifiez un essuie-tout à l'eau chaude et imprégnez-le de quelques cendres prélevées dans la chambre de combustion. Frottez la vitre avec ce papier, puis rincez à l'eau propre. Pour un nettoyage plus complet, nous vous recommandons d'utiliser un produit spécial pour cet usage.

### Retrait des cendres

Le poêle Jøtul F 600 est équipé d'un cendrier qui facilite l'élimination des cendres.

Faites tomber les cendres dans le cendrier. Utilisez un gant pour saisir la poignée amovible du cendrier et déversez la cendre. Nous vous recommandons de laisser le cendrier se remplir et de toujours laisser quelques centimètres de cendres au fond de l'appareil. Celle-ci protégera la sole foyère et conservera les braises pour une efficacité plus grande. Evitez de manipuler la porte du cendrier :

**Assurez-vous que la porte du cendrier est correctement fermée lors de l'utilisation du poêle.**

Voir aussi la manière de manipuler les cendres dans la section « Mesures de prévention des incendies ».

### Nettoyage et élimination de la suie

A l'usage, des dépôts de suie risquent de se former sur les surfaces internes du poêle. La suie étant un isolant efficace, elle amoindrit les capacités calorifiques de votre poêle. Vous pouvez facilement éliminer ces dépôts de suie accumulée en utilisant un produit spécial pour cet usage.

Il est également indispensable de nettoyer chaque année l'intérieur de l'appareil afin d'en optimiser le rendement. Il peut être judicieux de procéder à ce nettoyage annuel lors du ramonage de la cheminée et des conduits de raccordement.

# FRANCAIS

## Nettoyage des conduits de raccordement menant à la cheminée

Le ramonage des conduits de raccordement s'effectue en soulevant la plaque supérieure ovale amovible. Cela facilite l'accès pour effectuer le ramonage. Il est possible de procéder au ramonage par l'ouverture de la porte du poêle. Dans ce cas, le déflecteur doit être préalablement déposé. Voir les sections correspondantes dans le chapitre : **Révision**.

## Contrôle du poêle

Jøtul vous recommande d'effectuer vous-même un contrôle du poêle après l'avoir essuyé/nettoyé. Vérifiez l'absence de fissures sur les surfaces visibles. Vérifiez également l'étanchéité et le positionnement des joints. Tout joint visiblement usé ou endommagé doit être remplacé.

Nettoyez soigneusement les rainures des joints, appliquez de la colle haute température (disponible chez votre revendeur local Jøtul) et remettez les joints en place en veillant à les fixer fermement **sans les étirer**. La colle haute température séchera rapidement.

## Entretien extérieur

Les appareils peints peuvent changer de couleur après plusieurs années d'utilisation. Brossez et essuyez la surface afin d'éliminer toutes les particules avant d'appliquer une nouvelle couche de peinture de type Jøtul.

Les appareils émaillés doivent être essuyés à l'aide d'un chiffon uniquement. Ne pas utiliser d'eau ni de savon. Toute tache peut être éliminée à l'aide de nettoyeurs liquides doux.

## Longueur, quantité et qualité des bûches

La longueur maximale des bûches doit être de **55 cm**. Les bûches doivent être placées parallèlement à la paroi du fond de la chambre de combustion. L'appareil Jøtul F 600 possède une capacité calorifique **minimum de 3,5 kW**, et une capacité **nominale de 10,0 kW**. Selon nos calculs, la capacité nominale s'obtient en brûlant 4,0 kg de bois de bonne qualité par heure.

## Qualité du bois selon Jøtul

Le bois de bonne qualité doit être séché de manière à ne retenir qu'une teneur en eau inférieure à 20%. Pour cela, le bois doit être coupé de l'automne à la fin de l'hiver, puis séché à l'air libre. Les bûches doivent être disposées de manière à faciliter la circulation de l'air et recouvertes pour le protéger de la pluie (sauf le chêne et le châtaigner). Ce séchage à l'air libre doit durer au minimum 24 mois après la coupe. Pour le chêne et la châtaigner, le lavage à la pluie doit durer un an. Au début de l'automne, les bûches doivent être rentrées à l'abri et empilées en vue

d'un usage pour l'hiver prochain. Nous considérons que les bois suivants sont de bonne qualité: le charme, le chêne, le frêne, l'érable, le bouleau etc.

La masse énergétique d'un kilogramme de bois varie peu d'un type de bois à l'autre. En revanche, leur masse volumique est très variable. Par exemple, un certain volume de bouleau produira un nombre de kWh inférieur à celui du même volume de chêne, lequel possède une masse volumique plus importante.

La masse énergétique d'un kilogramme de bois de bonne qualité est d'environ 3,8 kWh. 1 kg de bois complètement sec (0 % d'humidité) produit environ 5 kWh, alors que du bois dont le niveau d'humidité est de 60 %, produit seulement environ 1,5 kWh/kg.

## Révision

### Changement des plaques de doublage

- Le poêle est équipé de plaques de doublage latérales et arrière. La plaque de doublage montée sur la porte de droite est fixée à l'aide d'une vis.
- Desserrez la vis pour déposer les plaques.
- Pour les réinstaller, suivre la même méthode à l'envers.

### Changement du déflecteur

- Le déflecteur comprend 2 plaques de fonte et repose sur les conduits de la double chambre de combustion.
- Pour déposer les plaques, enlevez l'isolant en fibres de céramique qui est posé dessus. Soulevez-les légèrement vers le haut en les maintenant au milieu, puis retirez-les.
- Pour les réinstaller, replacer les deux plaques en suivant la même procédure à l'envers. Assurez-vous qu'elles viennent en butée contre la paroi arrière.
- Puis, remplacez l'isolant en fibres de céramique.

## Équipements optionnels

### Branchement du conduit de ventilation externe - n° de pièce 221032

A l'aide d'un branchement du conduit de ventilation externe et de tuyaux flexible, l'air de combustion peut arriver directement de l'extérieur dans le poêle. Ainsi, sera-t-il toujours alimenté suffisamment en air pour fournir une combustion appropriée.



## Índice de contenido

### Relación con las autoridades de distintos países

Información técnica de la estufa Jøtul F 600 .....	37
Medidas de seguridad generales .....	37
Medidas para prevención de incendios .....	37

### Instalación de Jøtul F 600

Cimientos .....	37
Chimenea .....	37
Circulación de aire .....	37
Montaje previo a la instalación .....	38
Control de funciones .....	38
Instalación del conducto de humos .....	38
Conexión a la chimenea .....	38

### Instrucciones de funcionamiento

Encendido inicial y uso diario .....	39
Encendido inicial .....	39
Uso diario .....	39

### Mantenimiento

Limpieza del cristal .....	40
Eliminación de la ceniza .....	40
Limpieza y eliminación del hollín .....	40
Deshollinar los tubos de humos a la chimenea .....	40
Control de la estufa .....	40
Mantenimiento externo .....	40
Longitud, cantidad y calidad de los troncos .....	40
Definición de madera de buena calidad de Jøtul .....	40

### Conservación

Cambio de los quemadores .....	41
Cambio de la placa deflectora .....	41

### Equipo opcional

Tubo de conexión para ventilación externa .....	41
-------------------------------------------------	----

Figuras - dibujos .....	59
-------------------------	----

## Relación con las autoridades de distintos países

Jøtul F 600 es un producto que no deja residuos de combustión.

La placa de características del producto se incluyen con instrucciones para instalación. En esta placa figura la siguiente información: Fabricante y dirección, número de modelo, número de fabricación, producción térmica estimada, número de registro (después de haberla asignado), estilto y medidas de seguridad. La placa de características puede acoplarse en la parte posterior de la etiqueta de aprobación de EE.UU. o en la parte posterior de la pantalla térmica. (La pantalla térmica se vende por separado.)

**La instalación de una chimenea debe ajustarse a las leyes y regulaciones de cada país. Póngase siempre en contacto con el inspector de construcción local o con la autoridad pertinente responsable de los reglamentos y las ordenanzas locales en su zona. Su proveedor ha sido seleccionado especialmente por su conocimiento de las regulaciones locales y puede proporcionar la asistencia necesaria para garantizar la seguridad y legalidad de su instalación.**

**Advertencia :** Es necesario asegurarse de que exista la ventilación adecuada en la habitación en la que va a instalarse la estufa.

**La carencia de una ventilación adecuada puede producir una disminución del nivel de oxígeno de la habitación. Como consecuencia, puede experimentarse cansancio, náuseas y malestar, lo que resulta muy peligroso.**

Es importante asegurarse de que la chimenea tenga las dimensiones correctas para la estufa y que la conexión a la chimenea esté sellada y funcione correctamente. La entrada de humo del gas en espacios cerrados puede representar un peligro grave para la salud.

Las instrucciones de montaje, instalación y del usuario se incluyen con el producto. La instalación sólo puede utilizarse una vez que haya sido inspeccionada por un controlador cualificado.

### Información técnica de la estufa Jøtul F 600:

Material:	Hierro fundido
Acabado:	Pintura negra, esmalte negro azulado/ verde
océano y añil	
Combustible:	Madera
Longitud máxima de los troncos:	55 cm
Sistema de tiro:	Tiro superior e inferior
Sistema de combustión:	Combustión secundaria
Salida de humos:	Superior/trasera
Dimensión del tubo de humos:	150 mm de diámetro
Posibilidad de adaptar un tubo de acero:	Sí
Peso aprox.:	200 kg
Medidas del producto, medidas de la distancia hasta muro protegido/ desprotegido:	Ver las fig. 1 y 2.

### Medidas de seguridad generales

**Requisitos para la plancha del suelo:** Si la estufa se va a instalar sobre un suelo fabricado de un material inflamable, todo el suelo situado debajo de la estufa, y al menos 500 mm en la parte frontal y derecha de la estufa, deberá estar cubierto de una plancha fabricada de un material no inflamable. Las dimensiones de la plancha dependerán de las ordenanzas y los reglamentos locales y se recomienda ponerse en contacto con el distribuidor local de productos Jøtul antes de proceder a la instalación. (Vea la fig. 2).

#### Distancia hasta el muro de material inflamable:

Póngase en contacto con las autoridades de construcción locales para solicitar información sobre las restricciones y los requisitos de instalación.

La puerta lateral del producto no se debe utilizar cuando se instala la estufa en un hueco o una esquina.

**Aislamiento del tubo de humos:** Si los tubos de humos sin aislamiento atraviesan suelos o paredes, establecen que la abertura debe ser de ladrillo o albañilería, de forma que la superficie exterior del tubo no se acerque a menos de **230 mm** de los materiales inflamables. Los tubos de humos aislados pueden quedar a otra distancia, si es necesario consulte el tubo de humos correcto en la documentación técnica de seguridad contra incendios del producto.

### Medidas para prevención de incendios

Cada vez que utilice la chimenea puede existir cierto peligro. Por lo tanto, debe respetar las instrucciones siguientes:

- Utilice siempre un parachispas si se va a utilizar el producto con una puerta abierta.
- Asegúrese de que el mobiliario y otros materiales inflamables no estén demasiado próximos a la chimenea.

- Debe haber una distancia despejada mínima de 800 mm desde la parte frontal de la chimenea.
- Deje que el fuego se consuma. Nunca lo apague con agua porque podría dañar el producto.
- La chimenea se calienta durante su uso y puede causar quemaduras si se toca.
- La ceniza debe eliminarse adecuadamente al aire libre o vaciarse en un lugar que no represente un peligro de incendio. Consulte las regulaciones locales.
- Todas las estufas deben tener un depósito de almacenamiento fabricado con material no inflamable como accesorio estándar para la eliminación segura del hollín y las cenizas. Éstos deben guardarse en el depósito durante al menos una semana para que se extingan los últimos rescoldos. Si tiene que vaciar el depósito antes de este tiempo, deberá llenarlo de agua y agitarlo.
- Puede que quiera guardar la ceniza porque es un excelente fertilizante para las rosas y otras plantas.

### Instalación de Jøtul F 600

**Nota:** Compruebe que la estufa no presenta daños antes de comenzar la instalación.

**El producto pesa mucho, por lo que necesitará ayuda para levantarlo e instalarlo.**

### Cimientos

Si Jøtul F 600 se va a instalar sobre un suelo de madera, asegúrese de que el suelo que soporta la estufa tiene las dimensiones suficientes para ello.

### Chimenea

La estufa puede conectarse a una chimenea de ladrillo, elemental prefabricada o de acero Jøtul. **Vea la sección correspondiente.** La sección transversal de la chimenea debe ser al menos de 177 cm<sup>2</sup> (equivalente a 150 mm de diámetro). La conexión a la chimenea debe realizarse de acuerdo con las instrucciones de instalación del proveedor de la chimenea.

### Circulación de aire

El uso de una chimenea requiere un abundante suministro de aire puro a la habitación donde se ha instalado el producto. Si la casa está cerrada herméticamente, la habitación debe equiparse con un suministro adicional de aire puro a través de respiraderos. Evite el uso de ventiladores en las habitaciones donde haya chimeneas porque podrían causar una presión negativa y aspirar gases venenosos dentro de la habitación. Para evitarlo, es posible introducir directamente aire del exterior a la estufa mediante un adaptador (elemento opcional) que se monta en la entrada de aire de la estufa. Desde allí se dirige un tubo flexible al exterior de la vivienda. Las instrucciones de instalación se incluyen con la unidad de instalación.

# ESPAÑOL

## Montaje previo a la instalación

El producto se entrega en un solo embalaje. También se incluye un tirador suelto para utilizar con la puerta.

La placa superior ovalada está fijada con tornillos durante el transporte. Retire los tornillos del fondo de la placa superior y déjela sin fijar. De esta manera será más fácil deshollinar la chimenea cuando sea necesario limpiar el producto y el conducto de humos.

Desmante las sujeciones del cenicero, que está sujeto a la parte superior, e instale. La parte frontal está suelta en la parte superior de la placa base, mientras que la lateral está sujeta con un tornillo fijado a la placa base.

## Control de funciones (fig. 3)

Cuando el producto esté instalado, compruebe siempre las funciones de control, que deberán moverse con facilidad y funcionar correctamente.

### Respiradero de tiro (A)

Posición izquierda = cerrados.

Posición derecha = totalmente abiertos.

### Tirador de la puerta (B)

A la izquierda = abierta. A la derecha = cerrada.

### Asa de la puerta (C)

A la derecha = abierta. A la izquierda = cerrada.

### Puerta de recogida de ceniza (E)

Abrir la puerta haciendo girar el tirador media vuelta en sentido contrario a las agujas del reloj. Utilice un guante o un trapo para extraer la bandeja.

**Nota:** Retire las cenizas sólo cuando se haya enfriado la estufa.

## Instalación del conducto de humos

Es aconsejable realizar un montaje de prueba antes de practicar un orificio en la chimenea. Vea en **la fig. 2** las medidas de la distancia a la pared de material inflamable. La estufa se instala con un conducto de humos de 150 mm de diámetro, que debe tener un grosor aprobado.

Durante el transporte, el conducto de humos de la estufa Jøtul F 600 se encuentra en el interior de la cámara de combustión. Puede elegir una salida superior o posterior desde el conducto de humos. Los tornillos de fijación se encuentran en la bolsa que contiene los tornillos.

- Los conductos de humo de 150 mm de diámetro se colocan directamente sobre la salida de humos del producto. Hay un tornillo a cada lado de la salida de humos del producto (**fig. 4-A**), que se utilizan para asegurar el tubo del conducto de humos.
- Marque la posición donde los tornillos entran en contacto con el tubo del conducto de humos cuando se encuentra en la posición más baja de la salida de humos y taladre un orificio de 5,5 mm para el tornillo en el tubo del conducto de humos.

- Utilice una junta y cemento para sellar la unión entre el tubo del conducto de humos y la salida de humos del producto. Coloque la junta alrededor de la parte inferior del tubo del conducto de humos y llene el espacio con cemento.
- Asegure el tubo del conducto de humos con los tornillos.

**Nota:** Es importante que las uniones estén bien selladas. Las fugas de aire, por ejemplo, pueden ser causa de un funcionamiento defectuoso.

## Conexión a la chimenea

Taladre un orificio para el tubo de humos. La distancia desde la estufa al muro cortafuegos/chimenea debe ser la indicada en **las fig. 2**. Utilice siempre un collar de chimenea cuando acople la estufa a la chimenea. Use el collar de chimenea recomendado por el proveedor cuando conecte la estufa a una chimenea elemental. Siga atentamente las instrucciones de uso y de montaje del proveedor con respecto al mortero o el cemento de horno antes de utilizar la chimenea.

Asegúrese de que el tubo de humos nunca se inclina hacia la chimenea. Al menos debería estar horizontal, preferiblemente tener una inclinación de unos pocos milímetros.

**Nota:** Una conexión correcta y hermética es muy importante para el funcionamiento adecuado del producto.

Observe que es especialmente importante que las conexiones tengan cierta flexibilidad para evitar que la sedimentación de la casa provoque la formación de grietas.

# Instrucciones de funcionamiento

## Encendido inicial y uso diario

Jøtul F 600 es un producto que no deja residuos de combustión y que, con la ayuda del suministro adicional de aire de combustión, permite la combustión retardada de los gases y partículas peligrosas. Es muy importante utilizar correctamente el sistema.

La estufa está equipada con determinadas funciones que se describen en el capítulo: Control de funciones.

## Encendido inicial

Abra totalmente el respiradero de tiro empujando el respiradero completamente a la derecha (**fig. 3-A**). Coloque papel de periódico arrugado, astillas de madera y leña, y encienda un fuego pequeño. Vaya añadiendo leña de forma gradual y deje que arda un fuego vivo durante varias horas. Deje que se extinga el fuego y repita el procedimiento otra vez.

**Nota: Olores cuando se utiliza la estufa por primera vez.**

*Productos pintados:* La primera vez que se enciende la estufa, puede emitir un gas irritante y oler ligeramente. El gas no es tóxico, pero se aconseja abrir una ventana o una puerta para que la habitación esté más ventilada. Deje arder el fuego con un tiro alto hasta que todos los rastros de gas hayan desaparecido y no se detecten humo ni olores.

*Productos esmaltados:* Las primeras veces que se utiliza la estufa, es posible que se forme condensación de agua sobre la superficie. Ésta debe secarse para evitar que se formen manchas permanentes cuando se caliente la superficie.

## Uso diario

Encienda el fuego con la ayuda de papel de periódico y astillas para encender fuego. Coloque dos troncos medianos a cada lado de la base. Coloque entre ellos papel de periódico arrugado (o corteza de abedul) y añada algunas astillas entrecruzadas encima y prenda fuego al papel de periódico. Aumente el tamaño de los troncos de forma gradual.

**Respiradero de tiro (fig. 3-A.)** Regule el tiro cuando la leña haya prendido correctamente y arda bien. Compruebe que se inicia la combustión retardada (combustión secundaria), indicada por la aparición de llamas amarillas oscilantes en la cámara de aire. Seguidamente, regule la velocidad de combustión en el nivel que desee ajustando el respiradero de tiro.

Utilice siempre leña de buena calidad. Proporciona los mejores resultados y no daña el producto.

**Nunca queme los materiales siguientes en la estufa:**

- productos de desecho domésticos, bolsas de plástico, etc.
- madera pintada o impregnada (muy tóxica)
- madera aglomerada o contrachapada
- madera de deriva

*Éstos pueden dañar el producto y contaminar la atmósfera.*

**Nota: Nunca utilice líquidos inflamables como gasolina, queroseno, alcoholes fuertes, etc., para encender el fuego, porque podrían causar daños a usted y al producto.**

**Nota: Peligro de sobrecalentamiento: La estufa no se debe utilizar nunca de manera que se produzca un sobrecalentamiento.**

Se dice que se produce un sobrecalentamiento cuando se coloca una cantidad excesiva de leña en la estufa o se deja completamente abierto el respiradero de tiro.

*El tiro de la chimenea nunca debe superar 2,5 mmVs (25 Pa).* Un signo inequívoco de sobrecalentamiento es cuando partes de la estufa se ponen incandescentes. Cuando ocurra esto, reduzca inmediatamente la abertura del respiradero de tiro.

**Advertencia: Cada fuego debe consumirse hasta que quede un rescoldo, antes de añadir más leña.**

## Mantenimiento

### Limpieza del cristal

Jøtul F 600 está equipado con tiro superior (depuración de aire). A través del respiradero de tiro, el aire se aspira por encima de la chimenea y se depura a lo largo del interior del cristal. Este sistema tiene la ventaja de que mejora la combustión y reduce la acumulación de depósitos de hollín sobre el cristal.

Aunque siempre se adhiere algo de hollín al cristal, la cantidad dependerá de las condiciones de tiro locales y del ajuste del respiradero de tiro. La mayor parte de la capa de hollín se suele quemar cuando se abre completamente el respiradero de tiro y arde un fuego vivo en la chimenea.

**Un buen consejo:** Para la limpieza normal humedezca una toalla de papel en agua caliente y añádale cenizas de la cámara de combustión. Frote el cristal con la toalla de papel y luego límpielo con agua limpia.

### Eliminación de la ceniza

Jøtul F 600 está equipado con una bandeja que facilita la eliminación de cenizas.

Sacuda la ceniza para que caiga a través de la parrilla de la placa base a la bandeja para la ceniza. Utilice un guante o el tirador suelto, sujete el tirador de la bandeja para la ceniza y tire la ceniza. Asegúrese de que la bandeja para ceniza no se llena hasta el punto de impedir que la ceniza caiga a la bandeja a través de la parrilla.

Asegúrese de que la puerta de la bandeja para ceniza está cerrada firmemente mientras se esté utilizando la estufa.

Siempre conviene dejar algunas cenizas en la cámara de combustión como capa protectora contra la base de la estufa. Vea asimismo la descripción donde se explica cómo manipular las cenizas en la sección “Medidas para prevención de incendios”.

### Limpieza y eliminación del hollín

Pueden acumularse depósitos de hollín sobre las superficies internas de la estufa durante su uso. El hollín es un buen aislante y, por lo tanto, reduce la producción de calor de la estufa.

Será necesario limpiar el interior una vez al año para obtener el máximo efecto de calentamiento del producto. Es una buena idea hacerlo cuando desholline la chimenea y los tubos de humos.

### Deshollinar los tubos de humos a la chimenea

Los conductos de humos se deshollinan levantando la placa superior ovalada suelta, que facilita el acceso a los tubos. Es posible deshollinar a través de la trampilla de deshollinamiento del tubo de humos o a través de la abertura de la puerta del producto. En este caso se deberá retirar antes la placa deflectora. Vea las secciones correspondientes en: **Conservación**.

### Control de la estufa

Jøtul le aconseja que controle personalmente la estufa de forma minuciosa después de deshollinar o limpiar. Compruebe si existen fisuras en las superficies visibles. Compruebe también que todas las uniones están selladas y que las juntas están bien colocadas. Deberán cambiarse las juntas que muestren signos de desgaste o deformación.

Limpie a fondo las ranuras de la junta, aplique adhesivo cerámico (disponible en su proveedor Jøtul local) y presione sobre la junta para que encaje en posición. La unión se secará en poco tiempo.

### Mantenimiento externo

Tras algunos años de utilización es posible que los productos pintados sufran una alteración en su color. Debe cepillarse la superficie para limpiarla de partículas sueltas antes de aplicar una pintura para estufa Jøtul nueva.

Los productos esmaltados deben limpiarse únicamente con un paño limpio y seco. No utilice agua jabonosa. Las manchas pueden eliminarse con un líquido de limpieza (un producto para limpiar hornos, etc.).

### Longitud, cantidad y calidad de los troncos

Los troncos que se utilicen deberán tener una longitud máxima de **55 cm**. Colóquelos paralelos a la pared posterior de la cámara de combustión. La emisión de **calor mínima** de Jøtul F 600 es de **3,5 kWh** y la capacidad **nominal es de 10,0 kWh**. Se ha calculado que se necesitarán aproximadamente **4,0 kg** de leña de buena calidad por hora para lograr la emisión de calor nominal.

### Definición de madera de buena calidad de Jøtul

**La madera de buena calidad debe secarse de modo que el contenido de agua sea aproximadamente del 20 al 25%.** Para ello, se debe cortar la madera a finales de invierno o comienzos de la primavera. Después se deberá cortar y apilar para asegurar que se airee correctamente. Se debe cubrir la leña apilada para evitar que absorba demasiada

agua de lluvia. Los troncos deben guardarse en un lugar cerrado en otoño para utilizarlos durante la estación invernal.

Por leña de buena calidad se entiende troncos de árboles como abedul, haya y roble.

La cantidad de energía que se obtiene de 1 kg de madera varía muy poco, pero el peso específico de los diferentes tipos de madera sí varía considerablemente. Por ejemplo, un determinado volumen de abedul proporcionará menos kWh que el mismo volumen de roble, que tiene un peso específico más alto.

La cantidad de energía que proporciona 1 kg de madera de buena calidad es de aproximadamente 3,8 kWh. 1 kg de madera completamente seca (0 % de humedad) produce alrededor de 5 kWh, mientras que la madera con un nivel de humedad del 60 % produce solamente alrededor de 1,5 kWh/kg.

## Conservación

### Cambio de los quemadores

- La estufa dispone de quemadores en los laterales y en la parte trasera. El quemador de la puerta derecha está sujeto con un tornillo.
- Para extraerlo, afloje el tornillos y retire el quemador.
- Para instalar, siga el mismo procedimiento.

### Cambio de la placa deflectora

- La placa deflectora consta de 2 placas de hierro fundido y se apoya sobre los tubos que suministran aire para la combustión secundaria.
- Para retirarla, tire un poco hacia arriba por la mitad y retire las placas.
- Para instalar, vuelva a color las dos placas de la misma forma. Asegúrese de que quedan apoyadas contra la pared posterior.
- A continuación, coloque el manto aislante encima de las placas deflectoras.

## Equipo opcional

### Tubo de conexión para ventilación externa cat. N° 221032

Con la ayuda de un tubo de conexión para ventilación externa y de tubo flexible, se puede conectar el aire de combustión a la estufa de inserción directamente desde el exterior. De esta forma, el hogar siempre tendrá el aire necesario para una combustión correcta.

## Indice generale

### Conformità alle leggi

Dati tecnici di Jøtul F 600 .....	42
Misure di sicurezza generali .....	43
Misure preventive antincendio .....	43

### Installazione di Jøtul F 600

Principi fondamentali .....	43
Cappa .....	43
Circolazione dell'aria .....	43
Montaggio prima dell'installazione .....	43
Controllo delle funzioni .....	44
Montaggio del condotto .....	44
Collegamento alla cappa .....	44

### Istruzioni per il funzionamento

Prima accensione e utilizzo quotidiano .....	44
Prima accensione .....	44
Utilizzo quotidiano .....	45

### Manutenzione

Pulizia del vetro .....	45
Eliminazione della cenere .....	45
Pulizia del camino ed eliminazione della fuliggine .....	45
Pulizia della canna fumaria verso la cappa .....	46
Controllo del camino .....	46
Manutenzione esterna .....	46
Lunghezza, quantità e qualità della legna .....	46
Legna di qualità: Definizione di Jøtul .....	46

### Riparazione

Sostituzione delle piastre refrattarie .....	46
Sostituzione del parafiamma .....	46

### Attrezzatura facoltativa

Condotto di collegamento per la ventilazione esterna ...	46
----------------------------------------------------------	----

Figure - disegni .....	59
------------------------	----

## Conformità alle leggi

Jøtul è un prodotto a combustione pulita.

La piastra informativa del prodotto, in materiale refrattario, si trova con il manuale di installazione nel prodotto. Sulla piastra informativa si trovano le seguenti informazioni: Produttore e indirizzo, numero del modello, numero di serie, uscita di calore prevista, numero di registrazione (dopo l'assegnazione), modello e misure di sicurezza. La piastra informativa può essere applicata sul retro della targhetta recante l'approvazione americana o sul retro dello scudo termico. (Lo scudo termico è venduto separatamente).

L'installazione di una stufa deve essere eseguita in conformità ai codici e alle norme locali di ogni paese. Contattare sempre l'ispettore edile locale o l'autorità responsabile dei codici e delle norme locali nella vostra zona. Il rivenditore locale è stato appositamente selezionato per la sua conoscenza dei codici locali e potrà fornire l'assistenza necessaria per assicurare un'installazione sicura e conforme alla legge.

**Attenzione!** Assicurarsi che nella stanza in cui verrà installata la stufa vi sia una ventilazione adeguata. Un'insufficiente ventilazione può dare luogo a carenza di ossigeno nella stanza. Ciò può causare sonnolenza, nausea e vomito ed è estremamente pericoloso.

È importante accertarsi che le dimensioni del camino siano adatte alla stufa e che l'attacco al camino sia sigillato e funzioni correttamente. I gas prodotti dal fumo che penetra in spazi chiusi possono rappresentare un rischio molto grave per la salute.

Le istruzioni per l'assemblaggio, l'installazione e l'uso sono fornite con il prodotto. L'installazione può essere messa in funzione solo dopo l'ispezione da parte di un tecnico qualificato.

### Dati tecnici di Jøtul F 600:

Materiale:	Ghisa
Rivestimento esterno:	Vernice nera, smalto blu notte e verde mare.
Combustibile:	Legna
Lunghezza massima dei ciocchi:	55 cm
Sistema di tiraggio:	Tiraggio superiore e inferiore
Sistema di combustione:	Combustione secondaria
Scarico fumi:	Alto/posteriore
Dimensione condotto del fumo:	150 mm di diametro
È possibile fissare il condotto in acciaio?	Sì
Peso approssimativo:	200 kg
Accessori opzionali:	Scudo termico inferiore scudo termico posteriore

Misure del prodotto, distanze dalla parete refrattaria/non protetta. Vedere **figg. 1 e 2**.

## Misure di sicurezza generali

Requisiti dello schermo per pavimento: Se la stufa deve essere installata su un pavimento in materiale infiammabile, l'intera superficie sottostante la stufa e davanti e a destra della stessa per almeno 500 mm dovrà essere ricoperta da una piastra di materiale non infiammabile. La dimensione della piastra dipende dalle norme locali. (Vedere misure in **fig. 2**).

**Distanza del prodotto da pareti costruite con materiale infiammabile:** Si raccomanda di contattare il rivenditore Jøtul locale prima di procedere all'installazione.

Lo sportello laterale del prodotto non deve essere utilizzato se la stufa viene installata in un angolo.

**Condotto del fumo in materiale isolante:** Se i condotti del fumo non isolanti devono passare attraverso pareti o pavimenti, le aperture, in base agli standard statunitensi, devono essere di mattoni o in muratura, in modo che la distanza tra la superficie esterna del condotto e il materiale infiammabile sia superiore a **230 mm**. I condotti del fumo isolanti possono avere una distanza diversa: Se necessario, consultare la documentazione tecnica relativa al condotto del fumo.

## Misure preventive antincendio

L'utilizzo di un camino può costituire un pericolo. Si raccomanda pertanto di attenersi alle istruzioni seguenti:

- Se si usa il prodotto con uno sportello aperto, utilizzare sempre un parascintille.
- Assicurarsi che mobili e altro materiale infiammabile non siano mai troppo vicini al camino. È necessario che vi sia una distanza di almeno 800 mm dalla parte anteriore del camino.
- Lasciare che il fuoco si esaurisca. Non adoperare mai acqua per spegnere il fuoco poiché in questo modo si potrebbe danneggiare il camino.
- Il camino si scalda quando è utilizzato e, se toccato, può provocare ustioni.
- La cenere deve essere smaltita all'esterno oppure in un luogo in cui non costituisca un potenziale pericolo. Fare riferimento alle norme locali.
- Ogni camino deve essere provvisto di un apposito contenitore in materiale ignifugo come accessorio standard per la raccolta sicura di fuliggine e ceneri. Fuliggine e ceneri devono restare in questo contenitore almeno una settimana, per essere sicuri che le braci siano spente. Se occorre svuotare il contenitore prima che sia trascorso questo periodo, versare abbondante acqua all'interno del contenitore e miscelare.
- La cenere può essere conservata, in quanto costituisce un ottimo fertilizzante per rose e altre piante.

## Installazione di Jøtul F 600

**Nota:** Prima di procedere all'installazione, ispezionare il camino e accertarsi che non sia danneggiato.

**Il camino è pesante! Chiedere aiuto quando lo si solleva e lo si installa.**

## Principi fondamentali

Se Jøtul F 600 deve essere installato su un pavimento di legno, assicurarsi che la superficie sottostante abbia le dimensioni adeguate per sostenerlo.

## Cappa

È possibile collegare il camino ad un elemento prefabbricato costruito in mattoni o una cappa Jøtul in acciaio. Vedere sezione a parte. La sezione trasversale minima della cappa deve essere di 177 cm<sup>2</sup> (che corrisponde a 150 mm di diametro). Il collegamento alla cappa deve essere effettuato in conformità alle istruzioni di installazione fornite dal produttore della stessa.

## Circolazione dell'aria

L'utilizzo di un camino richiede un abbondante flusso d'aria fresca nella stanza in cui viene installato il prodotto. Se la casa è sigillata, la stanza deve essere dotata di ventole che consentano un flusso d'aria fresca supplementare. Evitare l'utilizzo di ventole meccaniche dove è presente un camino. Questo tipo di ventola potrebbe causare una pressione negativa e introdurre gas velenosi all'interno della stanza.

Per evitare tale rischio, è possibile convogliare l'aria dall'esterno direttamente nella stufa mediante un adattatore (extra) montato sul bocchettone di entrata dell'aria della stufa. Da qui si dirige un tubo flessibile verso l'esterno dell'edificio. Le istruzioni di installazione vengono fornite insieme all'unità di installazione.

## Montaggio prima dell'installazione

Il prodotto viene consegnato in un singolo imballo. Venga inoltre forniti una maniglia a parte da utilizzare per lo porta.

La piastra ovale è fissata con delle viti durante il trasporto. Rimuovere le viti da sotto la lastra superiore e lasciarla libera. Ciò rende più facili le operazioni di pulizia del camino e della canna fumaria.

Staccare le alette per la cenere fissate alla sommità e procedere all'installazione. L'aletta anteriore è posizionata a parte sulla sommità della piastra, mentre l'aletta laterale è fissata con la vite connessa alla piastra di base.

# ITALIANO

## Controllo delle funzioni (fig. 3)

Quando il prodotto è installato, controllare sempre le funzioni di controllo. È necessario che si muovano con facilità e che funzionino in maniera soddisfacente.

### Ventola di tiraggio (A)

Posizione sulla sinistra = chiusa

Posizione sulla destra = completamente aperta

### Maniglia (B)

Verso sinistra = aperto. Verso destra = chiuso.

### Maniglia (C)

Verso destra = aperto. Verso sinistra = chiuso.

### Sportello del ceneraio (E)

Ruotare la manopola in senso orario di mezzo giro. Utilizzare un guanto o altra protezione per estrarre il vassoio.

**Nota: Rimuovere la cenere solo quando la stufa è fredda.**

## Montaggio del condotto

È consigliabile effettuare un montaggio di prova prima di fare un buco nel camino. Vedere la **fig. 2** per le misure dal muro costruito in materiale non infiammabile.

La stufa viene installata con un condotto di 150 mm di diametro. Questo spessore deve essere approvato.

Durante il trasporto, l'apertura di uscita della Jøtul F 600 si trova nella camera di combustione. È possibile scegliere di posizionare l'uscita del condotto sulla parte superiore o posteriore. Le viti per il fissaggio si trovano nell'apposito contenitore.

- I condotti da 150 mm di diametro sono posizionati direttamente sull'apertura di uscita della stufa. Su entrambi i lati dell'uscita si trova una vite (**fig. 4-A**). Le due viti servono a fissare il condotto.
- Segnare con una matita il punto in cui le viti toccano il condotto quando esso si trova al fondo dell'apertura di uscita della stufa e praticare quindi un foro da 5,5 mm nel condotto.
- Utilizzare una guarnizione e del cemento per sigillare il condotto all'attacco sulla stufa. Posizionare la guarnizione sulla parte inferiore del condotto e riempire lo spazio vuoto con il cemento.
- Fissare il condotto con le viti.

**Nota: Le giunzioni devono essere completamente sigillate. Eventuali fuoriuscite d'aria potrebbero causare un cattivo funzionamento.**

## Collegamento alla cappa

Praticare un foro per il condotto del fumo. La distanza tra la stufa e la parete refrattaria/camino deve essere pari a quella mostrata nelle **figg. 2**. Utilizzare sempre un collare per camini quando si collega la stufa al camino. Utilizzare il collare consigliato dal rivenditore quando si effettua il collegamento ad una cappa a elementi. Attenersi strettamente alle istruzioni di montaggio e utilizzo del fornitore facendo attenzione al cemento della camera di combustione prima di iniziare a utilizzare il camino.

Accertarsi che il condotto del fumo non sia inclinato verso la cappa. Dovrebbe essere almeno orizzontale, o meglio inclinato di qualche millimetro.

**Nota : Un collegamento corretto ed ermetico è molto importante per il funzionamento corretto del prodotto.**

È particolarmente importante che i collegamenti abbiano una certa flessibilità. Ciò serve a prevenire la formazione di crepe dopo avere installato il camino.

## Istruzioni per il funzionamento

### Prima accensione e utilizzo quotidiano

Jøtul F 600 è un prodotto a combustione pulita che, grazie ad una camera d'aria, sottopone particelle e gas nocivi a una seconda combustione. È di estrema importanza utilizzare il sistema correttamente.

La stufa presenta alcune funzioni descritte nel capitolo: Controllo delle funzioni.

### Prima accensione

Aprire (**fig. 3-A**). Inserire alcuni giornali accartocciati, fascine e legna da ardere per accendere un piccolo fuoco. Aggiungere gradualmente altra legna e lasciare che il fuoco bruci vivacemente per alcune ore. Lasciare estinguere il fuoco e ripetere ancora una volta.

**Nota: Odori emanati durante il primo utilizzo del camino.**

**Prodotti verniciati:** È probabile che quando si accende il fuoco per la prima volta, il camino emetta un gas irritante ed emani un odore sgradevole. Il gas non è tossico, ma si consiglia di aprire una finestra o una porta per consentire una maggiore ventilazione nella stanza. Lasciare che il fuoco bruci con un tiraggio elevato fino a che tutte le tracce di gas scompaiono e non sono più presenti fumo e cattivi odori.

**Prodotti smaltati:** Le prime volte che si utilizza un camino nuovo può formarsi sulla superficie del camino acqua di condensa. Rimuovere tale condensa per impedire la formazione di macchie permanenti quando la superficie si riscalda.

## Utilizzo quotidiano

Accendere il fuoco con giornali e legna minuta. Aggiungere due ciocchi di dimensioni medie su ogni lato della base. Inframmezzare i ciocchi con fogli di giornale accartocciati (o con trucioli), quindi disporre delle fascine di legna incrociate sopra il tutto e dare fuoco ai giornali. Aumentare gradualmente la dimensione dei ciocchi aggiunti.

**Ventola di tiraggio (fig. 3-A).** Regolare quando il legno ha preso adeguatamente fuoco e brucia bene. Controllare che si sia verificata la seconda combustione. Ciò viene indicato da fiamme gialle e sfarfallanti nella camera d'aria. Regolare quindi il tasso di combustione sul livello desiderato di riscaldamento, regolando la ventola di tiraggio.

Utilizzare sempre legna da ardere di qualità. Questa legna fornisce i risultati migliori e non danneggia il prodotto.

### Non bruciare mai nel camino i materiali sotto elencati:

- rifiuti domestici, sacchetti di plastica e così via.
- legname verniciato o impregnato, estremamente tossico
- cartone per scatole o fogli di laminato
- legname trovato in mare

*Questi materiali potrebbero danneggiare il prodotto e inquinare l'atmosfera.*

**Nota: Non utilizzare mai liquidi infiammabili come benzina, cherosene, alcol denaturato o simili per accendere il fuoco. Ciò potrebbe causare danni sia a voi che al prodotto.**

**Nota: Pericolo di surriscaldamento. La stufa non deve mai essere utilizzata in maniera da provocare il surriscaldamento.**

Il surriscaldamento si verifica quando si colloca una quantità eccessiva di legna nel camino e/o quando si lascia la ventola di tiraggio completamente aperta.

*Il tiraggio del camino non deve eccedere 2,5 mmVs (25 Pa). Se una qualsiasi parte del camino appare incandescente, significa che la temperatura è troppo elevata. Se ciò accade, ridurre immediatamente l'apertura della ventola di tiraggio.*

**Attenzione! Il fuoco dovrebbe bruciare sino alla cenere prima di aggiungere nuova legna.**

## Manutenzione

### Pulizia del vetro

Jøtul F 600 è dotato di valvola di accensione (air wash). Attraverso la ventola di tiraggio l'aria è risucchiata all'interno sopra il camino e spinta verso il basso lungo la parte interna del vetro. Questo sistema assicura una migliore combustione e riduce il deposito di fuliggine sul vetro.

Sarà comunque inevitabile l'accumulo di un po' di fuliggine sul vetro e la sua quantità dipenderà dalle condizioni di tiraggio locale e dalla regolazione della ventola di tiraggio. La maggior parte della fuliggine verrà normalmente bruciata quando si apre completamente la valvola di tiraggio e il fuoco brucia vivacemente nel camino.

**Un suggerimento utile:** Per la normale pulizia, inumidire un pezzo di carta assorbente con acqua tiepida e aggiungere un po' di cenere presa dalla camera di combustione. Sfregare il pezzo di carta contro il vetro, quindi pulirlo con acqua pulita.

### Eliminazione della cenere

Jøtul F 600 possiede un ceneraio che rende più semplice rimuovere la cenere. Scuotere la cenere attraverso la grata nella piastra di base e quindi nel ceneraio. Utilizzare un guanto o la maniglia mobile, tenere la maniglia del ceneraio ed estrarre la cenere. Assicurarsi che il ceneraio non si riempia fino al punto di impedire alla cenere di scendere dalla grata.

**Assicurarsi che lo sportello del ceneraio sia ben chiuso quando la stufa è in funzione.**

È sempre meglio lasciare uno strato di cenere sul fondo della camera di combustione come strato protettivo. Vedere anche le istruzioni sullo smaltimento della cenere nella sezione Misure antincendio.

### Pulizia del camino ed eliminazione della fuliggine

L'utilizzo della stufa può causare depositi di fuliggine all'interno della stessa. La fuliggine è un buon isolante e riduce l'emissione di calore della stufa.

È necessaria una pulizia interna annuale per ottenere i migliori risultati dal prodotto. È consigliabile eseguire questa operazione assieme alla pulizia della cappa e della canna fumaria.

# ITALIANO

## Pulizia della canna fumaria verso la cappa

La pulizia della canna fumaria si esegue alzando la piastra superiore non fissata. Ciò consente un agevole accesso per le operazioni di pulizia. È possibile pulire passando dall'apposito sportello posto sulla canna fumaria o dallo sportello della stufa. In questo caso occorre prima rimuovere il parafiamma. Vedere la sezione: Riparazione.

## Controllo del camino

Jøtul consiglia di controllare personalmente e con attenzione il camino dopo averne eseguito la pulizia. Controllare che non vi siano crepe su tutte le aree di superficie visibili. Verificare che tutte le giunzioni siano ermetiche e che le guarnizioni siano posizionate correttamente. Qualsiasi guarnizione che presenti segni di usura e deformazione deve essere sostituita.

Pulire a fondo la scanalatura della guarnizione, aggiungere adesivo ceramico (acquistabile presso il rivenditore locale Jøtul) e premere la guarnizione nella posizione corretta. Il giunto si asciugherà rapidamente.

## Manutenzione esterna

Dopo diversi anni di utilizzo, i prodotti verniciati possono cambiare colore. Prima di applicare nuova vernice per camino Jøtul, è necessario pulire la superficie e spazzolare via le particelle residue.

I prodotti smaltati devono essere puliti solo con un panno asciutto. Non utilizzare acqua né sapone. Eventuali macchie possono essere rimosse con prodotti detersivi (prodotti per il forno e così via).

## Lunghezza, quantità e qualità della legna

Utilizzare ciocchi con una lunghezza massima di **55 cm**. I ciocchi devono essere collocati parallelamente alla parete posteriore della camera di combustione. L'emissione minima di calore di un camino Jøtul F 600 è di **3,5 kWh**, e la capacità nominale di **10,0 kWh**. Il requisito calcolato per l'emissione nominale di calore è di **4,0 kg** di legna di qualità ogni ora.

## Legna di qualità: Definizione di Jøtul

La legna di buona qualità deve presentare un grado di essiccazione tale che il contenuto di acqua sia pari a circa il 20-25%.

Per raggiungere tale livello, la legna deve essere tagliata nel tardo inverno o all'inizio della primavera. Deve essere poi tagliata e impilata in modo da assicurare un'adeguata ventilazione. Le cataste devono venire coperte per evitare che assorbano troppa acqua piovana. In autunno la legna dovrebbe essere tenuta al chiuso per poterla utilizzare durante l'inverno.

La quantità di energia ottenibile da 1 kg di legna varia molto poco. Il peso specifico dei differenti tipi di legname varia invece in misura considerevole. Ad esempio, il peso di un determinato volume di legno di betulla produce meno kWh rispetto alla medesima quantità di legno di quercia.

La quantità di energia contenuta in un 1 kg di legna di qualità è circa **3,8 kWh**. 1 kg di legname completamente essiccato (0 % di umidità) produce circa **5 kWh**, mentre del legname con un tasso di umidità del 60% produce soltanto circa **1,5 kWh/kg**.

## Riparazione

### Sostituzione delle piastre refrattarie

- Il camino è dotato di piastre refrattarie nelle parti laterali e nella parte posteriore. La piastra refrattaria dello sportello destro è fissata con una vite..
- Per rimuoverla, allentare la vite ed estrarre la piastra refrattaria.
- Per installarla seguire la medesima procedura.

### Sostituzione del parafiamma

- Il parafiamma consiste in 2 placche di acciaio situate in cima ai condotti che forniscono aria di riserva.
- Per rimuoverle, sollevare leggermente la parte centrale verso l'alto ed estrarle.
- Per installarle, ricollocare entrambe le piastre nella stessa maniera. Assicurarsi che siano fissate bene contro la parete di fondo.
- Posizionare poi la copertura isolante sopra le piastre del parafiamma.

## Attrezzatura facoltativa

### Condotto di collegamento per la ventilazione esterna - codice cat. 221032

Con l'aiuto di un condotto di collegamento per la ventilazione esterna e di tubo flessibile, è possibile convogliare all'elemento l'aria di combustione direttamente dall'esterno. In questo modo nella stufa sarà sempre presente una quantità di aria tale da permettere un'adeguata combustione.

## Inhaltsverzeichnis

### Behördliche Auflagen

Technische Daten des Jøtul F 600 .....	48
Allgemeine Sicherheitsbestimmungen .....	48
Brandverhütungsmaßnahmen .....	48

### Aufstellen des Jøtul F 600

Fundamente .....	48
Schornstein .....	48
Luftzirkulation .....	48
Zusammenbau vor der Aufstellung .....	49
Steuergeräte .....	49
Installation des Abzugsrohrs .....	49
Anschluß an den Schornstein .....	49

### Inbetriebnahme

Inbetriebnahme und täglicher Gebrauch .....	50
Inbetriebnahme .....	50
Täglicher Gebrauch .....	50
Heizen in der Übergangszeit .....	50

### Pflege

Reinigung des Sichtfensters .....	51
Entfernen der Asche .....	51
Reinigung des Kamins und Rußentfernung .....	51
Fegen des Abzugsrohres zum Kaminofen .....	51
Inspektion des Ofens .....	51
Pflege der Oberflächen .....	51
Länge, Menge und Qualität der Holzscheite .....	51
Jøtuls Definition von Qualitätsbrennholz .....	52

### Instandhaltung

Austausch der Brennerplatten .....	52
Austausch der Sperrplatte .....	52

### Optionale Zusatzausrüstung

Verbindungsrohr für die Aussenentlüftung .....	52
------------------------------------------------	----

Abbildungen - Zeichnungen .....	59
---------------------------------	----

## Behördliche Auflagen

Der Jøtul F 600 ist ein sauber brennender Kamin.

Das Typenschild (Geräteschild) befindet sich auf der Hitzeshild des Gerätes. Es besteht aus wärmebeständigem Material. Auf dem Typenschild sind folgende Angaben aufgelistet: Hersteller und Adresse, Typennummer, Herstellnummer, Nennwärmeleistung, Registriernummer, DIN-Norm-Nummer, Bauart und Sicherheitsabstände. Neben dem Typenschild befindet sich das Überwachungszeichen (Ü-Zeichen). Das Typenschild kann hinten auf dem U.S. Typenschild oder hinten auf dem eventuellen Hitzeschild befestigt werden.

### Bauarten von Kaminöfen

DIN 18891 unterscheidet Kaminöfen der Bauart 1 und 2. Kaminöfen der Bauart 1 haben eine selbstschliessende Feuerraumtür und dürfen an einen mehrfach belegten Schornstein angeschlossen werden. Aus Sicherheitsgründen muß die Feuerraumtür mit Ausnahme der Bedienung stets geschlossen sein. Kaminöfen der Bauart 1 dürfen ständig betrieben werden.

Kaminöfen der Bauart 2 müssen an einen eigenen Schornstein angeschlossen werden. Der Betrieb mit offenem Feuerraum ist nur unter Aufsicht statthaft. Kaminöfen der Bauart 2 dürfen nur 40 Stunden im Monat betrieben werden, d.h. z.B 8 Mal 5 Stunden.

**Die Aufstellung muß gemäß den behördlichen Auflagen und Bestimmungen des jeweiligen Landes erfolgen. Ziehen Sie immer die örtliche Baubehörde oder die entsprechende Behörde zu Rate, die für behördliche Auflagen und Bestimmungen des jeweiligen Bezirks verantwortlich ist. Ihr Vertragshändler wurde speziell wegen seiner Kenntnisse der behördlichen Auflagen ausgewählt und wird Ihnen behilflich sein, den Kamin sicher und in gesetzlich vorgeschriebener Weise aufzustellen.**

**Vorsicht!** Stellen Sie eine ausreichende Belüftung des Raumes sicher, in dem der Ofen aufgestellt werden soll.

**Eine unzureichende Belüftung verursacht die Entstehung von gefährlichen Rauchgase im Raum, welche zu Schläfrigkeit, Übelkeit und Krankheit führen können und extrem gefährlich ist.**

Es muß sichergestellt sein, daß der Schornstein den für den Ofen erforderlichen Abmessungen entspricht und die Anschlußelemente dicht mit dem Schornstein abschließen und ordnungsgemäß funktionieren. In abgeschlossene Räume eindringende Abluftgase stellen ein ernst zunehmendes Gesundheitsrisiko dar.

Anleitungen für Montage bzw. Aufstellung und zum Betrieb des Kamins sind dem Produkt beigelegt. Das Gerät darf nur dann in Betrieb genommen werden, wenn es geprüft und als betriebsbereit genehmigt wurde.

# DEUTSCH

## Technische Daten des Jøtul F 600:

Material:	Guß Eisen
Anstrich:	Schwarze Farbe, blau-schwarze und ozeangrüne Emaille
Heizmaterial:	Holz
Max. Holz Scheitlänge:	55 cm
Abzugssystem:	Ober- und Unterzug
Verbrennungssystem:	Sekundäre Verbrennung
Rohrstutzen:	Oben/Rückseite
Rohrabmessungen:	Durchmesser 150 mm
Einsetzbares Stahlrohr:	Ja
Gewicht, ca.:	200 kg
Sonderausstattung:	Wärmeabschirmung unten Wärmeabschirmung hinten

Produktabmessungen,  
Entfernungsangaben zu  
isolierten/nicht isolierten  
Wänden. Siehe **Abb. 1 und 2.**

## Allgemeine Sicherheitsbestimmungen

Anforderungen an die Brandschutzplatte: Sofern der Ofen auf einem Boden aus brennbarem Material aufgestellt werden soll, muß der gesamte Bodenbereich unter, sowie ca. **500 mm** vor, und am rechten Seite des Ofens, mit einer Brandschutzplatte aus nicht brennbarem Material ausgelegt sein. Die Brandschutzplatte muß sich seitlich min. 300 mm über die Feuerraumöffnung erstrecken. (Siehe Maßangaben in **Abb. 2**).

Der Ofen ist so isoliert, daß zwischen Brandschutzplatte und brennbaren Fußboden kein Isoliermaterial erforderlich ist.

**Abstand zu einer Brandschutzwand oder einer isolierten Wand:** Bei der örtlichen Baubehörde erhalten Sie Informationen zu Einschränkungen und Auflagen bei der Aufstellung.

Die Seitentür des Ofens darf bei der Aufstellung in einer Nische oder Ecke nicht genutzt werden.

**Nicht isoliertes Abzugsrohr:** Wenn nicht isolierte Abzugsrohre durch Böden oder Wände führen, schreiben die Dokumentation eine Schalung oder Steinmauerung vor, damit die Außenfläche des Rohres nicht weniger als **230 mm** vom brennbaren Material entfernt ist. Isolierte Abzugsrohre dürfen in einem anderen Abstand verlegt werden (vgl. die Sicherheitsdokumentation für das Abzugsrohr).

## Brandverhütungsmaßnahmen

Die Benutzung des offenen Kamins ist stets mit einer gewissen Gefahr verbunden. Deshalb sollten die folgenden Anweisungen unbedingt beachtet werden.

- Verwenden Sie immer einen Funkenfänger, sofern das Produkt mit geöffneter Tür genutzt werden soll.

- Es ist darauf zu achten, daß Möbel und andere brennbare Gegenstände nicht zu nahe am offenen Kamin stehen. Innerhalb eines Mindestsicherheitsabstandes von **800 mm** zum offenen Kamin hin dürfen sich keine Gegenstände befinden.
- Lassen Sie das Feuer einfach ausgehen. Löschen Sie das Kaminfeuer niemals mit Wasser. Dadurch kann der Kamin beschädigt werden.
- Der offene Kamin wird heiß und kann bei Berührung Verletzungen hervorrufen.
- Die Asche muß draußen an einem Ort entsorgt werden, an dem keine Feuergefahr mehr entstehen kann. Halten Sie sich an die behördlichen Bestimmungen.
- Für jeden Ofen sollte als Standard-Zubehör ein Behälter aus nicht brennbarem Material bereitstehen, in dem sich Ruß und Asche feuersicher aufbewahren lassen. Ruß und Asche müssen mindestens eine Woche lang in diesem Behälter gelagert werden, damit sichergestellt ist, daß auch die letzte Glut erloschen ist. Muß der Behälter früher entleert werden, ist der Inhalt erst mit reichlich Wasser zu vermischen.
- Ein Aufbewahren der Asche ist ebenfalls möglich. Asche ist ein hervorragender Dünger für Rosen und andere Pflanzen.

## Aufstellen des Jøtul F 600

**Hinweis!** Vor dem Aufstellen ist der Ofen auf Beschädigungen zu untersuchen.

**Der Kamin ist schwer!** Um ihn aufzustellen und in die richtige Position zu bringen, ist eine zweite Person erforderlich.

## Fundamente

Wenn der Jøtul F 600 auf einem Holzfußboden aufgestellt werden soll, muß sichergestellt sein, daß der Boden unter dem Ofen diese Traglast auch aufnehmen kann.

## Schornstein

Der Ofen kann an einen gemauerten oder vorgefertigten Schornstein oder an den Stahlschornstein von Jøtul angeschlossen werden. Siehe den entsprechenden Abschnitt. Der Schornstein muß einen Mindest-querschnitt von 177 cm<sup>2</sup> bzw. einen Durchmesser von 150 mm haben. Der Anschluß an den Schornstein muß gemäß den Einbauanweisungen des Schornstein-lieferanten erfolgen.

## Luftzirkulation

Die Benutzung eines offenen Kamins erfordert für den Raum, in dem der Kamin steht, eine reichliche Frischluftzufuhr. Wenn das Haus vollständig isoliert ist, muß der Raum mit einer besonderen Frischluftzufuhr versehen werden, z.B. durch einen separaten Luftkanal. In Räumen

mit offenen Kaminen sollten keine Lüftungseinrichtungen mit mechanischem Gebläse verwendet werden. Dies führt ggf. zu einer ungünstigen Druckverteilung, wodurch giftige Abgase in den Raum geblasen werden. Um dies zu vermeiden, kann über einen Adapter (Zusatzausstattung), der am Lufteinlaß des Ofens angebracht wird, direkt Außenluft zugeführt werden. Von dort führt ein flexibler Schlauch nach Außen. Die Anleitung zur Aufstellung sind der Zusatzausstattung beigelegt.

## Zusammenbau vor der Aufstellung

Der Ofen wird in einer Komplettverpackung geliefert. Außerdem enthält das Paket einen losen Handgriff für die Tür.

Die ovale Oberplatte ist während des Transports mit Schrauben befestigt. Lösen Sie die Schrauben der Oberplatte von unten und entfernen Sie sie. Dies erleichtert dem Schornsteinfeger die Reinigung von Kamin und Abzugsrohr.

Lösen Sie die oben befestigten Aschenlippen und montieren Sie sie. Die vordere Aschenlippe wird lose auf die Ofenplatte gelegt, während die seitliche Aschenlippe mit der Schraube an der Ofenplatte befestigt wird.

## Steuergeräte (Abb. 3)

Bei der Aufstellung des Kamins müssen immer die Steuergeräte überprüft werden. Diese sollten leichtgängig sein und einwandfrei arbeiten.

### Luftzufuhröffnung (A)

Linke Position = geschlossen.

Rechte Position = vollständig geöffnet.

### Türgriff (B)

Nach links = geöffnet. Nach rechts = geschlossen.

### Türgriff (C)

Nach rechts = geöffnet. Nach links = geschlossen.

### Aschentür (E)

Drehen Sie den Handgriff eine halbe Drehung entgegen dem Uhrzeigersinn. Ziehen Sie den Aschkasten mit einem Handschuh oder ähnlichem heraus.

**Hinweis! Entnehmen Sie Asche nur bei abgekühltem Ofen.**

## Installation des Abzugsrohrs

Der Kamin sollte zuerst probeweise montiert werden, bevor ein Teil der Wand am Schornstein herausgeschlagen wird. In **Abb. 2** sind die Abmessungen für einen Wanddurchschlag bei einer Wand aus entflammbar Werkstoff angegeben. Der Ofen wird mit einem Abzugsrohr von **150 mm** Durchmesser installiert. Dieser Durchmesser muß zulässig sein.

Der Rohrstützen von Jøtul F 600 befindet sich während des Transports in der Verbrennungskammer. Der Rohrstützen für das Abzugsrohr kann oben oder auf der Rückseite montiert werden. Die Befestigungsschrauben befinden sich in der Tüte mit den Schrauben.

- Das Abzugsrohr mit einem Durchmesser von 150 mm wird direkt in den Rohrstützen des Ofens gesteckt. Auf beiden Seiten des Kaminabzugs (**Abb. 4-A**) befindet sich eine Schraube. Befestigen Sie damit das Abzugsrohr.
- Markieren Sie die Stelle am Abzugsrohr, an der die Schrauben auf das Abzugsrohr stoßen, wenn das Rohr am Boden des Rohrstützens anliegt, und bohren Sie für die Schrauben ein 5,5 mm großes Loch in das Abzugsrohr.
- Dichten Sie den Übergang von Rohrstützen und Abzugsrohr mit Dichtung und Ofenkitt ab. Legen Sie die Dichtung um den unteren Bereich des Abzugsrohrs, und füllen Sie die Lücke mit Ofenkitt.
- Befestigen Sie das Abzugsrohr mit den Schrauben.

**Hinweis! Es ist wichtig, daß die Fugen vollständig abgedichtet sind.** Austretende Luft o. ä. kann die ordnungsgemäße Funktion des Kamins beeinträchtigen.

## Anschluß an den Schornstein

Bohren Sie ein Loch für das Abzugsrohr. Die Abmessungen vom Ofen zu Feuerwand/Schornstein entnehmen Sie den **Abb. 2**. Verwenden Sie beim Anschluß an einen Schornstein immer eine Schornsteinmanschette. Verwenden Sie beim Anschluß an einen Schornstein aus Betonelementen die vom Lieferanten empfohlene Schornsteinmanschette. Bevor Sie den offenen Kamin benutzen, lesen Sie in der Zusammenbau- und Gebrauchsanleitung des Lieferanten sorgfältig die Hinweise über den Ofenkitt und befolgen Sie diese.

Sorgen Sie dafür, daß das Abzugsrohr sich auf keinen Fall zum Schornstein nach unten neigt. Es sollte zumindest waagrecht, eher sogar einige Millimeter aufwärts verlaufen.

**Hinweis! Eine ordnungsgemäße und dichte Verbindung ist für eine einwandfreie Funktion des Kamins äußerst wichtig.**

Bitte beachten Sie, daß insbesondere flexible Rohrverbindungen wichtig sind. Dadurch wird eine mögliche Rißbildung der Rohre verhindert.

## Inbetriebnahme

### Inbetriebnahme und täglicher Gebrauch

Der Jøtul F 600 ist ein sauber brennender Kamin, der mit Hilfe einer zusätzlichen Verbrennungsluftzufuhr alle giftigen Gase und Partikel nachverbrennt. Eine ordnungsgemäße Benutzung des Systems ist wichtig.

Der Ofen ist mit bestimmten Funktionen ausgestattet, die im Abschnitt "Steuergeräte" beschrieben sind: Steuergeräte.

### Inbetriebnahme

Öffnen Sie die Luftzufuhröffnung, indem Sie die Zufuhrklappe ganz nach rechts (**Abb. 3-A**) schieben. Legen Sie etwas zerknülltes Zeitungspapier, Anzündholz und Brennholz in den offenen Kamin; entfachen Sie dann zuerst ein kleines Feuer. Legen Sie schrittweise weiteres Brennholz in die Feuerstelle und lassen Sie das Feuer einige Stunden mit lebhafter Flamme brennen. Lassen Sie das Feuer ausbrennen, und wiederholen Sie das Ganze.

**Hinweis! Wenn Sie den Ofen das erste Mal benutzen, kann es zur Geruchsbildung kommen.**

**Kamine mit Farbanstrich.** Wenn der Ofen zum ersten Mal verwendet wird, können sich streng riechende Dämpfe bilden, die aber nicht giftig sind. Sie sollten ein Fenster oder eine Tür öffnen, damit der Raum gründlich belüftet wird. Lassen Sie das Feuer bei starkem Luftzug brennen, bis auch die letzten Spuren von Dämpfen verschwunden und auch kein Rauch und keine Gerüche mehr vorhanden sind.

**Emaillierte Kamine:** An der Außenfläche des Ofens kann sich Kondenswasser bilden, wenn der Kamin die ersten Male in Betrieb ist. Das muß in jedem Fall weggewischt werden, um die Bildung bleibender Wasserflecken bei Erwärmung der Oberfläche zu vermeiden.

### Täglicher Gebrauch

Entfachen Sie das Feuer mit Hilfe von Zeitungspapier und etwas Anzündholz. Legen Sie zwei nicht zu große Holzscheite auf jede Seite der Feuerstelle. Schieben Sie etwas zusammengedrehtes Zeitungspapier zwischen die Scheite, legen Sie dann etwas Anzündholz in einem kreuzförmigen Muster darauf und zünden Sie das Feuer an. Legen Sie jetzt immer größere Holzscheite in das Feuer.

**Luftzufuhröffnung (Abb. 3-A).** Regulieren Sie die Luftzufuhr so, daß das Holz einwandfrei angezündet werden kann und sauber verbrennt. Prüfen Sie, ob die Nachverbrennung (Sekundärverbrennung) beginnt. Eine gelbliche, flackernde Flamme in der Luftkammer kennzeichnet diesen Vorgang am deutlichsten. Die gewünschte Hitzestufe regulieren Sie über die Verbrennungsgeschwindigkeit; stellen Sie dazu die Luftzufuhröffnung entsprechend ein.

Verwenden Sie stets Brennholz guter Qualität. Damit werden die besten Ergebnisse erzielt und der Kamin nicht beschädigt.

**Der Ofen darf niemals gefeuert werden mit:**

- Hausmüll, Plastiktüten usw.
- angestrichenem oder imprägniertem Holz (hochtoxisch)
- Spanplatten oder Laminatbretter
- Treibholz

*All das kann den Kamin beschädigen und belastet die Umwelt, insbesondere die Luft.*

**Hinweis!** Entfachen Sie ein Feuer niemals mit leicht entzündlichen Flüssigkeiten wie z. B. Benzin, Kerosin, Brennspritus o. ä. Es besteht Verletzungsgefahr; außerdem kann der Kamin beschädigt werden.

**Hinweis!** Überhitzungsgefahr: Der Ofen darf auf keinen Fall in einer Weise betrieben werden, die zu einer Überhitzung führt.

Eine Überhitzung liegt immer dann vor, wenn der Ofen mit Brennholz überladen wird bzw. die Luftzufuhröffnung vollständig geöffnet bleibt.

Der Lufteinzug am Schornstein darf 2,5 mmVs (25 Pa) nicht übersteigen. Ein sicheres Anzeichen für eine Überhitzung ist es, wenn Teile des Ofens bereits rotglühend sind. In diesem Fall müssen Sie sofort den Durchlaß für den Lufteinzug mit Hilfe der Luftöffnung verringern.

**Vorsicht!** Lassen Sie das Feuer solange brennen, bis nur noch glimmende Asche vorhanden ist, bevor Sie neues Brennholz auflegen.

### Heizen in der Übergangszeit

In der Übergangszeit, d.h. bei höheren Außen-temperaturen, kann es bei plötzlichem Temperaturanstieg zu Störungen des Schornsteinzuges kommen, so daß die heizgase nicht vollständig abgezogen werden. Die Feuerstätte ist dann mit geringeren Brennstoffmengen zu befüllen und bei grösserer Stellung des Primärluftschiebers/-reglers so zu betreiben, daß der vorhandene Brennstoff schneller (mit Flammen-entwicklung) abbrennt und dadurch der Schornsteinzug stabilisiert wird. Zur Vermeidung von Widerständen im Glutbett sollte die Asche öfter vorsichtig abgeschürt werden.

## Pflege

### Reinigung des Sichtfensters

Der Jøtul F 600 ist mit einem Oberzug (Luftreinigung) ausgerüstet. Durch die Luftzufuhröffnung gelangt die angesaugte Luft von oben an die Feuerstelle und reinigt das Sichtfenster entlang der Innenseite nach unten. Dieses System verbessert den Verbrennungsvorgang und reduziert die Rußablagerungen auf dem Sichtfenster.

Natürlich verbleibt je nach den örtlichen Luftzugverhältnissen und der Einstellung Luftzufuhröffnung immer noch etwas Ruß am Sichtfenster. Normalerweise verbrennt der Großteil der Rußschicht bei vollständig geöffneter Luftzufuhröffnung, und das Feuer brennt mit lebhafter Flamme.

**Nützlicher Hinweis!** Verwenden Sie zur einfachen Reinigung des Sichtfensters ein mit warmem Wasser angefeuchtetes Papiertuch, dem Sie etwas Asche aus der Verbrennungskammer beimengen. Reiben Sie mit dem Papiertuch über das Sichtfenster und waschen Sie anschließend mit klarem Wasser nach.

### Entfernen der Asche

Der Jøtul F 600 verfügt über einen Aschkasten, der das Entfernen der Asche vereinfacht. Kehren Sie die Asche durch den Rost in der Ofenplatte in den Aschkasten. Halten Sie den Griff des Aschenkastens mit einem Handschuh oder mit dem Handgriff fest, und bringen Sie die Asche weg. Achten Sie darauf, daß der Aschkasten nicht so hoch gefüllt wird, daß keine Asche mehr durch den Rost nach unten in den Kasten fallen kann.

Die Tür zum Aschkasten muß während des Ofenbetriebs fest geschlossen sein.

Sie sollten immer ein wenig Asche in der Verbrennungskammer als Schutzschicht für den Ofensockel lassen. Eine Erläuterung zum Umgang mit der Asche finden Sie unter "Brandverhütungsmaßnahmen".

### Reinigung des Kamins und Rußentfernung

An den Innenflächen des Ofens können sich bei Gebrauch Rußablagerungen bilden. Der Ruß wirkt wie ein Isolator und verringert daher die Wärmeabgabe des Ofens.

Einmal jährlich sollte das Kamininnere gereinigt werden, um die größtmögliche Wärmenutzung zu erhalten. Dabei ist es sinnvoll, Schornstein und Abzugsrohre gleich mit auszufegen.

### Fegen des Abzugsrohres zum Kamin

Zum Fegen der Abzugsrohre heben Sie die locker aufliegende ovale Oberplatte ab. So erhalten Sie einfachen Zugang zum Fegen. Das Fegen kann durch die Rohrluke im Abzugsrohr oder die Türöffnung des Kamins erfolgen. In diesem Fall muß zuerst die Sperrplatte herausgenommen werden. Siehe entsprechende Abschnitte unter: Instandhaltung.

### Inspektion des Ofens

Jøtul empfiehlt, daß Sie persönlich eine sorgfältige Inspektion des Ofens durchführen, nachdem er gereinigt bzw. ausgefegt wurde. Prüfen Sie alle sichtbaren Oberflächen auf Risse. Prüfen Sie auch, ob alle Verbindungen abgedichtet sind und alle Dichtungen richtig sitzen. Verschlossene oder verformte Dichtungen müssen ersetzt werden.

Reinigen Sie die Dichtnuten sorgfältig, tragen Sie Spezialkleber (erhältlich bei Ihrem Jøtul-Vertragshändler) auf und pressen Sie die Dichtung in ihren Sitz. Die Verbindungen trocknen schnell.

### Pflege der Oberflächen

*Bei lackierten Kaminen* kann sich der Farbton nach mehreren Jahren ändern. Bevor Sie einen neuen Jøtul-Ofenlack aufbringen, müssen Sie die Oberflächen sauber wischen und von losen Partikeln befreien.

*Emalliierte Kamine* dürfen nur mit einem sauberen, trockenen Tuch abgewischt werden. Verwenden Sie kein Wasser und keine Seife. Wasserflecken lassen sich mit Reinigungsmitteln (Ofenreiniger o. ä.) entfernen.

### Länge, Menge und Qualität der Holzscheite

Die verwendeten Holzscheite dürfen nicht länger als **55 cm** sein. Die Holzscheite müssen parallel zur Rückwand der Verbrennungskammer plaziert werden. **Die kleinste Wärmeabgabe** des Jøtul F 600 liegt bei **3,5 kWh**, seine **Nennkapazität** beträgt **10,0 kWh**. Um den Ofen bei Nennwärmeabgabe zu betreiben, sind ca. 4,0 kg Qualitätsbrennholz pro Stunde erforderlich.

# DEUTSCH

## Jøtuls Definition von Qualitätsbrennholz

Brennholz guter Qualität muß trocken sein, d.h. mit einem Wasseranteil von ca. 20-25 %.

Zu diesem Zweck sollte das Holz am Ende des Winters oder zu Beginn des Frühjahrs geschlagen werden. Es sollte anschließend gespalten und trocken (abgedeckt) an der Luft gelagert werden. Die Brennholzstapel sollten abgedeckt werden, um ein übermäßiges Eindringen von Regenwasser zu vermeiden. Im Herbst sollten die Holzscheite drinnen gelagert werden, um dann im Winter verfeuert zu werden.

Brennholz guter Qualität sind beispielsweise Scheite von Birken-, Buchen- und Eichenbäumen.

Die Energieausbeute von 1 kg Holz schwankt nur wenig. Dagegen schwankt das spezifische Gewicht (Trockengewicht) der verschiedenen Holzarten erheblich. Ein bestimmtes Volumen Birkenholz liefert z.B. weniger kWh als das gleiche Volumen Eichenholz, das ein höheres spezifisches Gewicht besitzt. Die Energieausbeute von 1 kg Qualitätsholz liegt bei etwa 3,8 kWh. 1 kg absolut trockenes Holz (0 % Feuchtigkeit) liefert ca. 5 kWh, während Holz mit 60 % Feuchtigkeitsgehalt dagegen nur etwa 1,5 kWh/kg liefert.

## Instandhaltung

### Austausch der Brennerplatten

- Der Ofen verfügt an den Seiten und auf der Rückseite über Brennerplatten. Die Brennerplatte an der rechten Tür ist durch eine Schraube befestigt.
- Lösen Sie die Schraube und nehmen Sie die Brennerplatten heraus.
- Gehen Sie beim Zusammenbau genauso vor.

### Austausch der Sperrplatte

- Die Sperrplatte besteht aus 2 gußeisernen Platten, die auf den Rohren für die sekundäre Luftzufuhr gelagert sind.
- Heben Sie die Platte in der Mitte ein wenig an, und nehmen Sie sie heraus.
- Bauen Sie die Platten beim Zusammenbau genauso wieder ein. Achten Sie darauf, daß sie eng an der Rückwand anliegen.
- Legen Sie anschließend die Isoliermatte auf die Sperrplatten.

## Optionale Zusatzausrüstung

### Verbindungsrohr für die Aussenentlüftung - Katalognr. 221032

Mit Hilfe eines Verbindungsrohres für die Aussenentlüftung und flexiblen Kaminrohren kann die Verbrennungsluftzufuhr direkt von außen mit dem Produkt verbunden werden. Auf diese Weise erhält der Produkt stets genügend Frischluft, die für eine saubere und vollständige Verbrennung erforderlich ist.

## Inhoudsopgave

### Wettelijke voorschriften

Technische gegevens van de Jøtul F 600 .....	54
Algemene veiligheidsmaatregelen .....	54
Maatregelen voor brandpreventie .....	54

### Plaatsing van de Jøtul F 600

Vloer .....	55
Luchtcirculatie .....	55
Montage vóór plaatsing .....	55
Controle van de functies .....	55
Plaatsing van de kachelpijp .....	55
Schoorsteenaansluiting .....	55

### Gebruiksaanwijzing

Eerste keer stoken en dagelijks gebruik .....	56
Eerste keer stoken .....	56
Dagelijks gebruik .....	56

### Onderhoud

Glas reinigen .....	57
As verwijderen .....	57
Reinigen en roet verwijderen .....	57
Kachelpijpen naar de schoorsteen vegen .....	57
Haard inspecteren .....	57
Onderhoud buitenkant .....	57
Lengte, aantal en kwaliteit van houtblokken .....	58
Jøtuls definitie van goed brandhout .....	58

### Groot onderhoud

Stookplaten vervangen .....	58
Smoorplaat vervangen .....	58

### Optionele apparatuur

Aansluitpijp voor buitenventilatie .....	58
------------------------------------------	----

Figuren - tekeningen .....	59
----------------------------	----

## Wettelijke voorschriften

### Algemene informatie

De Jøtul F 600 toestel is gekeurd volgens de VHR Beoordelingsrichtlijn.

Installatie- en bedieningsvoorschrift zijn bij het product meegeleverd en dienen aangehouden te worden.

### Regelgeving en milieu- aspecten

Voordat het toestel geplaatst wordt moet gecontroleerd worden of de opstelplaats en schoorsteen aan de lokaal geldende bouwverordeningen en het Bouwbesluit voldoen. Voorkom overlast naar Uw omgeving; stook niet bij mist of windstil weer. U stookt goed als de rook wit of kleurloos is. Gebruik de juiste brandstof; zie verderop in de instructie.

### Controle voor de installatie

Bij plaatsing dient rekening gehouden te worden met de afstanden tot brandbare vloeren en wanden en het stralingsgebied rondom het toestel; zie verderop in de instructie.

Zorg ook voor voldoende ventilatie van de opstellingsruimte; minimale ventilatieopening (vrije doorlaat) van 6,2 x B (belasting toestel in kW) in cm<sup>2</sup> (zie ook Bouwbesluit).

Gebruik als afvoermateriaal Prefab roestvaststalen of keramische kanalen met een Keurmerk volgens KOMO of NEN 6062.

Voor de installatie dient het schoorsteenkanaal gecontroleerd en zonodig schoongemaakt te worden.

Veeg het kanaal 2x per jaar, 1x halverwege en 1x aan het eind van het seizoen.

Het typeplaatje bevindt zich op het hitteschild en is gemaakt van hittebestendig materiaal. Op het typeplaatje staat de volgende informatie: producent en adres, modelnummer, productienummer, vermogen, registratienummer (na toewijzing), model en veiligheidsmaatregelen. Het keurmerk bevindt zich naast het typeplaatje.

**De plaatsing van een haard dient aan de wettelijke voorschriften en bepalingen van het desbetreffende land te voldoen. Vraag uw plaatselijke dienst voor bouwtoezicht of een andere verantwoordelijke instantie welke voorschriften en bepalingen in uw omgeving van kracht zijn. De door ons geselecteerde dealers zijn op de hoogte van de ter plaatse geldende bepalingen. Zij kunnen u vertellen hoe u de haard veilig en volgens de wettelijke voorschriften kunt installeren.**

**Waarschuwing!** Zorg voor voldoende ventilatie in de ruimte waar de haard wordt geplaatst.

**Onvoldoende ventilatie kan tot zuurstofgebrek in de ruimte leiden. Dit kan slaperigheid en misselijkheid veroorzaken en is zeer gevaarlijk.**

# NEDERLANDS

Het is van belang ervoor te zorgen dat de schoorsteen de juiste afmetingen heeft voor de haard en dat de verbinding met de schoorsteen luchtdicht is en goed functioneert. Rookgas dat in afgesloten ruimten binnendringt, kan ernstige schade aan de gezondheid toebrengen.

Instructies voor montage, plaatsing en gebruik worden met het product meegeleverd. U kunt de geplaatste haard pas gebruiken als deze is geïnspecteerd en goedgekeurd.

## Technische gegevens van de Jøtul F 600:

Materiaal:	Gietijzer
Afwerking:	Zwarte, blauwzwarte en oceaangroene email
Brandstof:	Hout
Max. lengte van blokken:	55 cm
Ontluchtingssysteem:	Bovenste en onderste roosters
Verbrandingssysteem:	Secundaire verbranding.
Schoorsteenaansluiting:	Boven-/achterkant
Afmeting rookkanaal:	150 mm doorsnee
Kan stalen pijp worden toegepast:	Ja
Gewicht (ongeveer):	200 kg
Optionele accessoires:	Hitteschild onder hitteschild achter

Afmetingen product, afstanden tot afgeschermd/niet afgeschermd wand zie **afbeeldingen 1 en 2**.

## Algemene veiligheidsmaatregelen

**De vloerplaat moet voldoen aan het volgende:** Wanneer u de haard op een vloer van brandbaar materiaal wilt plaatsen, moet u de hele vloer onder de haard en minimaal 500 mm vóór de haard en rechts van de haard met een plaat van niet-brandbaar materiaal afdekken. De afmetingen van de plaat zijn afhankelijk van de ter plaatse geldende voorschriften en bepalingen, en wij adviseren u vóór plaatsing contact op te nemen met uw Jøtul-dealer. (Zie de maten in **afbeelding 2**).

**Afstand tot muur en vloer van brandbaar materiaal:** De haard is getest bij gebruik van een optoneel hitteschild, en bij afstanden tot een muur van brandbaar materiaal zoals in afbeeldingen 2 is weergegeven.

*Als het product in een nis of een hoek is geplaatst, mag de zijdeur van de haard niet worden gebruikt.*

**Niet-geïsoleerde kachelpijp:** Wanneer niet-geïsoleerde kachelpijpen door vloeren of muren worden geleid, moet de opening van steen of metselwerk zijn gemaakt en moet de buitenwand van de pijp minimaal 230 mm van brandbare materialen verwijderd blijven. Voor geïsoleerde kachelpijpen kan een andere afstand gelden. Raadpleeg zo nodig de brandtechnische productdocumentatie voor informatie over de kachelpijp.

## Maatregelen voor brandpreventie

**Elk gebruik van de haard kan een bepaald risico met zich brengen.** Neem daarom de volgende instructies nauwkeurig in acht:

- Gebruik altijd een vonkenvanger als het product met geopende deur wordt gebruikt.
- Zorg ervoor dat meubels of andere brandbare materialen niet te dicht bij de haard staan. De afstand tot de voorkant van de haard moet ten minste 800 mm bedragen.
- Laat het vuur vanzelf uitgaan. Blus het nooit met water, omdat dit de haard kan beschadigen.
- De haard wordt heet tijdens het gebruik en kan bij aanraking brandwonden veroorzaken.
- De as moet naar buiten worden afgevoerd of worden weggegooid op een plek waar geen brandgevaar bestaat. Volg de plaatselijke voorschriften op.
- Elke haard moet zijn voorzien van een opslagbak van onbrandbaar materiaal als standaardaccessoire voor de afvoer van roet en as. Roet en as moeten minstens één week in deze bak blijven liggen om er zeker van te zijn dat de laatste smeulende resten zijn gedoofd. Wanneer u de opslagbak eerder moet legen, giet dan voldoende water in de bak voor vermenging met de as.
- U kunt de as ook bewaren. As is uitstekende mest voor rozen en andere planten.

## Plaatsing van de Jøtul F 600

**Opmerking!** Controleer vóór het installeren of de haard geen transportschade heeft opgelopen. Het product is zwaar! Zorg voor hulp bij het neerzetten en installeren van de haard.

### Vloer

Als de Jøtul F 600 op een houten vloer wordt geplaatst, zorg er dan voor dat het draagvermogen van de vloer voldoende is voor de haard.

### Schoorsteen

De haard kan worden aangesloten op een gemetselde schoorsteen, een geprefabriceerd element of een stalen schoorsteen van Jøtul. Zie het afzonderlijke gedeelte.

De dwarsdoorsnede van de schoorsteen moet minstens 177 cm<sup>2</sup> bedragen. (Dat komt overeen met een diameter van 150 mm). De aansluiting op de schoorsteen moet voldoen aan de installatievoorschriften van de schoorsteenleverancier.

### Luchtcirculatie

De ruimte waarin een haard wordt gebruikt, moet voldoende toevoer van frisse lucht krijgen. Als het huis tochtvrij is, moet via ventilatieopeningen extra frisse lucht naar de ruimte worden toegevoerd. Gebruik geen mechanische ventilatoren in een ruimte met een haard. Deze kunnen negatieve druk veroorzaken waardoor giftige gassen in de ruimte kunnen komen. Om dit te vermijden kunt u buitenlucht rechtstreeks naar de haard toevoeren door middel van een adapter (optionele eenheid) die op de luchtinlaat van de haard wordt gemonteerd. Daaraan wordt een flexibele slang bevestigd die naar de buitenlucht wordt geleid. De installatie-instructies worden bij de adapter geleverd.

### Montage vóór plaatsing

De haard wordt in één pakket afgeleverd. Daarin bevindt zich een los handvat voor de deur.

De ovale afdekplaat is voor het transport met schroeven bevestigd. Verwijder deze schroeven aan de onderzijde van de afdekplaat en laat deze los liggen. Dat vergemakkelijkt het schoorsteenvegen wanneer de haard en de kachelpijp moeten worden gereinigd.

Verwijder de asranden, die aan de bovenkant zijn bevestigd, en begin met de installatie hiervan. De asrand aan de voorkant wordt losjes bovenop de grondplaat geplaatst, terwijl die aan de zijkant wordt vastgezet met de schroef die is bevestigd aan de grondplaat.

## Controle van de functies (afbeelding 3)

Als de haard op zijn plaats staat, controleer dan altijd de bedieningsfuncties. Deze moeten gemakkelijk beweegbaar zijn en naar behoren functioneren.

### Stookopening (A)

Links = dicht. Rechts = volledig geopend.

### Deurklink (B)

Naar links is geopend. Naar rechts is gesloten.

### Deurklink (C)

Naar rechts is geopend. Naar links is gesloten.

### Asklep (E)

Opent u de lade door de handvat een halve cirkel linksom te draaien. Gebruik handschoenen of iets dergelijks en til de aslade omhoog.

**Opmerking!** Verwijder de as alleen als de haard is afgekoeld.

## Plaatsing van de kachelpijp

Het is raadzaam een proefmontage uit te voeren voordat u een gat in de schoorsteen maakt. Zie **afbeelding 2** voor afmetingen tot de tot muur van brandbaar materiaal. De haard wordt geïnstalleerd met een kachelpijp van 150 mm doorsnee. De pijp moet een voorgeschreven dikte hebben.

**De kachelpijp van de Jøtul F 600 wordt tijdens het transport in de stookplaats bewaard. U kunt kiezen tussen de schoorsteenuitgang aan de bovenzijde of de achterzijde. De schroeven voor bevestiging bevinden zich in de zak met schroeven.**

- Kachelpijpen met 150 mm doorsnee worden direct op de schoorsteenuitgang van de haard geplaatst. Aan beide zijden van de schoorsteenuitgang bevindt zich een schroef (afbeelding 4-A). Zet de kachelpijp daarmee vast.
- Markeer de plek op de kachelpijp waar de schroef komt wanneer de pijp onder in de schoorsteenuitgang zit, en boor in de kachelpijp een gat van 5,5 mm voor de schroef.
- Sluit de kachelpijp met pakking en cement luchtdicht aan op de schoorsteenuitgang. Plaats de pakking rondom het onderste gedeelte van de kachelpijp en vul het gat met cement.
- Zet de kachelpijp met schroeven vast.

**Opmerking!** Het is van belang dat de verbinding volledig luchtdicht wordt afgesloten.

Lekkage van lucht en dergelijke kan de goede werking van de haard belemmeren.

## Schoorsteenaansluiting

Boor een gat voor de kachelpijp. In afbeeldingen 2 is de afstand tussen de haard en de brandmuur of schoorsteen aangegeven. Gebruik altijd een schoorsteenkraag bij de aansluiting op de schoorsteen. Gebruik de door de leverancier aanbevolen schoorsteenkraag bij het aansluiten op een geprefabriceerd element. Volg de instructies voor montage en gebruik van de leverancier nauwkeurig op in verband met mortel/kachelcement voordat u de haard gaat gebruiken.

# NEDERLANDS

Zorg ervoor dat de kachelpijp niet scheef staat ten opzichte van de schoorsteen. Deze moet in elk geval horizontaal zijn en liefst een helling hebben van enkele millimeters.

**Opmerking! Een juiste en luchtdichte aansluiting is van groot belang voor het goed functioneren van de haard.**

Het is van bijzonder belang dat de aansluitingen enigszins flexibel zijn. Dit voorkomt het ontstaan van scheurtjes als de vloer enigszins zou gaan doorzakken.

## Gebruiksaanwijzing

### Eerste keer stoken en dagelijks gebruik

De Jøtul F 600 is een haard met schone verbranding, die door middel van een luchtkamer voor naverbranding van eventuele giftige gassen en deeltjes zorgt. Het is belangrijk dat het systeem op de juiste wijze wordt gebruikt.

De haard is voorzien van bedieningselementen zoals beschreven in het hoofdstuk: Bediening van de functies.

### Eerste keer stoken

Maak de vulklep volledig open door deze helemaal naar rechts te draaien (**afbeelding 3-A**). Leg een paar proppen krantenpapier, wat aanmaakhout en brandhout in de kachel en maak een klein vuur. Voeg geleidelijk meer brandhout toe en laat het vuur een paar uur flink branden. Laat het vuur doven en steek de haard nogmaals aan.

**Opmerking! Geuren wanneer u de haard voor het eerst gebruikt.**

*Geverfde haarden:* Wanneer u de haard voor het eerst gebruikt, kan irriterend gas vrijkomen, dat onaangenaam kan ruiken. Dit gas is niet giftig, maar het is beter om een raam of een deur in de ruimte te openen om te zorgen voor extra ventilatie. Stook het vuur flink op totdat alle sporen van gas zijn verdwenen en geen rook of geuren meer zijn waar te nemen.

*Geëmailleerde producten:* De eerste paar keren dat de haard wordt gebruikt, kan condensatievorming op de haard plaatsvinden. Veeg dit weg om vlekken op de haard te voorkomen als het oppervlak warm wordt.

### Dagelijks gebruik

Gebruik krantenpapier en enkele aanmaakhoutjes om de haard aan te steken. Leg twee middelgrote blokken hout aan weerszijden van de grondplaat. Schuif enkele proppen krantenpapier (of berkenschors) tussen de blokken, leg er enkele aanmaakhoutjes kriskras bovenop en steek het papier aan. Gebruik geleidelijk aan grotere blokken.

Vulopening (**afbeelding 3-A**). Zet deze vast wanneer het hout is aangestoken en goed brandt. Controleer of er naverbranding (secundaire verbranding) plaatsvindt. Er flikkeren dan gele vlammen in de luchtkamer. Stel vervolgens de verbranding in op het gewenste verwarmingsniveau door de vulopening aan te passen.

Gebruik altijd goed brandhout. Dat geeft de beste resultaten en is niet schadelijk voor de haard.

## Verbrand nooit de volgende materialen in de haard:

- huishoudelijk afval, plastic tassen enzovoort.
- geverfd of geïmpregneerd hout (zeer giftig)
- spaanplaat of laminaat
- drijfhout

*Verbranding van deze stoffen kan schadelijk zijn voor de haard en het milieu.*

**Opmerking! Gebruik nooit benzine, petroleum, brandspiritus of soortgelijke brandbare vloeistoffen om het vuur aan te maken. Hierdoor kunt u letsel oplopen of kan de haard worden beschadigd.**

*Opmerking! Waarschuwing voor oververhitting: voorkom te allen tijde dat de haard oververhit raakt.*

Oververhitting treedt op als de haard te veel brandhout bevat en/of de vulopening volledig open is.

*De luchtstroom in de schoorsteen mag nooit groter zijn dan 2,5 mmVs (25 Pa).* Als de haard ergens rood gloeit, betekent dit dat deze oververhit is. Als dat gebeurt, dient u de ventilatieopening onmiddellijk te sluiten.

**Waarschuwing! Wacht tot het vuur smeult voordat u meer brandhout toevoegt.**

## Onderhoud

### Glas reinigen

De Jøtul F 600 heeft een luchttoevoer bovenin (stromende lucht). Lucht wordt aangezogen door de luchttoevoer boven de haard en stroomt langs de binnenkant van het glas naar beneden. Voordeel van dit systeem is, dat de verbranding wordt verbeterd en dat de roetaanslag op het glas wordt beperkt.

Toch zal zich altijd wel roet op het glas ophopen. De hoeveelheid is afhankelijk van de luchtstroom ter plaatse en de stand van de vulklep. De roetlaag wordt gewoonlijk grotendeels weggebrand wanneer de vulklep helemaal open staat en de haard flink brandt.

**Goed advies!** Maak voor een gewone schoonmaakbeurt een papieren handdoek nat met warm water en voeg er wat as uit de stookplaats aan toe. Wrijf met het papier over het glas en neem het glas daarna af met schoon water.

### As verwijderen

De Jøtul F 600 is voorzien van een aslade, waarmee u de as eenvoudig kunt verwijderen.

Schraap de as door het rooster van de grondplaat in de aslade. Gebruik een handschoen of de losse hendel, pak de hendel van de aslade beet en verwijder de as. Zorg dat de aslade niet zo vol raakt dat de as niet meer door het rooster in de aslade kan komen.

*Zorg dat de klep van de aslade goed gesloten is wanneer de haard wordt gebruikt.*

Het is beter om altijd een laagje as in de stookplaats achter te laten ter bescherming van de grondplaat van de haard. Zie ook het gedeelte onder **Maatregelen voor brandpreventie** voor het omgaan met asresten.

## Reinigen en roet verwijderen

Tijdens gebruik kan zich roet afzetten op de binnenwanden van de haard. Roet werkt isolerend en kan daardoor de warmteafgifte van de haard verminderen.

Een jaarlijkse schoonmaakbeurt is nodig voor een optimale warmteafgifte van het product. U kunt dit bijvoorbeeld doen als de schoorsteen en kachelpijp worden geveegd.

## Kachelpijpen naar de Schoorsteen vegen

Voor het vegen van de kachelpijp tilt u de losse ovale afdekplaat op. Dat biedt een gemakkelijke toegang voor het vegen. U kunt vegen via het veegluik in de kachelpijp of via de vulklep van het product. In het laatste geval moet eerst de smoorplaat worden verwijderd. Zie het gedeelte onder: Groot onderhoud.

## Haard inspecteren

Jøtul raadt u aan om na het reinigen/vegen zelf een grondige inspectie van de haard uit te voeren. Controleer alle zichtbare oppervlakken op scheuren. Controleer ook of de deur- en glasafdichtingen luchtdicht afsluiten en of de pakkingen nog op hun plaats zitten. Pakkingen die sporen van slijtage of vervorming vertonen, moeten worden vervangen.

Maak de pakkingsgroeven grondig schoon, breng keramische lijm aan (te verkrijgen bij uw Jøtul-dealer) en druk de pakking goed in de groef. De lijm heeft een korte droogtijd.

## Onderhoud buitenkant

Bij haarden met een laklaag kan na een paar jaar verkleuring optreden. Voordat u een nieuwe laag Jøtul-haardverf aanbrengt, moet u het oppervlak worden reinigen en alle losse deeltjes wegvegen.

Geëmailleerde haarden moet u alleen met een schone, droge doek afnemen. Gebruik geen water en zeep. Eventuele vlekken kunt u met een vloeibaar reinigingsmiddel verwijderen (zoals een ovenreiniger).

# NEDERLANDS

## Lengte, aantal en kwaliteit van houtblokken

De blokken mogen maximaal **55 cm** lang zijn. Leg de blokken parallel aan de achterwand van de verbrandingskamer. De warmteafgifte van een Jøtul F 600 bedraagt **minimaal 3,5 kWh** en de **nominale capaciteit 10,0 kWh**. Uit berekeningen is gebleken dat voor de nominale warmteafgifte 4,0 kg goed brandhout per uur nodig is.

## Jøtuls definitie van goed brandhout

**Goed brandhout moet droog zijn, dat wil zeggen dat het hout ongeveer 20 à 25% water mag bevatten.**

Dit bereikt u door het hout uiterlijk aan het einde van de winter of vroeg in het voorjaar te kappen. Daarna moet het worden gespleten en opgestapeld om het goed te drogen. De stapels moeten worden afgedekt om opname van regenwater te voorkomen. Haal de blokken hout in de herfst naar binnen voor gebruik tijdens het stookseizoen.

Met goed brandhout bedoelen we de bekende houtsoorten, zoals berken-, beuken- en eikenhout.

De hoeveelheid energie die 1 kg hout kan leveren, varieert niet veel. Het soortelijk gewicht van de verschillende houtsoorten verschilt daarentegen aanzienlijk. Zo levert een bepaalde hoeveelheid berkenhout minder kWh op dan dezelfde hoeveelheid eikenhout, dat een hoger soortelijk gewicht heeft.

De hoeveelheid energie van 1 kg goed brandhout bedraagt ongeveer 3,8 kWh. 1 kg volledig droog hout (0% vocht) levert ongeveer 5 kWh op, terwijl hout met 60% vocht slechts 1,5 kWh per kg oplevert.

## Groot onderhoud

### Stookplaten vervangen

- De haard heeft branderplaten aan de zijwanden en aan de achterzijde. De branderplaat op de rechterdeur is bevestigd met een schroef.
- Draai de schroef los en verwijder de branderplaten.
- Volg dezelfde procedure om de platen opnieuw te installeren.

### Smoorplaat vervangen

- De smoorplaat bestaat uit twee gietijzeren platen en rust boven op de pijpen die secundaire lucht toevoeren.
- Til de smoorplaten in het midden een klein stukje omhoog en verwijder ze.
- Volg dezelfde procedure om beide platen opnieuw te bevestigen. Zorg dat ze vlak tegen de achterwand worden bevestigd.
- Leg daarna de isolerende deken bovenop de smoorplaten.

## Optionele apparatuur

### Aansluitpijp voor buitenventilatie bestelnr. 221032

Met de hulp van een aansluitpijp voor buitenventilatie en flexibele slange is rechtstreekse toevoer van verbrandingslucht van buitenaf mogelijk. Op deze wijze wordt er altijd voldoende lucht aangevoerd in de produkt om voor een schone verbranding te zorgen.

Fig.1a

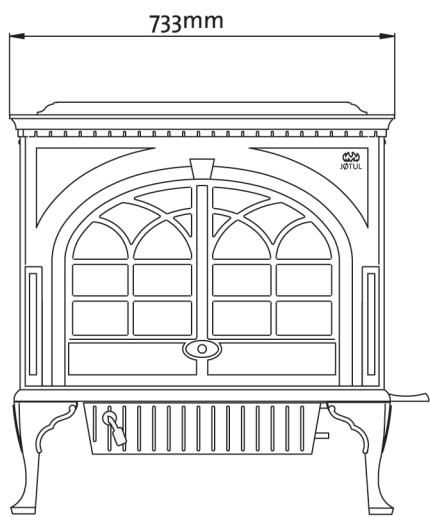

Fig. 2

Measurements according to VHR (with optional heatshield)

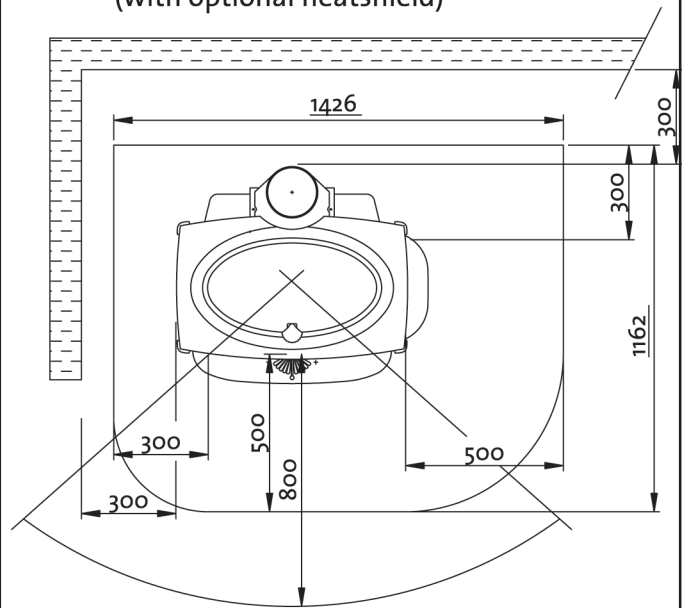

Fig.1b

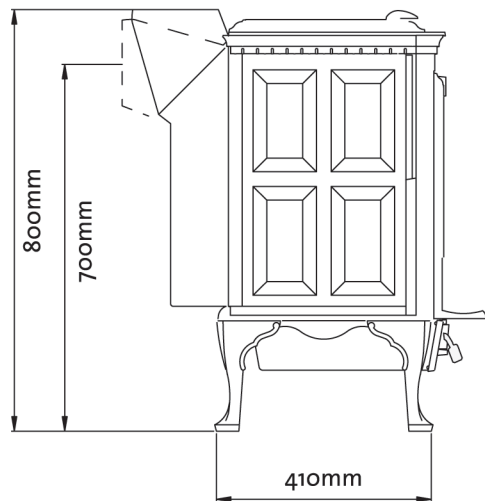

Fig. 3

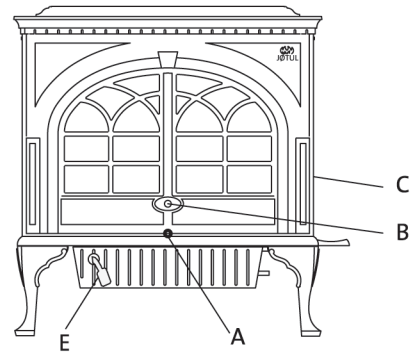

Fig.1c

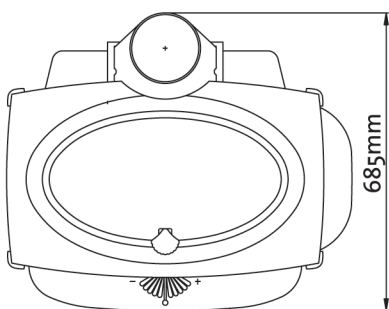
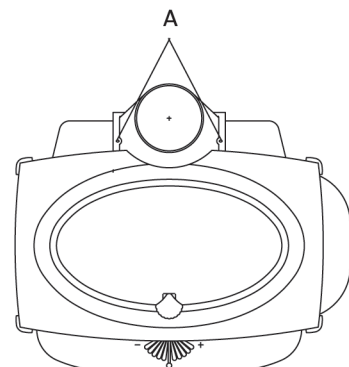

Fig.4



Jøtul arbeider kontinuerlig for om mulig å forbedre sine produkter, og vi forbeholder oss retten til å endre spesifikasjoner, farger og utstyr uten nærmere kunngjøring.

Jøtul bemüht sich ständig um die Verbesserung seiner Produkte, deshalb können Spezifikationen, Farben und Zubehör von den Abbildungen und den Beschreibungen in der Broschüre abweichen.

Jøtul pursue a policy of constant product development. Products supplied may therefore differ in specification, colour and type of accessories from those illustrated and described in the brochure.

Jøtul vise sans cesse à améliorer ses produits. C'est pourquoi, il se réserve le droit de modifier les spécifications, couleurs et équipements sans avis préalable.

#### **Kvalitet**

Jøtul AS arbeider etter et kvalitetssikringssystem basert på NS-EN ISO 9001 for utvikling, produksjon og salg av ildsteder. Vår kvalitetspolitikk skal gi kundene den trygghet og kvalitetsopplevelse som Jøtul har stått for siden bedriftens historie startet i 1853.

#### **Qualität**

Jøtul AS hat ein Qualitätssicherungssystem, das sich bei Entwicklung, Produktion und Verkauf von Öfen und Kaminen nach NS-EN ISO 9001 richtet. Diese Qualitätspolitik vermittelt unseren Kunden ein Gefühl von Sicherheit und Qualität, für das Jøtul mit seiner langjährigen Erfahrung seit der Firmengründung im Jahre 1853 steht.

#### **Quality**

Jøtul AS has a quality system that conforms to NS-EN ISO 9001 for product development, manufacturing, and distribution of stoves and fireplaces. This policy gives our customers quality and safety piece of mind as a result of Jøtul's vast experience dating back to when the company first started in 1853.

#### **Qualité**

Le système de contrôle de la qualité de Jøtul AS est conforme à la norme NS-EN ISO 9001 relative à la conception, à la fabrication et à la distribution de poêles, foyers et inserts. Cette politique nous permet d'offrir à nos clients une qualité et une sécurité reposant sur la vaste expérience accumulée par Jøtul depuis sa création en 1853.

Dette ildstedet er kontrollert av:  
Dieses Produkt ist geprüft von:  
This product has been controlled by:  
Ce produit a été contrôlé par :



Jøtul AS,  
P.o. box 1411  
N-1602 Fredrikstad,  
Norway

\_\_\_\_\_ Date: \_\_\_\_\_

\_\_\_\_\_ Sign: \_\_\_\_\_