

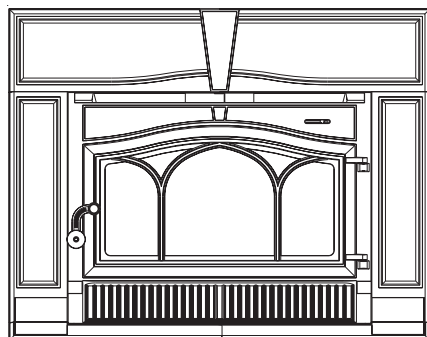

**Jøtul C 550 Rockland
Fireplace Insert**



Jøtul C 550 Rockland Fireplace Insert

Installation and Operating Instructions
for the United States & Canada



Keep these instructions for future reference.

NOTICE:
YOU SHOULD CONSULT THE AUTHORITY HAVING JURISDICTION IN YOUR LOCALE (SUCH AS MUNICIPAL BUILDING DEPARTMENT, FIRE DEPARTMENT, FIRE PREVENTION BUREAU, ETC.) BEFORE INSTALLATION TO DETERMINE THE NEED TO OBTAIN A PERMIT.



We suggest that our woodburning hearth products be installed and serviced by professionals who are certified in the U.S. by the National Fireplace Institute® (NFI) as NFI Woodburning Specialists or who are certified in Canada by Wood Energy Technical Training (WETT).



Table of Contents

Standards and Safety Notices

Standards / Codes 4
 Safety Notices 5
 Preparation 5
 Unpacking the Firebox 5

Specifications

Jøtul C 550 Rockland Fireplace Insert 6

Installation

Masonry Fireplace Requirements 7
 Factory-built Fireplace Requirements 7
 Chimney Height 7
 Hearth Protection 8
 Clearance to Combustibles 9
 Chimney Connection 10
 Firebox Installation 12
 Surround Assembly 13

Operation

Wood Fuel 14
 Air Control 14
 Starting / Maintaining the Fire 15
 Formation of Creosote 15
 Blower 16

Maintenance

Ash Removal 17
 Glass Care 17
 General Maintenance 18
 Gaskets 18

Illustrated Parts Breakdown

Exploded View 20
 Parts Listing 21

Appendix A

Alternate Hearth Protection 22
 Leg Leveler Installation 22
 Door Knob Assembly 23

For Your Records...

Record the following information to help your dealer determine what you will need should your fireplace ever require parts or service. The serial number and manufacturing date are located on the permanent label on the back of the firebox. You may also wish to attach your sales receipt to this manual for future reference.

Model: Jøtul C 550

Installation and Operation Instructions for USA/Canada *Installation et fonctionnement pour Canada*

SAFETY NOTICE: IF THIS SOLID FUEL ROOM HEATER IS NOT PROPERLY INSTALLED, A HOUSE FIRE MAY RESULT. FOR YOUR SAFETY, FOLLOW THE INSTALLATION DIRECTIONS. CONTACT LOCAL BUILDING OR FIRE OFFICIALS ABOUT RESTRICTIONS AND INSTALLATION INSPECTION REQUIREMENTS IN YOUR AREA. SAVE THESE INSTRUCTIONS FOR FUTURE REFERENCE.

Avis de sécurité: Une installation non appropriée de ce poêle de chauffage risque de provoquer un incendie. Assurez votre sécurité en respectant les directives d'installation suivantes. Consultez les autorités locales du bâtiment ou de la prévention des incendies au sujet des restrictions et exigences relatives aux inspections d'installations dans votre région.

*Tested and listed by ITS, Intertek Testing Services, Middleton, Wisconsin.
Tested to U.S. Standards: ANSI/UL 1482, Canadian Standards: CAN/ULC-S627-M93*



Standards

The Jøtul C 550 Fireplace Insert has been tested and listed to: U.S: ANSI/UL 1482
Canada: CAN/ULC-S628-93

Tests performed by:
Intertek Testing Services, Middleton, WI

Manufactured and distributed by:
Jøtul North America
55 Hutcherson Dr.
Gorham, ME 04036

N.Y.C. Dept of Buildings MEA 429-07-E

This heater meets the U.S. Environment Protection Agency's Phase II emissions limits for wood heaters manufactured and sold after July 1, 1990.

This appliance is not approved for use in mobile homes.

This appliance is listed to burn wood only. Do not burn other fuels.

Read this manual before you install and use your fireplace insert.

Save these instructions and make them available to anyone using or servicing the fireplace insert.

Check Building Codes

When installing, operating and maintaining your Jøtul C 550 Fireplace Insert, follow the guidelines presented in these instructions, and make them available to anyone using or servicing the stove.

Your city, town, county or province may require a building permit to install a solid fuel burning appliance.

In the U.S., guidelines established by UL 1777, the National Fire Protection Association's Code, NFPA 211, *Standards for Chimneys, Fireplaces, Vents and Solid Fuel Burning Appliances*, or similar regulations, may apply to the installation of a solid fuel burning appliance in your area. For further information on using your heater safely, obtain a copy of the NFPA publication "Using Coal and Wood Stoves Safely," NFPA No. HS-8-1974, available from NFPA

470 Atlantic Ave.
Boston, MA 02210.

In Canada, the guidelines are established by ULC-S635, and the CSA Standard, CAN/CSA-B365-M93, *Installation Code for Solid-Fuel-Burning Appliances and Equipment*.

Always consult your local building inspector or authority having jurisdiction to determine what regulations apply in your area.

Safety Notices

- **BURN SOLID WOOD FUEL ONLY**
- **DO NOT USE CHEMICALS OR FLUIDS TO START THE FIRE. DO NOT BURN Garbage OR FLAMMABLE FLUIDS.**
- **IF THIS ROOM HEATER IS NOT PROPERLY INSTALLED, A HOUSE FIRE MAY RESULT. TO REDUCE THE RISK OF FIRE, FOLLOW THE INSTALLATION INSTRUCTIONS. FAILURE TO FOLLOW THESE INSTRUCTIONS MAY RESULT IN PROPERTY DAMAGE, BODILY INJURY, OR LOSS OF LIFE.**
- **CONTACT THE LOCAL BUILDING OR FIRE OFFICIALS ABOUT RESTRICTIONS AND INSTALLATION INSPECTION REQUIREMENTS IN YOUR AREA. WHEN NOT ADDRESSED IN THIS MANUAL, OR BY LOCAL CODE AUTHORITIES, INSTALLATION SPECIFICATIONS AND REQUIREMENTS DEFER TO NFPA 211 OR CSA B 365**
- **DO NOT CONNECT THIS FIREPLACE TO ANY AIR DISTRIBUTION DUCT OR SYSTEM .**
- **EXTREMELY HOT WHILE IN OPERATION! KEEP CHILDREN, CLOTHING AND FURNITURE AWAY. CONTACT WILL CAUSE SKIN BURNS.**
- **NEVER OPERATE THE FIREPLACE WITH A CRACKED OR BROKEN GLASS PANEL.**
- **Install smoke detectors in the living areas and bedrooms of your home. Test them regularly and install new batteries twice annually. When installed in the same room as the stove, a smoke detector should be located as far from the stove as possible to prevent it from sounding when adding fuel to the fire.**
- **Avoid creating a low pressure condition in the room where the stove is operating. Be aware that operation of an exhaust fan or clothes dryer can create a low pressure area and consequently promote flow reversal through the stove and chimney system. The chimney and building, however, always work together as a system - provision of outside air, directly or indirectly to an atmospherically vented appliance will not guarantee proper chimney performance. Consult your local Jøtul authorized dealer regarding specific installation/ performance issues.**

Installation

Preparation

We strongly urge you to have your authorized Jøtul dealer install your new Jøtul C 550 Fireplace Insert.

- Check with local building officials to determine what permits may be required before installation.
- Notify your insurance company before installing this fireplace.

Unpacking the Fireplace

All firebox components of the Jøtul C 550 Fireplace Insert are contained within the carton on a single pallet. The Surround Kit is packaged separately. As you unpack the contents, inspect each item for damage. Notify your dealer of any damage such as dents, cracked glass, or broken bricks.

Contents:

- Firebox Assembly - including Firebricks
- Draw-Down Flue Collar Adaptor - including Pins
- Stove Hardware Bag
 - Fireplace Conversion Notice Plate
 - Blower Power Cord
 - AC Power Receptacle Lead
 - Blower Control Knob
 - Leg Levelers, (2) See Apendix, pg. 22.
 - Door Knob parts See Apendix, pg. 23.

Tools & Materials Required:

- work gloves
- safety glasses
- tape measure
- Phillips screwdriver
- power drill / 1/8" bit
- flashlight
- High-temperature sealant
- 1" (25 mm) masonry anchors or nails (two)
- 1/4" x 3/4" self-tapping screws (three)
- 10 mm (1/4") open end wrench or socket driver

Removing the Firebox from Pallet

1. Inspect the firebox assembly for damage and contact your dealer if any is found.
2. The firebox may be lightened by removing the door, firebricks and baffle plates. See page 12 for details on baffle plate removal.
3. The firebox is secured to the pallet by a steel bracket on each side and one screw in the bottom at the front. Use a 1/4 socket to remove these five screws and lift the firebox to disengage the brackets. Discard brackets.
4. Install the Door Knob parts in the order shown in fig. 21, page 22. Install the Blower Control Knob, found in the Miscellaneous Kit bag.

Jøtul C 550 Rockland Specifications

Performance

Fuel:	up to 24" Logs
Heat Output ¹ :	65,000 BTU/Hr.
Heating Capacity ² :	up to 2000 sq. ft.
Overall Efficiency ³ :	71%
Emissions:	7.1 g/hr.
Burn Time:	up to 10 hrs.
Dual Blowers:	90 cfm. each
Shipping Weight:	550 lbs. (250kg.)

The Jøtul C 550 Rockland Fireplace Insert meets U.S. EPA emission limits for wood heaters sold after July 1990, and is tested and listed to ANSI/UL 1482, and CAN/ULC S628.93. It is intended for installation in accordance with NFPA 211 or CAN/CSA B365.

¹ Maximum Heat Output based on total kilograms of dry wood burned in a one hour period. Under specific EPA test conditions, this heater has generated heat output rates ranging from 12,034 to 36,669 BTU's per hour. Heat output in residential installations may vary depending upon site-specific conditions.

² Heating Capacity and Maximum Burn Time will vary depending on design of home, climate, wood type and operation.

³ Overall Efficiency is based on a burn rate of .99 kg wood per hour.

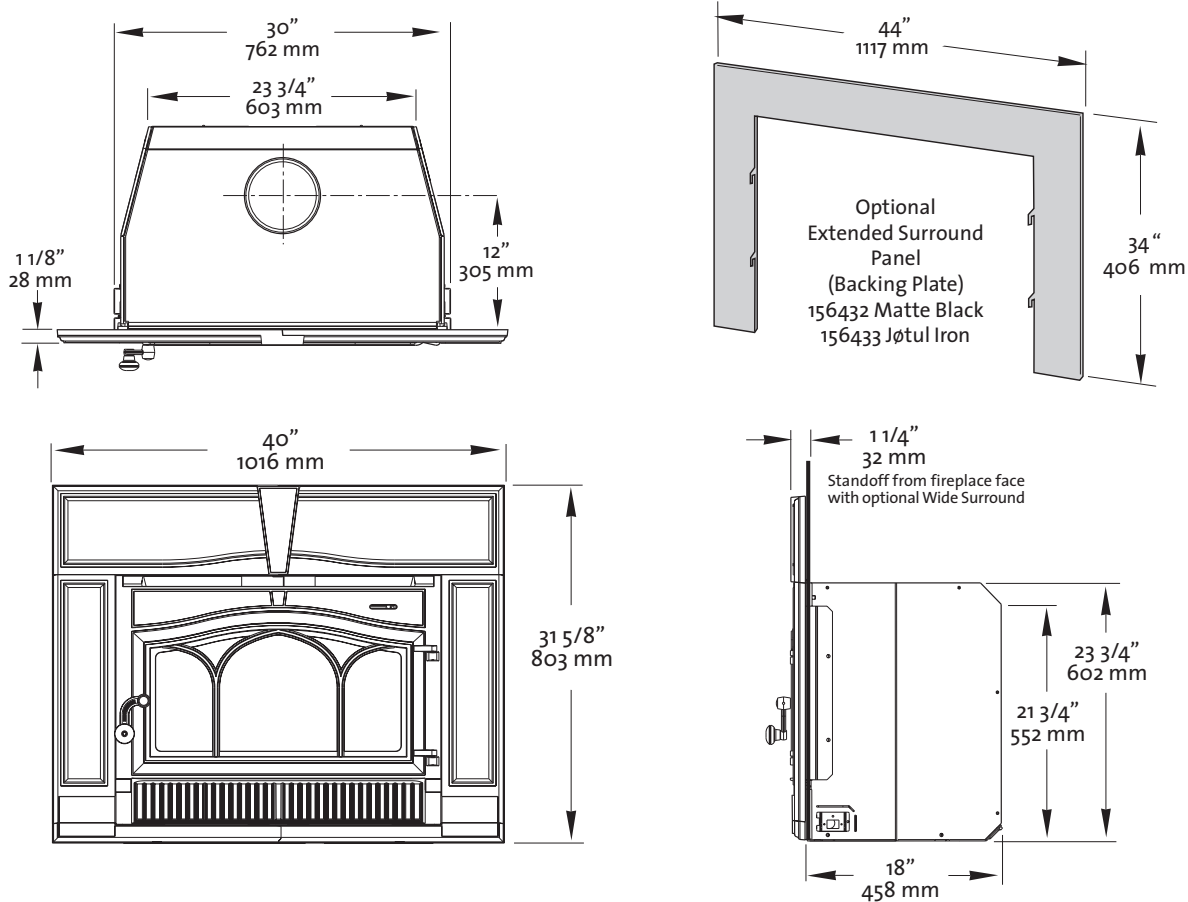

Figure 1. Jøtul C 550 Rockland Critical dimensions.

Installation

Masonry Fireplace Requirements

- The entire fireplace and chimney must be cleaned and inspected to NFPA 211 Level II standards before installation. The system must meet local building code requirements.
- The structure and components must be free of any defects such as cracks or broken bricks or flue tiles. Any damage must be repaired before installation of the fireplace insert.

Any opening that may exist between the masonry of the fireplace and the facing masonry must be permanently sealed.

- The chimney must have a clay tile liner or a stainless steel liner utilizing a positive connection.
- **Do not remove bricks or mortar from the fireplace or chimney.** However, masonry or steel may be removed from the smoke shelf and adjacent damper frame area to accommodate installation of a chimney liner, provided that their removal will not weaken the structure of the fireplace or chimney, and will not reduce protection for combustible materials.
- **Chimney Height:**
Minimum - 15 ft. (4.57 meters)
Maximum - 33 ft. (10.5 meters)

Minimum Fireplace Dimensions

- A:** Front Width* 33" (838 mm)
- B:** Height 23 3/4" (603 mm)
- C:** Rear Width 24" (610 mm)
- D:** Rear Height 22" (559 mm)
- E:** Depth 18" (457 mm)

*NOTE: Width dimension accommodates clearance for blower power cord routing.

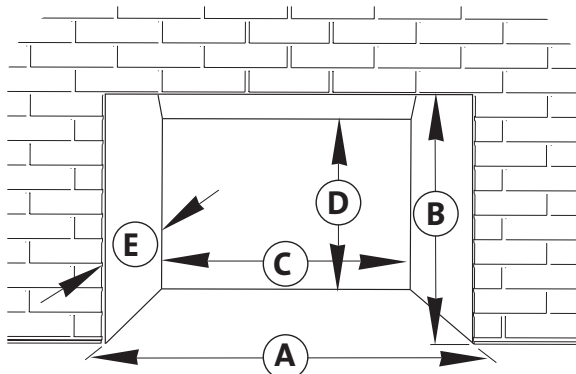

Figure 2. Minimum fireplace dimensions.

Factory-Built Fireplace Requirements

The Jøtul C 550 Rockland may be installed into a factory-built fireplace with the following conditions:

- The factory-built fireplace must be listed per UL 127 or ULC S610.
- The factory-built chimney system must be fully-lined with listed chimney liner meeting type HT requirements (2100°F) per UL 1777 (U.S.) or ULC S635 (CAN). Some liner manufacturers require insulation in order to achieve a UL 1777 or ULC-S635 listing. Check with the liner manufacturer to determine if insulation is required. Insulation is recommended, especially if the chimney is located in a chase outside of the building envelope. The liner must be securely attached to the insert flue collar and the chimney top.
- **THE TOP PLATE OF THE LINER SYSTEM MUST NOT BLOCK AIRFLOW BETWEEN THE COOLING WALLS OF THE FACTORY-BUILT AIR-COOLED CHIMNEY SYSTEM.** These airways **MUST** be left open under all conditions to maintain proper air-cooling of the chimney system. See fig. 3.
- The damper area or fireplace front must be sealed to prevent passage of room air into the chimney cavity.

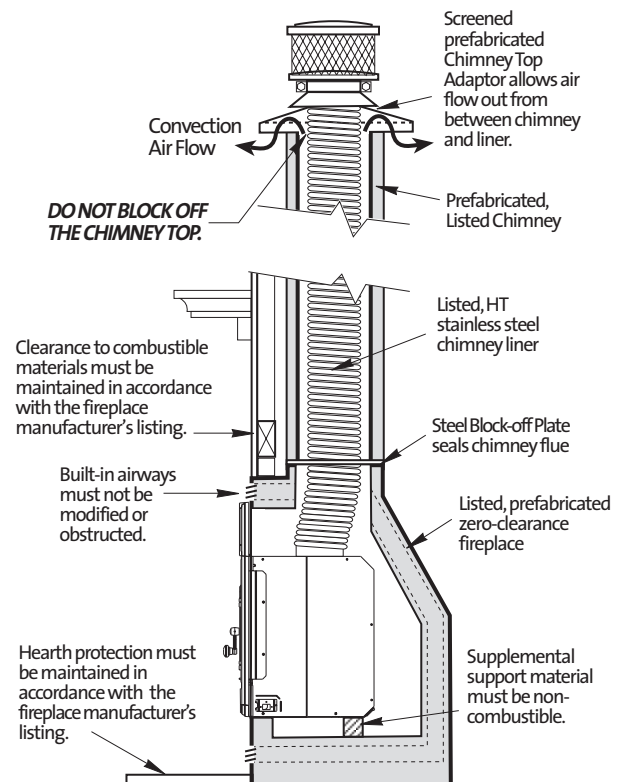

Figure 3. Prefabricated fireplace installation requirements.

Factory-Built Fireplace Requirements, cont'd.

- The convection chamber/louvers of the zero-clearance fireplace MUST NOT be blocked off. The use of the cast iron surround panels may not be possible in these instances. A custom-built surround panel system may be used provided it does not interfere with air circulation through the convection chamber/ louvers.
- Air flow within and around the factory-built fireplace shall not be altered by installation of the insert.
- Alteration of the fireplace in any manner is not permitted; i.e. firebrick or refractory panels MUST NOT be removed in order to accommodate the insert. Exceptions to this are:
 - a. External trim pieces, that do not affect the function of the fireplace, may be removed providing they can be stored on or within the fireplace for reassembly if the insert were to be removed.
 - b. The chimney damper may be removed to install the chimney liner.
- Inserts that project from the factory-built fireplace must be furnished with appropriate means of support. The weight of the insert must not compromise the means of support for the factory-built fireplace.
- Fireplace Conversion Notice 220508 must be permanently attached to the back of the fireplace. This metal label is included in the bag containing this manual.
- Final approval is contingent on the authority having local jurisdiction.

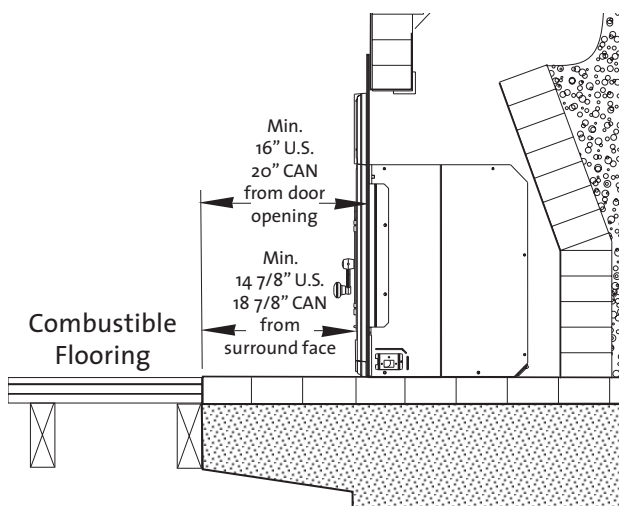

Figure 4. Required hearth protection if flush with combustible floor materials.

Hearth Protection Requirements

The floor area in front of fireplace insert must be protected from live sparks and radiant heat.

- **Materials:** Hearth protection must be non combustible insulating board such as 1/2" mill-board, or the equivalent mortared masonry material. Alternate protection must be composed of materials as specified by NFPA 211.

- **Protected Area:**
 U.S: 16" Deep x 37" Wide
 CAN: 20" Deep x 37" Wide
 See exception for 18" depth below.

U.S. : Front -
 The protection must extend at least 16 inches forward from the fireplace insert door opening as in fig. 4. (14 7/8" from Surround facing).

Canada: Front -
 The protection must extend at least 20 in. forward from the fireplace insert door opening, (18 7/8" from Surround facing).

Front protection may be reduced to 18" under the following conditions:

- a) it is composed of noncombustible material having an R value of .5 or higher such as 1/2" thick millboard. See Appendix A on page 23 for examples.
- b) it is raised a minimum of 2 1/2" and constructed on noncombustible materials in a code-approved masonry fireplace. See fig. 5.

U.S. & Canada: Sides - Protection must extend a minimum 18 1/2 in. to both sides of the centerline of the insert. See fig 6, A.

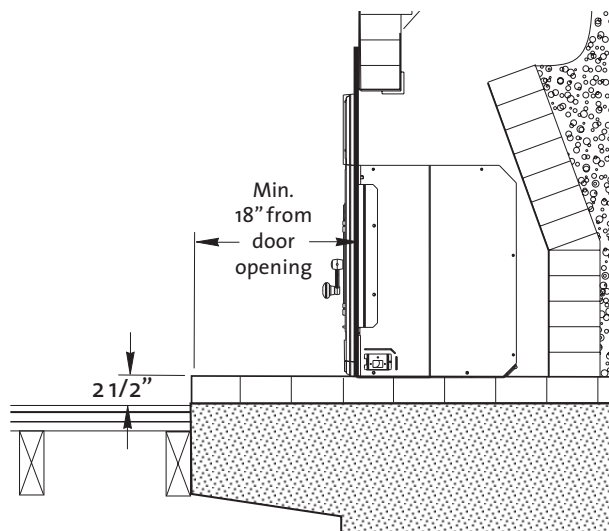

Figure 5. Canada only: Minimum depth with code-approved raised hearth.

Clearance to Combustible Materials

- There may be no combustible materials located anywhere within 36" (914 mm) of the front of the fireplace insert. This precaution includes items such as drapes or doors that could swing into the area within 36" of the insert.
 - Specific clearance (open space) must be maintained between the fireplace insert and combustible materials located above and to the side.
- See figures 5-6 for minimum dimensions.

Minimum Clearances

Clearances are measured from the hearth surface, door opening, or centerline as noted below.

- A:** Hearth Protection, *width from centerline:* 18 1/2" (470 mm)
- B:** Hearth Protection, *forward from door opening:* US: 16" / CAN: 20" (508 mm)
- C:** To Side Trim, *1" max. thickness, from centerline* 21 3/4" (552 mm)
- D:** To Side Room Wall, *from centerline:* 54" (1372 mm)
- E:** To Top Trim, *1" max. thickness, from hearth:* US: 51 3/4" / CAN: 57 1/2" (1460 mm)
- F:** To Mantel, *3 1/2" max. depth, from hearth:* US: 51 3/4" / CAN: 57 1/2" (1460 mm)
- To Mantel, *11 1/2" max. depth, from hearth* US: 57 3/4" / CAN: 63 1/2" (1613 mm)

See fig. 7 for clearances with Mantel Heat Shield.

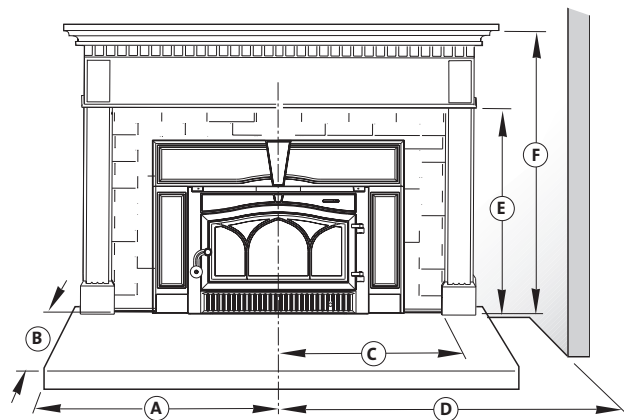

Figure 6. Minimum clearance to combustible materials.

Mantel Clearances

The installation must conform to the minimum mantel clearances specified in the chart below. These clearances may be reduced with installation of Jøtul Mantel Heat Shield 156448 as specified in the chart. Clearance reduction to mantel construction may also be made in conformance to NFPA 211 or CAN/CSA B365.

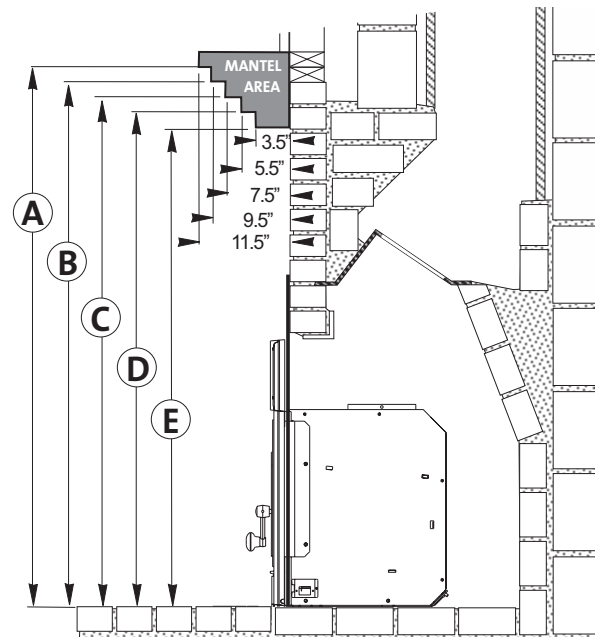

Figure 7. Mantel Clearance Detail - measured from the hearth surface to the lowest mantel surface.

	A	B	C	D	E
U.S.:	57 3/4"	56 1/4"	54 3/4"	53 1/4"	51 3/4"
CAN:	63 1/2"	62"	60 1/2"	59"	57 1/2"
	161.3 cm	157.4 cm	153.7 cm	150 cm	146 cm
U.S. & CAN: With Mantel Heat Shield 156448					
	48"	46 1/2"	45"	43 1/2"	42"
	127.9 cm	118.1 cm	114.3 cm	110.4 cm	106.6 cm

Chimney Connection Requirements

U.S. Only Requirements:

1. The insert must be connected to a code-approved masonry chimney with a direct (positive) flue connector into the first chimney liner section.
2. The cross-sectional area of the chimney flue may not be less than the cross-sectional area of the flue collar.
3. **A sealed block-off plate must be installed at the damper area of the existing fireplace**, unless the liner is connected to the top of the chimney. See fig. 8.
4. **For internal chimneys**, (no sides of the chimney exposed to the outside below the roofline,) a positive connection into the first flue tile is acceptable provided the tile is no larger than 8" x 12".
5. **For external chimneys**, (one or more sides are exposed to the outside below the roof line, including garages), a positive connection to the first flue tile is acceptable provided the tile is no larger than 8" x 8".
6. **A 6", 7", or 8" stainless steel liner, extending the full height of the chimney, is required** for those installations where the flue tile is greater than 8" x 12" for internal chimneys, or 8" x 8" for external chimneys.
In this case, a damper block-off plate is not required.

Canada Requirement:

The insert must be installed with a continuous chimney liner of 6" (152 mm) diameter extending from the fireplace insert to the top of the chimney. The chimney liner must conform to the Class 3 requirements of CAN/ULC-S635, Standard for Lining Systems for Existing Masonry or Factory-Built Chimneys and Vents, or CAN/ULC-S640, Standard for Lining Systems for New Masonry Chimneys. See fig. 9.

Do not use aluminum or galvanized steel pipe for chimney connection components - these materials are not suitable for use with solid fuel.

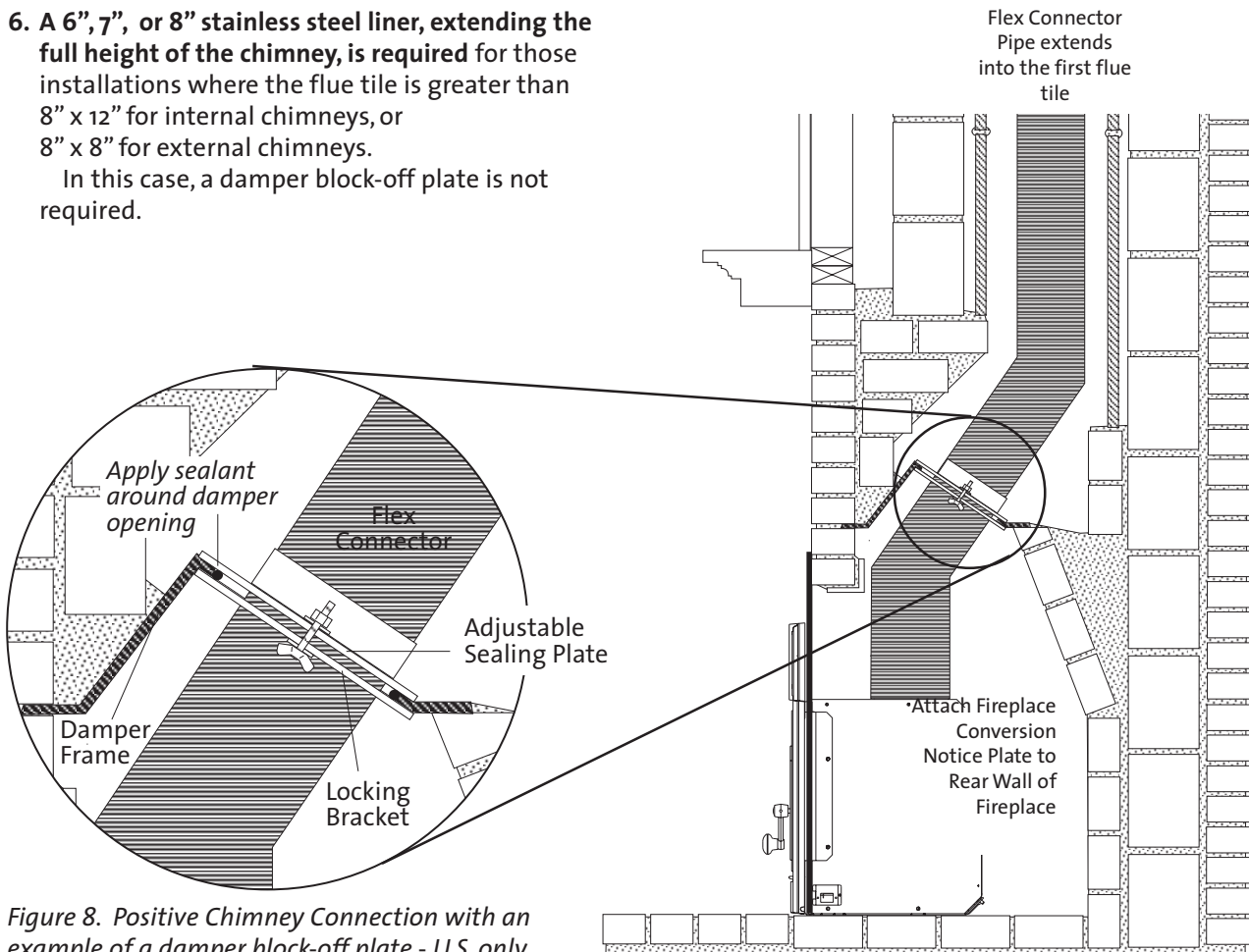

Figure 8. Positive Chimney Connection with an example of a damper block-off plate - U.S. only.

Fireplace Chimney Preparation

1. Remove the existing damper and linkage components from the fireplace. Alternatively, you can wire the damper plate to lock it in the open position. Thoroughly clean the firebox and smokesheaf area with a wire brush.
2. If the fireplace has been modified to accommodate installation, use anchors or masonry nails to attach the metal Fireplace Conversion Notice Plate (PN 220508) to the back wall of the masonry fireplace firebox where it will be readily seen should the insert be removed.
3. If appropriate, install the damper sealing plate according to the manufacturer's instructions. The sealing plate may require trimming to accommodate your specific fireplace damper frame.

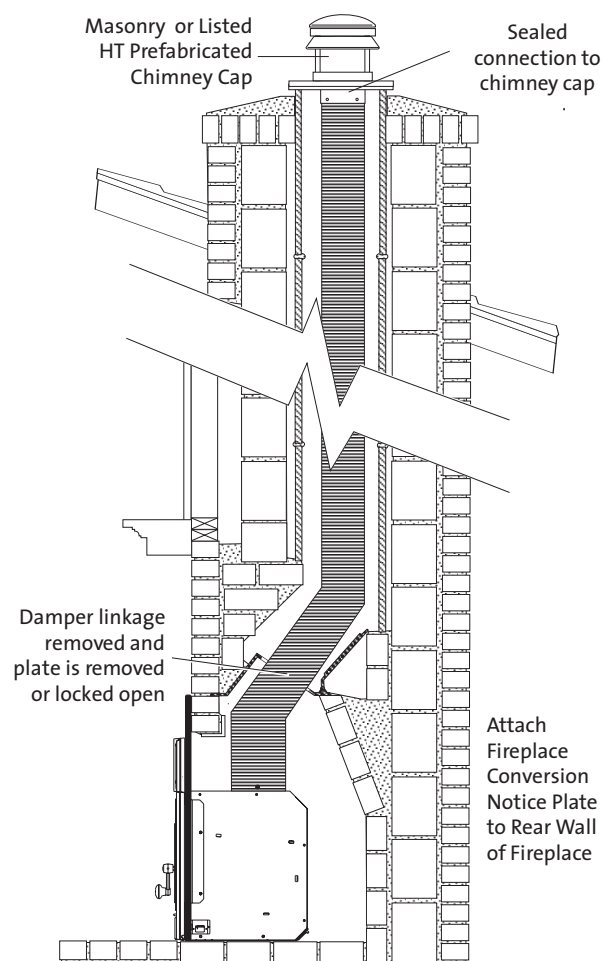

Figure 9. A fully-relined chimney is required in Canada and highly recommended in the U.S.

Installing the Fireplace Insert

Power Cord Orientation

1. Determine to which side the blower power cord will be routed. **DO NOT ROUTE THE POWER CORD ACROSS THE FRONT OF THE FIREPLACE.**
2. Insert the AC power receptacle lead through the appropriate inlet in the side of the firebox. See fig. 10. Remove the #8 x 5/8" phillips screw already in place and engage the receptacle bracket with the tab in the inlet opening. Reinstall the screw.
3. Route the AC power wire harness through the hole in the Inner Shroud and around the front of the blower. Plug the male quick-connector into the corresponding female connector on the blower wire harness, located between the two blowers. Loosen the Control Switchplate wingnut to swing the switch assembly out for better access to the female connector.

After connection, relocate the whole wire harness behind the blower and resecure the switchplate.

4. Plug the power cord into the receptacle, but do not plug it into the wall outlet until the installation is complete.

Install the Draw-Down Adaptor

1. Insert the end of the chimney flue flex pipe as far as it will go into the non-crimped end of the adaptor or, if appropriate, the adaptor that may be supplied by the flex liner manufacturer. Orient the draw-down adaptor so that the retainer pin will be parallel with the front of the fireplace. This will ease locating the cotter pin hole. Fig. 11.
2. Drill holes through the flex pipe at the three pilot hole locations in the adaptor and secure with sheet metal screws.

Install the Firebox

The cast iron baffles must be removed to secure the draw-down adaptor to the firebox. The Left Baffle has two bosses cast into it that engage with corresponding holes in the air tubes to lock each tube in correct position. Use a flashlight to locate the bosses by lifting up on the Left Baffle. See fig. 12.

1. Lift up the Left Cast Iron Baffle to disengage the locator boss from the Front Air Tube, and pull the air tube forward and out of the side manifolds.
2. Keeping the Rear Air Tube in place, push up on the Right Baffle and remove the Left Baffle, dropping it down and out.
3. Lift and remove the Right Baffle.
4. Locate the fireplace insert in its final position. From within the firebox, reach up and pull the Draw-down Adaptor into the insert flue collar.

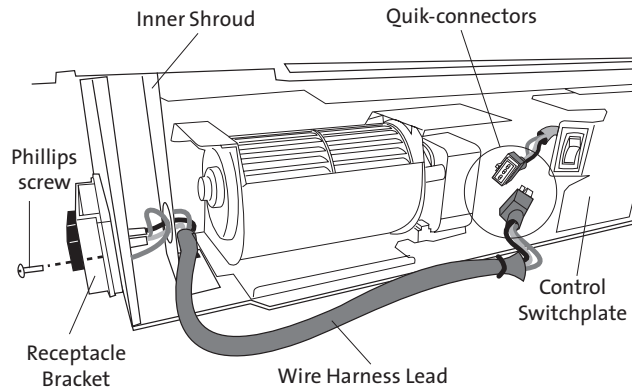

Figure 10.
Routing the AC wire harness leads.

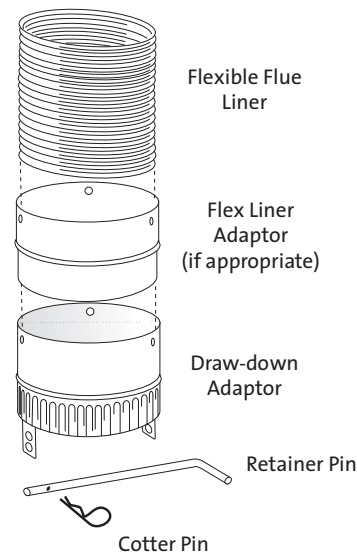

Figure 11.
Install
Draw-Down
Adaptor

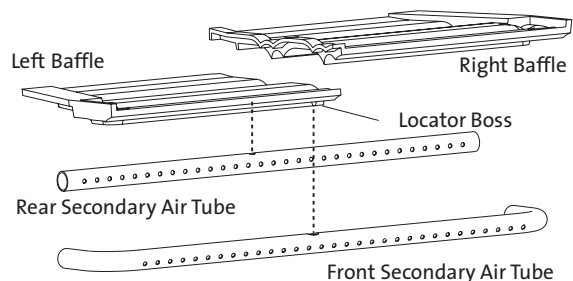

Figure 12.
Remove baffles and Front Secondary Air Tube..

5. Insert the retainer pin through the appropriate holes in the adaptor ears, and lock the retainer pin in place using the cotter pin.
6. Replace first the right baffle, then the left baffle, followed by the air tubes. **ADJUST THE AIR TUBES AS NECESSARY TO BE SURE EACH IS PROPERLY ENGAGED WITH THE ADJACENT LOCATOR BOSSES ON THE LEFT BAFFLE.**

Figure 13.
Surround Panel assembly
viewed from backside.

Tools Required:

- 10 mm socket or wrench

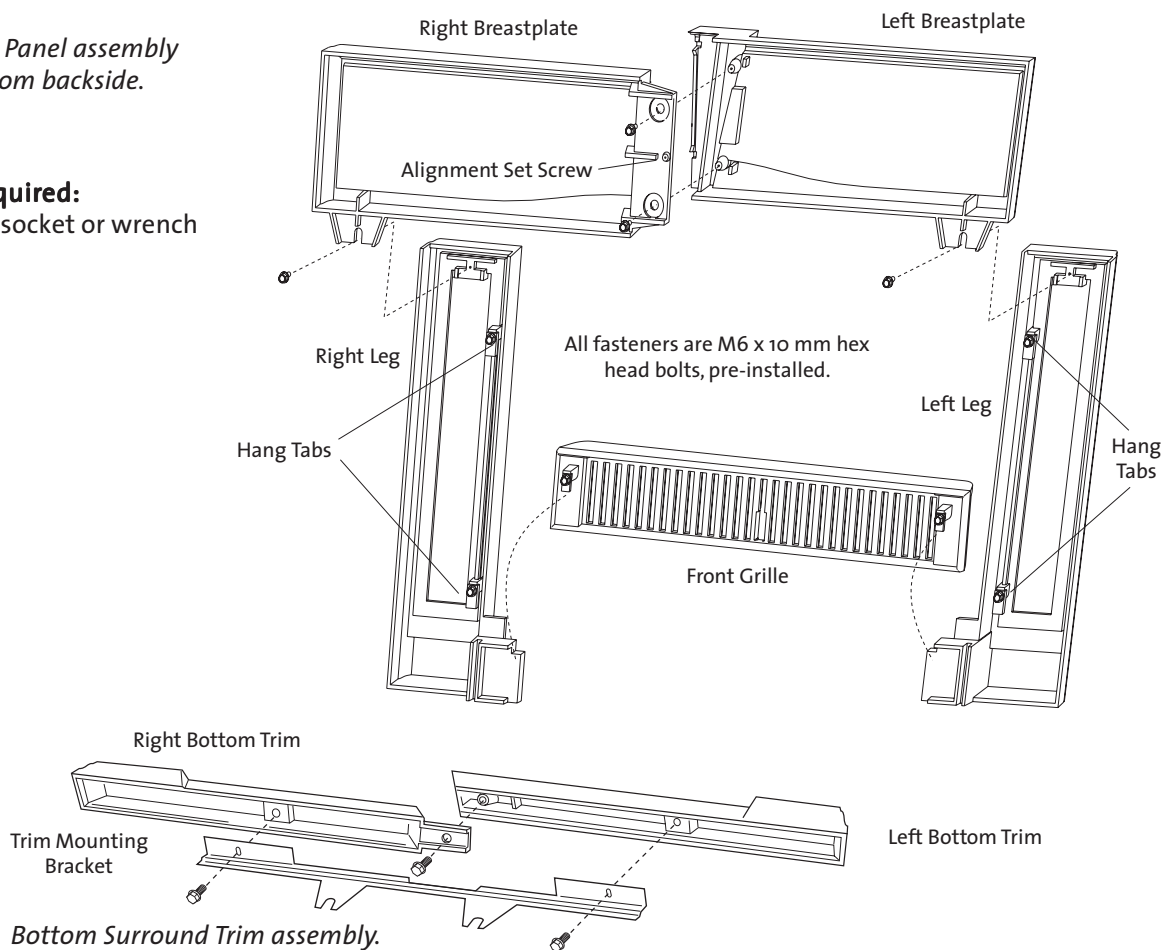

Figure 14. Bottom Surround Trim assembly.

Surround Assembly

All fasteners have already been installed in the appropriate locations at the factory. You will need to remove them, attach the parts together as described below and reinstall the fasteners at those locations.

1. Layout the parts. Place the castings face down on a protective surface such as carpeting, blankets or a sheet of cardboard. See fig. 13.
2. Attach the Breastplates to each other. Use a 10 mm socket or wrench with two M6 x 10 hex head flange bolts. Adjust the set screw to obtain parallel alignment of the two plates.
3. Attach the Leg plates. *The Legs must be oriented with the Hang Tabs on the inside edges as shown in fig. 12.* Use the two remaining M6 x 12 hex head flange bolts to attach the Legs to the Breastplate assembly.
4. Attach the two Bottom Surround Trim panels together with the single M6 x 10 hex bolt. Attach the Trim Mounting Bracket to the back of the Bottom Trim assembly using the other two M6 x 10 bolts and washers. Orient the bracket as shown in fig. 14.
5. If appropriate, attach the Extended Surround Panel to the firebox. See illustration on page 6. With the painted side facing out, engage the hooked tabs on panel with the slots in the backside of the Surround Brackets on the firebox. Extend the blower power cord out beyond the front of surround panel.
6. Attach the Bottom Trim assembly to the two studs located in the firebox floor between the blowers using the M6 nuts already in place.
7. Attach the Surround assembly to the Firebox. Lift the entire assembly upright and position it in front of the insert firebox. The four Hang Tabs on the surround legs must engage with the adjacent cutouts in the two brackets on the sides of the firebox opening. The surround will easily engage with these brackets if the firebox is slightly proud of the fireplace opening.
8. Check the alignment of the breastplates for “bowing” and adjust the set screw as necessary.
9. Push the entire unit into position so that the surround is flush against the fireplace face.

Operation

Read the following section carefully before building a fire in your fireplace insert..

Fuel

This stove is designed to burn natural wood ONLY. Wood that has been air-dried for a period of 6 to 14 months will provide the cleanest, most efficient heat. **Frequent use of green or inadequately seasoned wood is conducive to creosote accumulation and generally poor performance.**

DO NOT BURN...

- Coal
- Treated or painted wood
- Garbage
- Chemical Chimney cleaners
- Cardboard
- Colored paper
- Solvents
- Any synthetic fuel or logs

The burning of any of these materials can result in the release of toxic fumes. **NEVER USE GASOLINE, GASOLINE-TYPE LANTERN FUEL, KEROSENE, CHARCOAL LIGHTER FLUID, OR SIMILAR LIQUIDS TO START OR "FRESHEN-UP" THE FIRE.** Always keep such liquids away from the heater at all times.

WARNING

NEVER ALLOW THE FIRE TO REST DIRECTLY ON THE GLASS. THE LOGS SHOULD ALWAYS BE SPACED AT LEAST ONE INCH FROM THE GLASS TO ALLOW FOR PROPER AIR FLOW WITHIN THE STOVE.

OPERATE THIS FIREPLACE INSERT ONLY WITH THE FRONT DOOR FULLY CLOSED. OPERATION WITH A PARTIALLY OPENED DOOR MAY RESULT IN OVER-FIRING. ALSO, IF THE DOOR IS LEFT PARTLY OPEN, GAS AND FLAME MAY BE DRAWN OUT OF THE STOVE OPENING, CREATING RISKS FROM BOTH FIRE AND SMOKE.

Air Control Settings

A single lever regulates the Primary Air flow that controls the intensity of the fire and consequent heat output and burn time. This lever is located within the slot on the upper right front of the fireplace insert.

When first starting or reviving the fire, the control lever should be set at the far right position to allow the maximum amount of air into the stove. See fig.15. After the fire is well-established, the lever should be set at position to moderate incoming air to maintain the desired long term heat output and/or burn time.

In general, the more air made available to the fuel will result in the hottest fire intensity and the fastest fuel consumption. Alternatively, the less air made available to the firebox will result in low heat output and slow fuel consumption.

Blower Settings / Air Control

Use the following guide for best performance.

Burn Rate	Air Control Setting	Blower Speed
Low	Fully Closed	Low / On at 30 min.
Med. Low	1/16"-1/8" Open	Low / On at 30 min.
Med. High	3/16"-1/4" Open	Low / On at 30 min.
High	Max. Open	High / On

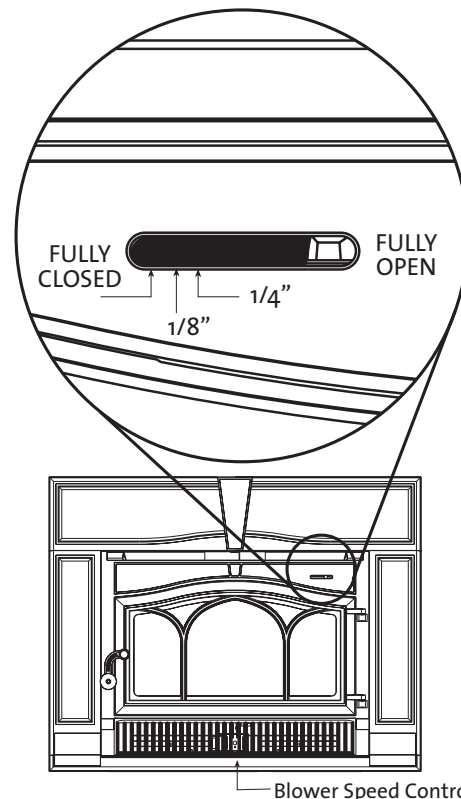

Figure 15. Air Control Setting

Starting and Maintaining a Fire

Burn only solid wood directly on the bottom plate of the stove. Do not elevate the fire in any way.

1. Set the Air Control Lever in the full open position.
 2. Crumple several sheets of newspaper directly on the bottom plate..
2. Place several pieces of small dry kindling (approx. 1" in diameter) on top of the newspaper, with two to three small logs (approx. 2" to 3" in diameter) on top.
3. Light the fire and close the door. Gradually build the fire by adding larger and larger logs as the fire develops a bed of coals.
4. When you have added the final logs, adjust the Air Control Lever to provide the desired fire intensity.

Experiment with a variety of air control settings to determine the best one for your individual circumstances. Remember that fuel characteristics, chimney system condition, building design, and weather conditions all affect the performance of your fireplace insert. In time, you will discover how these elements combine and how you can work with them to achieve satisfactory performance.

Break-in Period

The cast iron parts of your fireplace insert require a break-in process to allow them to gradually adjust to thermal expansion and contraction. This is accomplished by building a series of three or four fires, each somewhat hotter than the last. Allow the fireplace insert to cool completely before building the next fire.

Limit the first fire to just kindling and a couple of 1 -2 inch logs and add progressively more and larger logs to subsequent fires, keeping the Air Control set to the fully open position.

It is normal for a new fireplace insert to emit odor and possibly smoke during the first few fires. This is characteristic of the burn-off of residues from the manufacturing process and the curing of painted surfaces. Open a window near the fireplace insert to provide plenty of fresh air to the room during this "seasoning" period.

WARNING!
NEVER OVER-FIRE THE STOVE. IF ANY PART OF THE STOVE OR CHIMNEY GLOWS, YOU ARE OVER-FIRING. A HOUSE FIRE OR SERIOUS DAMAGE TO THE STOVE OR CHIMNEY COULD RESULT. IF THIS CONDITION OCCURS, IMMEDIATELY CLOSE THE AIR CONTROL.

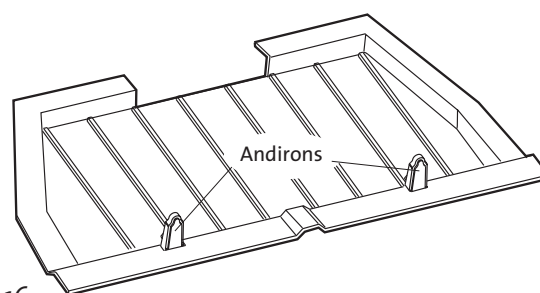

Figure 16.
 Fuel load area - keep logs behind the andirons.

Adding Fuel to the Fire

When reloading the stove while a bed of hot embers still exists, follow this reloading procedure:

- Always wear stove gloves when tending to the fire.
- Push the Air Control Lever to the full open position (far right).
- **Always wait a few seconds before opening the door.** This allows the renewed air circulation to clear unburned gases from the firebox.
- Use a stove tool or poker to distribute the hot embers equally around the firebox.
- Load the fuel, usually with smaller logs first. **Keep logs behind the andirons.** See fig.16.
- Close the doors and secure the latch.
- Wait 5 – 10 minutes for the fire to reestablish before adjusting the Air Control Lever for the desired heat output. If a thick bed of live coals is present, you may be able to add fuel and immediately set the air control without waiting for the fire to be reestablished.

Creosote Formation

This appliance is designed to burn wood cleanly and efficiently when operated as described in this manual. However, when wood is burned slowly and at low temperatures, tar and other organic vapors are produced which condense on the relatively cooler chimney flue surfaces to form creosote. Failure to keep the chimney system free of creosote build up could result in a chimney fire.

The creosote that accumulates in the chimney is highly flammable and is the fuel of chimney fires. To prevent chimney fires, it is important to have the chimney flue and connector pipe cleaned and inspected at the beginning of the heating season and then inspected twice per month during frequent use. Clean the chimney whenever creosote accumulation of 1/4" or more is evident. A qualified chimney sweep or other authorized service person can provide this service.

It is also important to remember that chimney size, temperature and height all affect draft which in turn affects the formation of creosote. An exterior chimney, whether masonry or prefabricated steel, will be exposed to cold outside temperatures, and consequently, will be more prone to creosote accumulation than an interior flue.

A chimney flue located within the home interior will benefit from the insulating characteristics of the building itself. Consequently, the flue system will be less conducive to condensation of unburned gases and minimal creosote accumulation will result.

As a general rule, try to avoid burning the insert at the lowest air control settings. Although a low setting will prolong burn time, it may also result in incomplete combustion. In reducing the fire intensity, draft is weakened and the chimney flue cools. This, together with the increase in unburned gases, leads to rapid creosote accumulation.

Blower Operation

Access the blower control panel by lifting the cast iron lower grille up off the insert.

The dual blowers will enhance heat circulation around the firebox and out into the room. In the **Automatic** setting, the blowers are controlled by a heat activated switch (snapstat) that will only function when the speed control is ON. After the fire has been burning for a time, the snapstat will react to the heat and activate the blowers. Conversely, the blower will continue to operate until the snapstat cools as the fire wanes. The blowers will then shut off automatically.

The **Manual** setting overrides the snapstat functionality allowing blower operation regardless of temperatures.

For best performance, do not turn the switch on until after the fire is well-established.

If the blower is not needed, place the blower control switch in the OFF position.

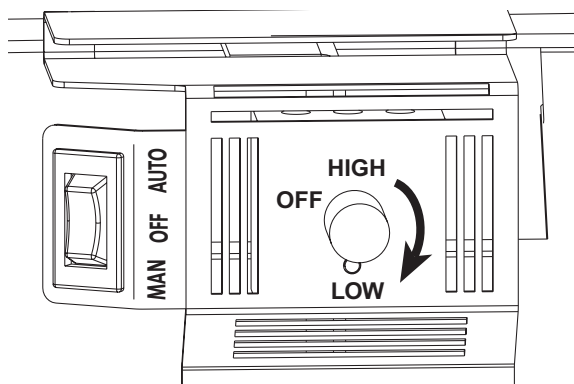
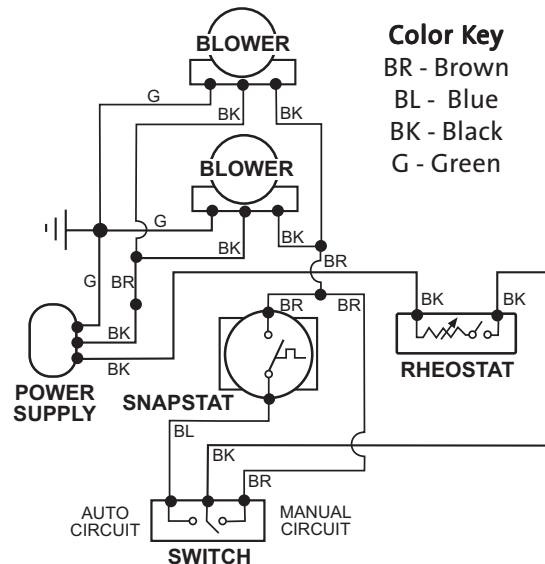

Figure 17. Blower and speed controls.

WARNING !

- **THIS BLOWER MUST BE ELECTRICALLY GROUNDED IN ACCORDANCE WITH LOCAL CODES OR, IN THE ABSENCE OF LOCAL CODES, WITH THE CURRENT ANSI/NFPA 70, NATIONAL ELECTRICAL CODE OR CSA C22.1-CANADIAN ELECTRICAL CODE.**
- **THIS UNIT IS SUPPLIED WITH A THREE-PRONG (GROUNDING) PLUG FOR PROTECTION AGAINST SHOCK HAZARD AND SHOULD BE PLUGGED DIRECTLY INTO A PROPERLY GROUNDED THREE-PRONG RECEPTACLE. DO NOT CUT OR REMOVE THE GROUNDING PRONG FROM THE PLUG.**
- DO NOT USE ANY POWER SUPPLY CORD OTHER THAN THAT SUPPLIED WITH THIS UNIT.**
- **ALWAYS DISCONNECT THE POWER SUPPLY WHEN PERFORMING ANY SERVICE ON THE FIREPLACE INSERT.**



NOTE: Terminals and switch markings are on opposite ends of the switch. See below.

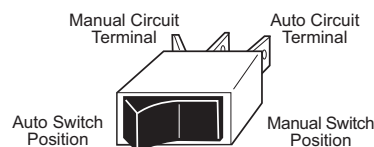

Figure 18. C 550 Wiring diagram.

Maintenance

Ash Removal

Always wear stove gloves when handling ashes.

Ash removal will be required periodically depending on how frequently the stove is used. Use a steel ash shovel and metal container with a tight-fitting lid.

NEVER USE A PAPER OR PLASTIC BAG AS AN ASH RECEPTACLE.

The container of ashes should be placed on a noncombustible floor or on the ground, well away from all combustible materials, pending final disposal. If the ashes are disposed of by burial in soil or otherwise dispersed, **they should be kept in the closed container until all coals and cinders have thoroughly cooled.**

Glass Care

Cleaning

Occasionally it will be necessary to clean the carbon deposits and fly ash off of the glass. If deposits are allowed to remain on the glass for an extended period of time, the glass may become etched and cloudy.

Creosote deposits should burn off during the next hot fire.

1. The glass must be COMPLETELY COOL.
2. Only use a cleaner that is specifically designed for this purpose. **DO NOT USE ABRASIVE CLEANING AGENTS.** The use of abrasives will damage the glass, leaving a frosted surface. Crumpled newspaper is an especially good cleaning material.
3. Rinse and dry glass completely before lighting a fire.

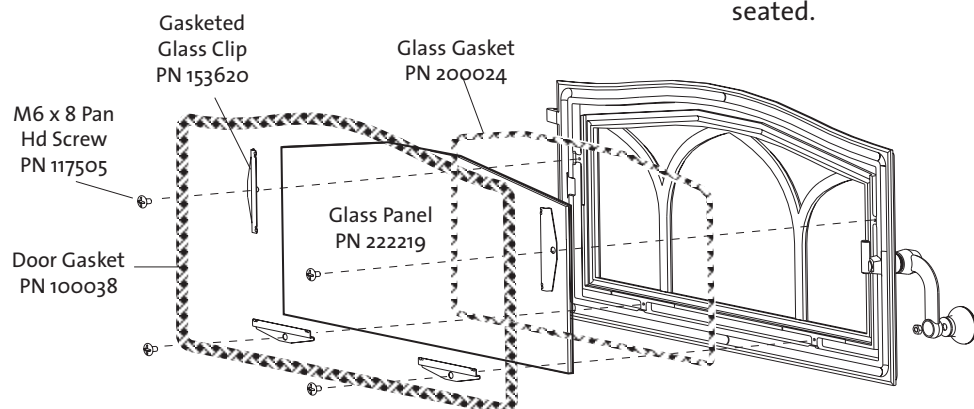

Figure 19.
Replacing the
door glass and
gaskets.

Glass Replacement

Always operate the doors slowly and cautiously to avoid cracking or breaking the glass. Never use the door to push wood into the firebox. If the glass becomes cracked or broken follow the replacement procedure below.

IMPORTANT:

NEVER OPERATE THE STOVE WITH A CRACKED OR BROKEN GLASS PANEL. Replace glass only with part # 156467 specifically designed for the Jøtul C 550 Rockland Fireplace insert. Do not use substitutes. Replacement glass can be ordered from your Jøtul dealer.

1. Remove the door from the stove and place on a flat surface.
2. First loosen and then carefully remove all of the glass clips from the inside of the door. See fig. 19.
3. Remove all pieces of the glass panel and gasketing.
4. Remove all remaining debris from the glass area using a wire brush.
5. Apply a small bead of gasket/stove cement and the new gasket. Do not overlap the ends of the gasket rope.
6. **Orient the glass with the IR Coating label facing out.** Hold the glass at an angle to see the word "COATED" located at the lower edge. This side should face out when placed in the door. Center the new glass panel over the gasket and loosely reinstall the glass clips. Tighten the clips, alternating at opposite corners. Avoid applying uneven pressure on the glass..
7. It may be necessary to retighten the glass clips after the stove has burned and the gasketing has seated.

General Maintenance

Regular maintenance will assure proper performance and prolong the life of your fireplace insert.. The following procedures do not take long and are generally inexpensive. When done consistently, they will help increase the life of your fireplace insert and assure satisfactory performance.

- Thoroughly clean the insert. Enamel surfaces should be cleaned with a moist cloth and polished dry.
- Empty firebox of all soot and ashes. Never use a household vacuum cleaner to remove ashes. Only a shop vacuum with a metal container is acceptable and only when you are certain the ashes are cold.
- Inspect the firebox using a utility light inside and out for cracks or leaks. Replace all cracked bricks and repair leaks with furnace cement.

Removing the Insert for Cleaning

U.S. Direct-connection Only:

1. Disconnect the blower power cord from its outlet.
2. Open the firebox door and pull the insert out enough to disengage the surround panel assemblies by lifting up off of the brackets.
3. Lift up the Left Cast Iron Baffle to disengage the locator boss from the Front Air Tube, and pull the air tube forward and out of the side manifolds.
4. Keeping the Rear Air Tube in place, push up on the Right Baffle and remove the Left Baffle.
5. Lift and remove the Right Baffle.
6. Slide the Rear Air Tube to one side to disengage it from the Side Manifolds.
7. Remove the retainer pin from the Draw-down Adaptor. Push up on the draw-down bar to disengage the adaptor from the insert
8. Pull the firebox and cabinet forward as a unit. The flue connector, liner, and chimney can now be inspected and cleaned.
9. See page 12 for reassembly procedures.

Canada Installations (Full Reline):

The chimney liner can be swept directly into a bucket placed under the flue outlet, with removal of the two cast iron baffle plates.

1. Lift up the Left Cast Iron Baffle to disengage the locator boss from the Front Air Tube, and pull the air tube forward and out of the side manifolds.
2. Keeping the Rear Air Tube in place, push up on the Right Baffle and remove the Left Baffle.
3. Lift and remove the Right Baffle.
4. Slide the Rear Air Tube to one side to disengage it from the Side Manifolds.
5. Reassemble in the reverse order, being sure to engage the locator bosses on the Left Baffle with the corresponding holes in the Secondary Air Tubes.

Gaskets

Check door and glass gaskets for seal integrity. The gaskets should be soft enough to be somewhat resilient to the touch. Over time, gaskets will compress and harden. Replace worn-out or hardened gaskets with the appropriate size material available from your local Authorized Jøtul Dealer.

To check the seal of the front doors, close and latch the doors on a dollar bill and slowly try to pull the dollar bill free. The seal is too loose if the bill can be easily removed. Adjust the door latch and test again.

Replacement Gaskets

Glass

LD .250 Fiberglass Rope 66" 200024

Door

LD2 .350 Fiberglass Rope 70" 100038

Front

LD2 .360 Fiberglass Rope 90.5" 117587

Air Manifold, Outer

LD2 .250 SA Fiberglass Rope 30" 129644

Air Manifold, Inner

.125 x 8 mm Flat SA 24" 127215

Gasket Replacement

See the chart below for replacement gasket specifications. See also figs. 19-20 for locations.

1. Remove the old gasket material with a pliers and thoroughly clean the channel with a wire brush.
2. Lay out the new gasket around the channel to determine length. Trim the gasket to leave 1" excess.
3. Apply a small bead of gasket or furnace cement in the channel.
4. Lightly press the new gasket into the channel, being careful to avoid compressing or stretching it. Trim the gasket further as necessary to allow the tail end to slightly overlap the other end.
5. Wait ten minutes to allow the cement to set and then close and latch the doors. Reopen the doors and use a damp cloth to wipe away any excess cement that may be squeezed out from under the gasket.

Jøtul C 550 Rockland Illustrated Parts Diagram

Use only genuine Jøtul replacement parts.
Do not substitute parts from any other manufacturer. See your local Authorized Jøtul Dealer or contact us directly:

Jøtul North America
55 Hutcherson Dr.
Gorham, Maine 04038

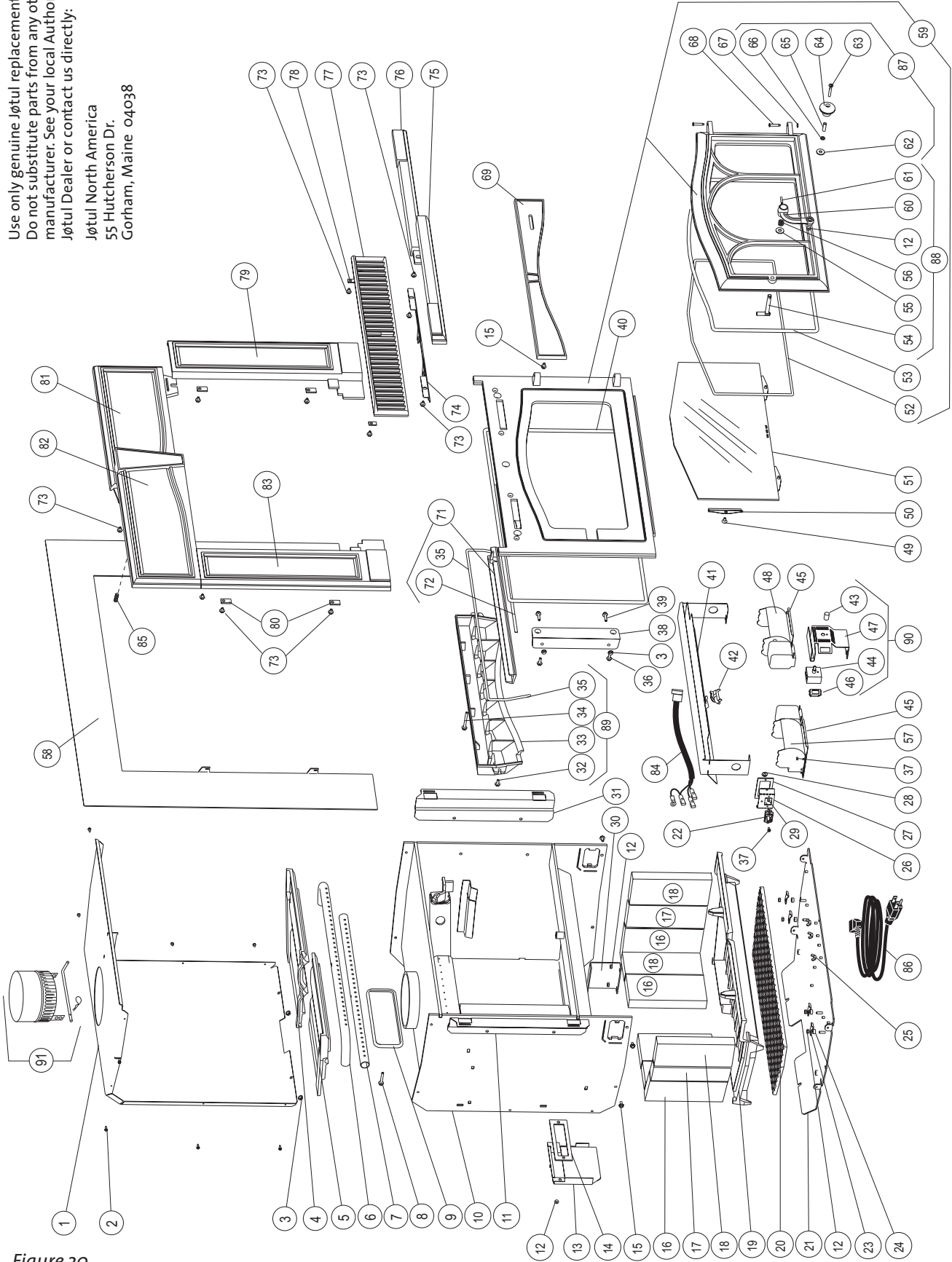

Figure 20.

Jøtul C 550 Rockland Parts List

No.	Description	Part Number
1.	Rear Shroud	222027
2.	Screw, #8 x 1/2" Hex Slit	117917
3.	Nut, M6 Flange	117968
4.	Right Baffle Plate	104314
5.	Left Baffle Plate	104313
6.	Secondary Air Tube, Front	222096
7.	Secondary Air Tube, Rear	222296
8.	Bolt, M6 x 40 SS Hex Hd	117997
9.	Brick Retainer, Cast Iron	104300
10.	Firebox Cavity	222026
11.	Surround Support, Left	222201
12.	Nut, M6 Hex	9930
13.	Secondary Air Channel	222271
14.	Blower Shield Assembly	221750
15.	Bolt, M6 x 12 Hex Hd Flange	117130
16.	Brick, 4.5 x 9.0 Refractory	129082
17.	Brick, 3.0 x 9.0 Refractory	220518
18.	Brick, 3.5 x 9.0 Refractory	222226
19.	Firebox Grate Plate	104312
20.	Insulating Panel, Grate	222433
21.	Shroud Assembly, Base	222028
22.	AC Power Receptacle	221790
23.	Clip, Attachment	222096
24.	Spacer, .250 x .500	117994
25.	Nut, M6 Wing	117975
26.	Receptacle Mounting Plate	222442
27.	Gasket, Receptacle Mounting Plate	129670
28.	Weld nut, M4	118067
29.	Screw, M4 x 8 PH PH ZINC	117920
30.	Firebox Support	222223
31.	Surround Support, Right	222200
32.	Bolt, M6 x 16 Flange Head	99625
33.	Air Wash Manifold	104310
34.	Bolt, M6 x 60 Hex Head Serr. Flange	99101
35.	Gasket, LD .250 SA Fiberglass Rope- Outer, Air Manifold	129644
36.	Bolt, M6 x 20 Hex Head	117117
37.	Screw, #8 x .50 Hex Slot	117917
38.	Cast Attachment Plate	156792
39.	Bolt, M6 x 25 Flange Hex	118019
40.	Rope Gasket, Fiberglass - LD .360 x 6.5 ft. - Front Plate	100038
41.	Shroud, Blower	222221
42.	Snapstat, 110°F - 20°F	220755
43.	Knob, Rheostat	221788
44.	Rheostat, Solid State Variable Speed	221787
45.	Blower Base	222220
46.	Rocker Switch	220703
47.	Controls Bracket	222222
48.	Blower, 60 cfm Crossflow, RT DR.	156477
49.	Screw, M6 x 12 Pan Head	117505
50.	Glass Clip w/ gasket	153620
51.	Ceramic Glass panel	222219
52.	Rope Gasket, Fiberglass LD .250 x 5.5' - Glass Panel	200024
53.	Rope Gasket, Fiberglass LD .360 x 70" - Door	100038
54.	Door Latch Bolt	221720
55.	Washer, Door Handle	117587
56.	Compression Spring, Door Handle	126164
57.	Blower, 60 cfm Crossflow, LFT DR	156476
58.	Extended Surround (optional) / Matte Black Paint	156432

*Does not include #87 Door Knob Kit

No.	Description	Part Number
58.	Extended Surround (optional) / Jøtul Iron Paint	156433
59.*	Front & Door Asy, Complete / Matte Black Paint	156482
	Front & Door Asy, Complete / Blue Black Enamel	156483
	Front & Door Asy, Complete / Jøtul Iron Paint	156484
60.	Cast Iron Door Handle	103712
61.	Roll Pin, 5 mm x 24 mm	117733
62.	Washer, Insulating	124385
63.	Bolt, M6 x 40 PHP	117796
64.	Door Knob, Wooden	126244
65.	Sleeve, Door Handle	126229
66.	Washer	110904
67.	Washer, M6, 12 x .05	117588
68.	Hinge Pin	127075
69.	Air Cover Plate, Matte Black Paint	156496
	Air Cover Plate, Blue Black Enamel	156486
	Air Cover Plate, Jøtul Iron Paint	156497
71.	Air Slider, Matte Black Paint	156712
	Air Slider, Jøtul Iron Paint	156713
	Air Slider, Nickel Plated	156714
72.	Gasket, .125 x 8 mm Flat SA - Inner, Air Manifold	127215
73.	Bolt, M6 x 10 Hex Hd Flange	9962
74.	Bracket, Bottom Trim	222427
75.	Trim, Bottom Left - Matte Black Paint	156706
	Trim, Bottom Left - Blue Black Enamel	156491
	Trim, Bottom Left - Jøtul Iron Paint	156707
76.	Trim, Bottom Right - Matte Black Paint	156708
	Trim, Bottom Right - Blue Black Enamel	156492
	Trim, Bottom Right - Jøtul Iron Paint	156709
77.	Control Door, Matte Black Paint, inc. hardware	156479
	Control Door, Blue Black Enamel	156480
	Control Door, Jøtul Iron Paint	156481
78.	Hang Tab	129680
79.	Surround Leg, Right - Matte Black Paint	156704
	Surround Leg, Right - Blue Black Enamel	156490
	Surround leg, Right - Jøtul Iron Paint	156705
80.	Hang Tab	128401
81.	Surround Panel, Breastplate, Right - Matte Black	156700
	Surround Panel, Breastplate, Right - Blue Black	156488
	Surround Panel, Breastplate, Right - Jøtul Iron	156701
82.	Surround Panel, Breastplate, Left - Matte Black	156498
	Surround Panel, Breastplate, Left - Blue Black	156487
	Surround Panel, Breastplate, Left - Jøtul Iron	156499
83.	Surround Leg, Left - Matte Black Paint	156702
	Surround Leg, Left - Blue Black Enamel	156489
	Surround Leg, Left - Jøtul Iron Paint	156703
84.	AC Harness w/ Receptacle, Replacement	156485
85.	Set Screw, M6 x 10 mm - Surround adjustment	04-117720
86.	Blower Power Cord, HT - Offset Angle	222093
87.	Wooden Knob Replacement Kit	151991
88.	Handle Asy, Complete / Matte Black Paint	156320
	Handle Asy, Complete / Nickel Plated	156021
89.	Airwash Manifold, inc. gasket / Matte Black Paint	156710
	Airwash Manifold, inc. gasket / Jøtul Iron Paint	156711
90.	Blower Control Module, inc. #43, 44, 46, 47	156715
91.	Draw-down Adaptor	156073

Jøtul C 550 Options

Extended Surround Panel, Matte Black Paint	156432
Extended Surround Panel, Jøtul Iron Paint	156433
Mantel Heat Shield	156448

Appendix A

Alternate Hearth Protection

All hearth protection materials must be noncombustible; i.e. metal, brick, stone, or mineral fiber boards. Any combustible material may not be used.

Follow the procedures below to determine if a proposed alternate floor material meets requirements listed in this manual.

R-value = thermal resistance

k-value = thermal conductivity

C-value = thermal conductance

1. Convert the specification to R-value:
 - a. If r-value is given, no conversion is needed.
 - b. If k-value is given with a required thickness (T) in inches: $R = 1/k \times T$.
 - c. If C-value is given: $R = 1/C$.
2. Determine the R-value of the proposed alternate floor protector.
 - a. Use the formula in Step 1 to convert values not expressed as "R".
 - b. For multiple layers, add R-values of each layer to determine overall R-value.
 - c. If the overall R-value of the system is greater than the R-value of the specified floor protector, the alternate is acceptable.

Example:

The specified floor protector should be 3/4" thick material with a k-factor of 0.84. The proposed alternate is 4" brick with a C-factor of 1.25 over 1/8" mineral board with a k-factor of 0.29.

Step 1. Use the formula above to convert specifications to R-value. $R = 1 \times T = 1/.84 \times .75 = .893$

Step 2. Calculate R of proposed system.

- 4" brick of C = 1.25, therefore
- R brick = $1/C = 1/1.25 = 0.80$
- 1/8" mineral board of k = 0.29, therefore
- R mineral board = $1/.29 \times 0.125 = 0.431$

Total R = R brick + R mineral board = $0.8 + 0.431 = 1.231$

Step 3. Compare proposed system R = 1.231 to specified R of 0.893. Since R is greater than required, the system is acceptable.

Definitions:

Thermal conductance =

$$C = \frac{\text{Btu}}{(\text{hr})(\text{ft}^2)(\text{F})} = \frac{\text{W}}{(\text{m}^2)(\text{K})}$$

Thermal conductivity =

$$k = \frac{\text{Btu}}{(\text{hr})(\text{ft}^2)(\text{F})} = \frac{\text{W}}{(\text{m}^2)(\text{K})} = \frac{(\text{Btu})}{(\text{hr})(\text{ft})(\text{F})}$$

Thermal resistance =

$$R = \frac{(\text{ft}^2)(\text{hr})(\text{F})}{\text{Btu}} = \frac{(\text{m}^2)(\text{K})}{\text{W}}$$

Leg Leveler Installation

Two leg leveler bolts are contained within the Miscellaneous Kit included inside the firebox. The bolts are intended to help level and plumb the firebox if irregularities exist between the front and rear of the fireplace hearth.

Examine the hearth floor to determine any difference in height between the front and rear or side to side. Slide the firebox into the fireplace to confirm whether or not the leveler bolts will be necessary.

If appropriate, install the bolts through the tapped holes located in the firebox floor approximately 6" from the rear of the firebox. Adjust as necessary to achieve correct lateral level and vertical plumb.

Figure 21. Surround assembly is out of plumb because firebox is not level.

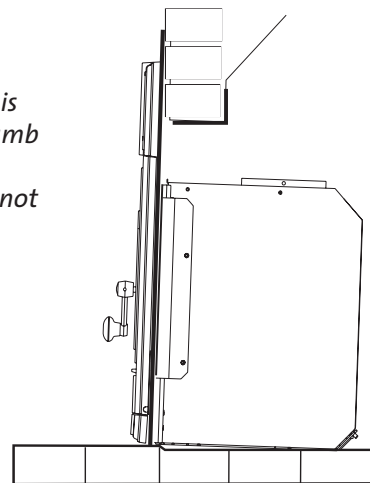
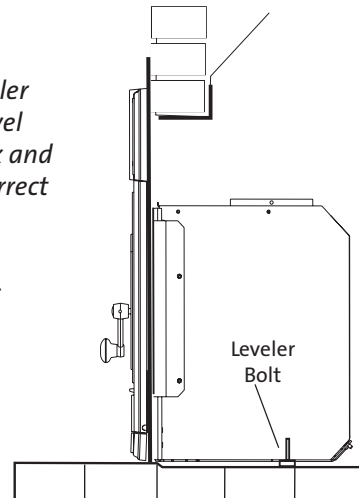

Figure 22. Install leveler bolts to level the firebox and achieve correct surround alignment.



Door Knob Installation

The Door Knob components are included in a separate bag contained within the Miscellaneous Kit included with the firebox. Install the parts in the order shown in fig. 22. Phillips screwdriver required.

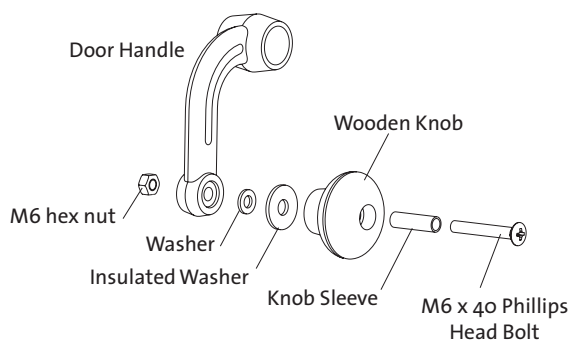

Figure 23. Door knob assembly.

Cat.no 138741-B
November, 2008

This appliance must be installed in conformance with local and national building regulations. It is important that these instructions be carefully read and understood before beginning the installation. Jøtul pursues a policy of continual product development. Consequently, products may differ in specification, color or type of accessories from those illustrated or described in various publications.

Jøtul vise sans cesse à améliorer ses produits. C'est pourquoi, il se réserve le droit de modifier les spécifications, couleurs et équipement sans avis préalable.

Jøtul North America, Inc.

55 Hutcherson Dr.
Gorham, Maine 04038
USA

Jøtul AS

P.O. Box 1411
N-1602 Fredrikstad,
Norway

