

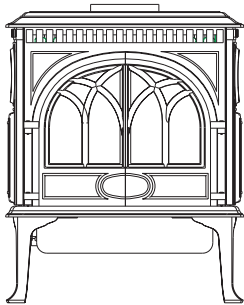

Jøtul GF 300 DV Allagash Gas Heater



Installation
and
Operation
Instructions



WARNING:

IF THE INFORMATION IN THESE INSTRUCTIONS ARE NOT FOLLOWED EXACTLY, A FIRE OR EXPLOSION MAY RESULT CAUSING PROPERTY DAMAGE, PERSONAL INJURY OR LOSS OF LIFE.

FOR YOUR SAFETY:

DO NOT STORE OR USE GASOLINE OR OTHER FLAMMABLE VAPORS AND LIQUIDS IN THE VICINITY OF THIS OR ANY OTHER APPLIANCE.

INSTALLATION:

INSTALLATION AND SERVICE MUST BE PERFORMED BY A QUALIFIED INSTALLER, SERVICE AGENCY OR LICENSED GAS SUPPLIER.

WHAT TO DO IF YOU SMELL GAS:

- **DO NOT TRY TO LIGHT ANY APPLIANCE.**
- **DO NOT TOUCH ANY ELECTRICAL SWITCHES.**
- **DO NOT USE THE PHONE IN YOUR BUILDING. IMMEDIATELY CALL YOUR GAS SUPPLIER FROM A NEIGHBOR'S PHONE.**
- **FOLLOW YOUR GAS SUPPLIER'S INSTRUCTIONS.**
- **IF YOU CANNOT REACH YOUR GAS SUPPLIER, CALL THE FIRE DEPARTMENT.**

AVERTISSEMENT:

ASSUREZ-VOUS DE BIEN SUIVRE LES INSTRUCTIONS DANS CETTE NOTICE POUR REDUIRE AU MINIMUM LE RISQUE D'INCENDIE OU POUR EVITER TOUT DOMMAGE MATERIEL, TOUTE BLESSURE OU MORTALIT'E.

NE PAS ENTREPOSER NI UTILISER D'ESSENCE NI OU LIQUIDES INFLAMMABLES DANS LE VOISINAGE DE CET APPAREIL OU DE TOUT AUTRE APPAREIL.

L'INSTALLATION LE SERVICE DOIVENT ETRE EXECUTES PAR UN INSTALLATEUR QUALIFIE, AGENCE DE SERVICE OU LE FOURNISSEUR DE GAZ.

QUE FAIRE SI VOUS SENTEZ UNE ODEUR DE GAZ.

- **NE PAS TENTER D'ALLUMER L'APPAREIL**
- **NE TOUCHEZ A AUCUN INTERRUPTEUR.**
- **NE PAS VOUS SERVIR DES TELEPHONES SE TROUVANT DANS LE BATIMENT OU VOUS VOUS TROUVEZ.**
- **APPELEZ IMMEDIATEMENT VOTRE FOURNISSEUR DE GAZ CHEZ UN VOISIN. SUIVEZ LES INSTRUCTIONS DU FOURNISSEUR.**
- **SI VOUS NE POUVEZ REJOINDRE LE FOURNISSEUR DE GAZ, APPELEZ LE SERVICE DES INCENDIES.**

Welcome to Jøtul...

Congratulations on the purchase of your new Jøtul GF 300 DV Allagash Gas Heater.

We at Jøtul are glad you've made the decision to warm your hearth with a Jøtul product. Your new GF 300 DV Allagash exemplifies our experience gained over 150 years as the world's largest manufacturer of solid fuel burning appliances. We've been making fine quality cast iron wood and coal stoves and fireplaces continuously since 1853.

The GF 300 DV Allagash combines advanced gas technology with the warm, traditional elements of cast iron. With proper care and use, your Jøtul stove will provide you with many years of safe, dependable and satisfying service.

The Jøtul GF 300 DV Allagash is a direct vented gas heater designed and approved for installation into a variety of configurations where close clearance to combustible material is required. Please take a few minutes to familiarize yourself with this manual and the features of your new Jøtul stove.

Table of Contents

| | |
|---------------------------------------|------------|
| Service Tools | 3 |
| Specifications | 4 |
| General Information | 5 |
| Safety Information | 6 |
| Installation Requirements | |
| Location | 6 |
| Hearth Protection | 6 |
| Clearances | 7 |
| Mantel & Trim | 7 |
| Alcove | 7 |
| Vent Requirements | 8 |
| Adding Restriction | 8 |
| Vertical Termination | 9 |
| Co-linear Termination | 12 |
| Coaxial Chimney Conversion | 13 |
| Horizontal Termination | 14 |
| Vent Terminal Clearances | 15 |
| Mobile Home Installation | 16 |
| Fuel Conversion | 16 |
| Gas Connection | 18 |
| Gas Pressure | 19 |
| High Altitude Adjustment | 19 |
| Air Shutter Adjustment | 20 |
| Wall Thermostat | 20 |
| Remote Control | 20 |
| Log Set Installation | 21 |
| System Check | 22 |
| Operation | 23 |
| Maintenance | 24 |
| Glass Replacement | 24 |
| Optional Blower Installation | 25 |
| Optional Brick Kit Installation | 27 |
| Illustrated Parts Breakdown | 28 |
| Replacement Parts List | 29 |
| Lighting Instructions | Back Cover |

THIS PRODUCT MUST BE INSTALLED BY A LICENSED PLUMBER OR GAS-FITTER WHEN INSTALLED IN THE COMMONWEALTH OF MASSACHUSETTS.

Jøtul GF 300 DV Direct Vent Gas Heater

Manufactured and Distributed by:
Jøtul A.S.A.
Fredrikstad, Norway
Jøtul North America
Portland, Maine

Test Standards

This appliance complies with National Safety standards and is tested and listed by Intertek Testing Services of Middleton, Wisconsin to ANSI Z21.88-2002 • CSA 2.33-M02 and CAN/CGA 2.17--M91, CSA P.4.-01.2 for Canada.



DO NOT ATTEMPT TO ALTER OR MODIFY THE CONSTRUCTION OF THE APPLIANCE OR ITS COMPONENTS. ANY MODIFICATION OR ALTERATION WILL VOID THE WARRANTY, CERTIFICATION AND LISTING OF THIS APPLIANCE.



www.nficertified.org

We at Jøtul North America are dedicated to manufacturing the finest quality hearth products you can be assured will give you many years of safe, dependable service.

To ensure your confidence, we recommend that whenever possible, our products be installed and serviced by professionals who are certified by the National Fireplace Institute (NFI) or, in Canada, by Wood Energy Technical Training (WETT).



GF 300 DV Specifications

Input Rates

Natural Gas

26,000 BTU/hr. maximum input
14,000 BTU/hr. minimum input

Propane

26,000 BTU/hr. maximum input
14,000 BTU/hr. minimum input

Inlet Pressure: MIN MAX

Natural Gas: 5.0 WC (1.24 kPa) 7.0 WC (1.74 kPa)

Propane: 12.0 WC (2.99 kPa) 14.9 WC (3.71 kPa)

Manifold Pressure: MIN MAX

Natural Gas: 1.2 WC (.30 kPa) 3.8 WC (.95 kPa)

Propane: 2.9 WC (.722 kPa) 11.0 WC (2.74 kPa)

Piezo Ignitor / Standing Pilot

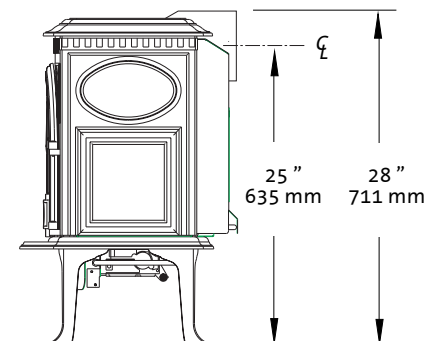
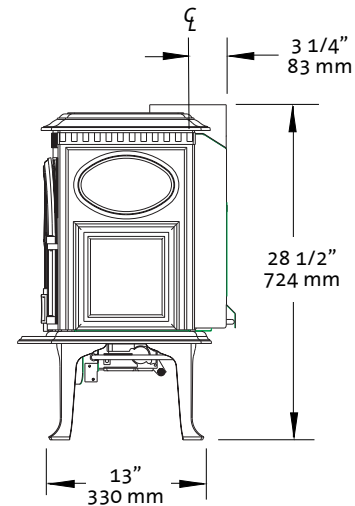
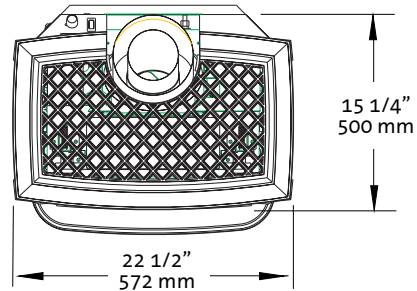
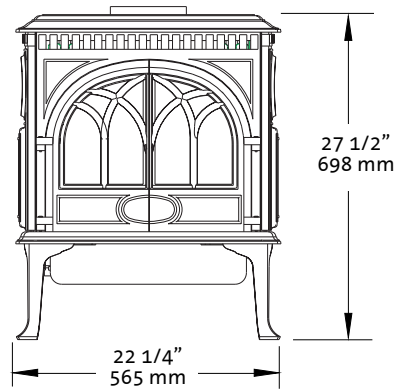

Suggested Tools for Installation and Service

- External regulator (for Propane only)
- Piping which complies with local code
- Manual shutoff valve (**T-Handle in Massachusetts**)
- Sediment trap - if required by code
- Tee joint
- Pipe wrench
- Pipe sealant
- 10 mm open end wrench
- 1/2", 7/16" open end wrench or deep socket
- Phillips head screwdriver
- Flat head screwdriver
- 1/4" nut driver
- 4 mm allen wrench
- Gloves
- Safety glasses
- Torx T20 screwdriver
- Leak test solution
- Reciprocating Saw
- Power Drill

General Information

- THIS HEATER MUST BE INSTALLED AND MAINTAINED BY A QUALIFIED SERVICE AGENCY.
- The installation and repair of this appliance must be done by a qualified service person. Failure to properly install and maintain this heater could result in an unsafe or hazardous installation, which may result in a fire, explosion, property damage, personal injury or loss of life.
- This appliance should be inspected before use and at least annually. More frequent cleaning may be required due to excessive lint from carpeting, bedding material, etc. It is imperative that control compartments, burners, and circulating air passage-ways of the appliance be kept clean.
- THIS APPLIANCE MUST NOT BE CONNECTED TO A CHIMNEY OR FLUE SERVING ANY OTHER APPLIANCE.
- The installation must conform to local codes. Your local Jøtul dealer can assist you in determining what is required in your area for a safe and legal installation. Some areas require a permit to install a gas burning appliance. Always consult your local building inspector, or authority having jurisdiction, to determine what regulations apply in your area.
- **CODE COMPLIANCE :** Your local officials have final authority in determining if a proposed installation is acceptable. Any requirement that is requested by the local authority having jurisdiction, that is not specifically addressed in this manual, defaults to local code. In the absence of local codes, the installation requirements must comply with the current edition of National codes. In the U.S., these requirements are established in the National Fuel Code, ANSI Z223.1.(NFPA 54) current edition. In Canada, the codes have been established in CAN/CGA B149 Fuel Installation Code, current edition..
- Installer l'appareil selon les codes ou reglements locaux, ou, en l'absence de tels reglements, selon les Codes d'installation CAN/CGA-B149.
- **DO NOT OPERATE THIS STOVE IF ANY PART HAS BEEN UNDER WATER.** Call a qualified service technician to inspect the heater and to replace any part of the control system and any gas control which may have been under water.
- Ne pas se servir de cet appareil s'il a été plongé dans l'eau, complètement ou en partie. Appeler un technicien qualifié pour inspecter l'appareil et remplacer toute partie du système de contrôle et toute commande qui ont été plongés dans l'eau.

Glass Panel

Do not operate this appliance with the glass front removed, cracked, or broken. Replacement of the glass should be done by a licensed or qualified service person. Only remove glass for routine service. Always handle glass carefully.

Unpacking your stove

1. Remove the Top Plate of the stove by simply lifting it straight off of the stove body.
2. To open the firebox, disengage the two Glass Frame Latches located on top of the firebox. Pull each handle forward to clear the latch from the notch in the frame.

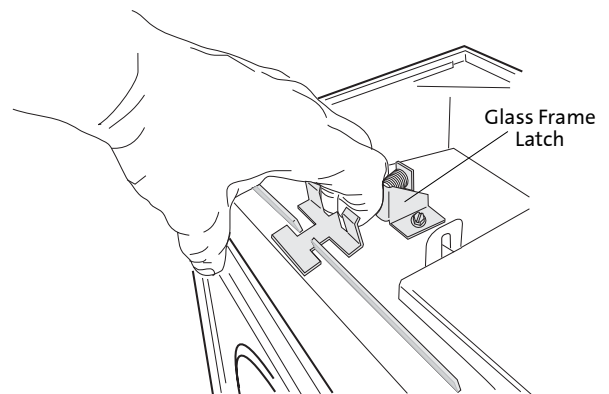

3. Familiarize yourself with the installation requirements specified in this manual, before beginning the installation.

Hardware Bag Contents

- Fuel Conversion Kit - LP 155372
- Ember Bag , 4 oz. 220702

THIS FIREPLACE IS SHIPPED FROM THE FACTORY FOR USE WITH NATURAL GAS ONLY. IF USE WITH PROPANE IS DESIRED, THE APPLIANCE MUST FIRST BE CONVERTED USING THE FUEL CONVERSION KIT PROVIDED, #155372. CONVERSION SHOULD BE MADE BEFORE THE APPLIANCE IS INSTALLED. SEE PG. 17.

Safety Information

During normal operation, the GF 300 DV gas stove will reach high surface temperatures. Therefore:

- Due to the high operating temperatures, this appliance should be located out of traffic areas and away from furniture and draperies.
- Children and adults should be alerted to the hazards of high surface temperatures and should stay away to avoid burns and/or clothing ignition.
- Young children should be supervised while they are in the same room as the GF 300 DV gas stove.
- Clothing or other flammable materials should not be placed ON or NEAR the GF 300 DV gas stove. Surveiller les enfants. Garder les vêtements, les meubles, l'essence ou autres liquides à vapeur inflammables loin de l'appareil.
- NEVER store or use gasoline or any other flammable vapors or liquids in the vicinity of the GF 300 DV gas stove.
- Never burn any other materials in your GF 300 DV Allagash gas stove, it is strictly designed for use with natural gas or propane fuel ONLY.
- Any safety screen, glass or guard removed for servicing the appliance must be replaced prior to operating the appliance.

Location

In selecting a location for the stove, consider the following points:

- 1) Heat distribution
- 2) Vent termination requirements
- 3) Gas supply line routing
- 4) Traffic areas, furniture, draperies, etc.

The GF 300 DV may be located on or near conventional construction materials, however, proper clearance to combustibles must be maintained in order to provide adequate air circulation around the appliance. Also, it is important to provide adequate access around the stove for servicing and proper operation.

The clearance and hearth specifications listed in this manual are the minimum requirements for combustible material. A combustible material is anything that can burn (i.e. sheet rock, wall paper, wood, fabrics etc.). These surfaces are not limited to those that are visible and also include materials that may be located behind non-combustibles.

If you are not sure of the combustible nature of a material, consult your local fire officials. Remember, "Fire Resistant" materials are considered combustible: they are difficult to ignite, but will burn. Also, "fire-rated" sheet rock is considered combustible.

Hearth Requirements

The GF 300 DV gas stove CANNOT be installed directly on carpeting, vinyl, linoleum or Pergo®.

If this appliance will be installed on any combustible material OTHER THAN WOOD, a floor pad must be installed that is either metal or wood, or a listed hearth pad. This floor protection must extend the full width and depth of the appliance. It is not necessary to remove carpeting, vinyl or linoleum from underneath the floor protection. See fig. 1.

Figure 1. Minimum Hearth Protection.

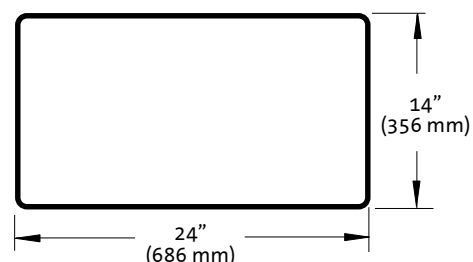

Stove and Vent Clearance Requirements

Minimum Clearances from the Stove to Combustibles:

- See figs. 2-4.
- Rear: 2" (51 mm)
 - Ceiling: 33" (838 mm)
 - Corner: 2" (51 mm)
 - Right Side: 3" (76 mm)
 - Left Side: 10" (254 mm) - for access to Lighting Instruction plate

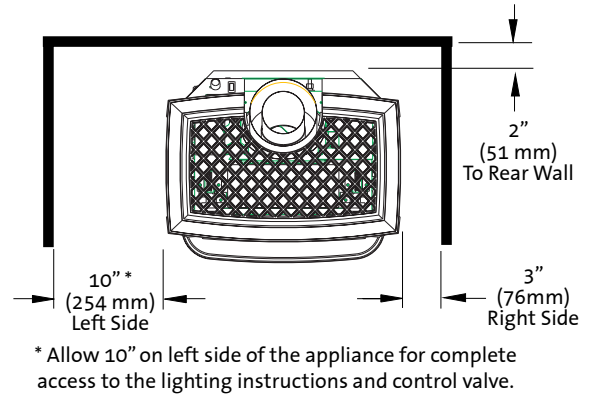

Figure 3. Parallel Installation Clearances.

Minimum Clearances from the Vent Pipe to Combustibles:

Horizontal Run:

- Off the top of the pipe 2" (50 mm)
- Off the sides and bottom 1" (25 mm)

Vertical Run:

- All sides 1" (25 mm)

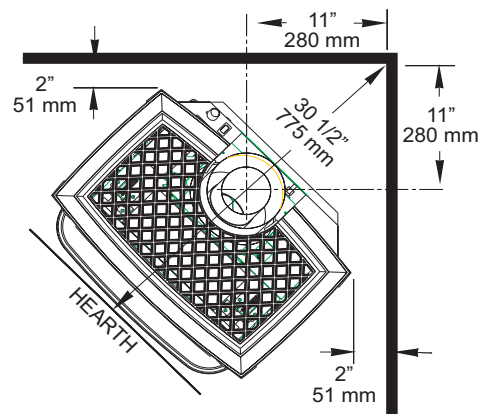

Figure 4. Vent adaptor centerline at minimum clearance to corner walls.

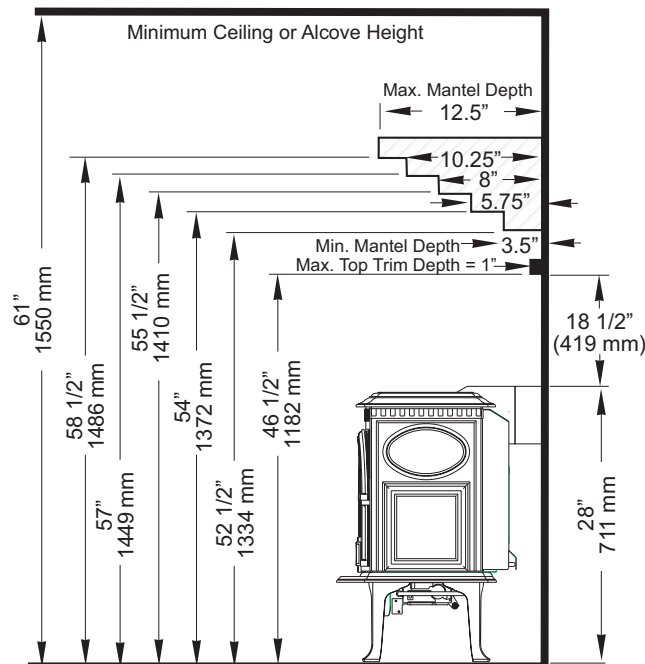

Figure 2. Mantel and Trim Clearance specifications. Subtract 2 1/4" with Short Legs.

Alcove Installation

- Maximum Alcove Depth: 24" (610 mm)
- Minimum Alcove Width: 36 3/4" (934 mm)
- Minimum Ceiling Height: 61" (1549 mm)
- With Short Legs (6"): 58 3/4" (1486 mm)

Venting Requirements

The Jøtul GF 300 DV gas stove may be installed with a vertical or horizontal termination and must conform to the configuration requirements described below.

This appliance is approved for use with vent systems from the following manufacturers:

- **Simpson Dura-Vent GS**
- **Amerivent Corporation**
- **Security Vent Ltd.**
- **Selkirk Metalbestos**

Use parts of one manufacturer only - DO NOT MIX VENT COMPONENTS FROM DIFFERENT MANUFACTURERS IN THE SAME SYSTEM.

Installation of any components not manufactured or approved by Jøtul or failure to meet all clearance requirements will void all warranties and could result in property damage, bodily injury, or serious fire.

The approved vent configurations described in this manual are derived from extensive testing under controlled laboratory conditions. Gas appliance performance can be negatively affected by variables present in the installation environment, i.e: atmospheric pressure, strong prevailing winds, adjacent structures and trees, snow accumulation, etc. These conditions should be taken into consideration by the installer and stove owner when planning the vent system design.

IMPORTANT

- **JOINT SEALING REQUIREMENT:** APPLY A 1/8" BEAD OF HIGH-TEMPERATURE (750°F) SEALANT TO THE MALE SECTION OF THE INNER VENT PIPE. THE CEMENT SHOULD FORM A SEAL BETWEEN THE INNER AND OUTER PIPES.
- NEVER MODIFY ANY VENTING COMPONENT, OR USE ANY DAMAGED VENTING PRODUCT.
- THE GAS APPLIANCE AND VENT SYSTEM MUST BE VENTED DIRECTLY TO THE OUTSIDE OF THE BUILDING AND NEVER ATTACHED TO A CHIMNEY SERVING A SOLID FUEL OR GAS BURNING APPLIANCE. EACH DIRECT VENT GAS APPLIANCE MUST HAVE ITS OWN SEPARATE VENT SYSTEM. COMMON VENT SYSTEMS ARE PROHIBITED.
- IF VENTING SYSTEM IS DISASSEMBLED FOR ANY REASON, REINSTALL PER THE INSTRUCTIONS PROVIDED FOR THE INITIAL INSTALLATION.

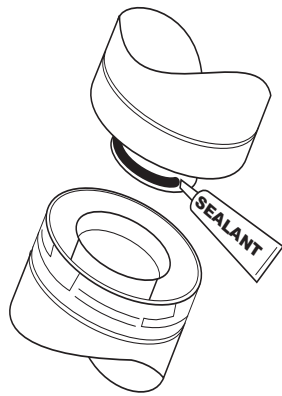

Figure 5.

Vent Restriction

The GF 300 DV is equipped with an Exhaust Restrictor Plate which enables you to regulate the flow of exhaust gas. The plate prevents overly strong draft that can cause poor combustion and weak flame picture. **Follow the guidelines below, and on the following pages, to determine the correct restrictor plate setting for your particular installation configuration.**

Exhaust Restrictor

The Exhaust Restrictor is an adjustable shutter located at the top right side of the firebox. It is adjusted by moving a pivot pin into one of four positions. It is set in the **FULLY OPEN (D)** position at the factory. See Fig. 7. The four positions correlate to the termination zones (A,B,C,D) diagrammed in figures 9-12. Consult these Vent Window diagrams on pages 10-11 to determine the setting you should use.

Additional restriction may be needed depending the overall vent height. If necessary, use Simpson Dura-Vent Restrictor Disk #929.

Adjusting Exhaust Restrictor Plate:

1. Use the Vent Window diagrams to determine which setting position to use.
2. Remove the Top Plate.
3. Locate the pivot pin at the right side of the firebox top. Use a 7 mm or 9/32 nut driver to loosen the nut on the pivot pin and then push the pin to the left to disengage it from the current factory-set position. Move the pin forward and into the slot appropriate for your specific vent configuration. See figs. 6 and 7.
4. Tighten the lock nut and replace the Top Plate.

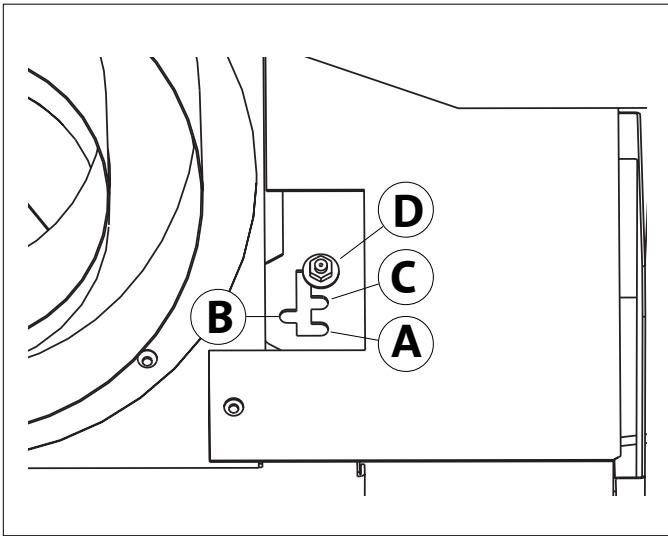

Figure 6. Exhaust restrictor positions - viewed from front with top plate removed.

Vertical Vent Termination

The Jøtul GF 300 DV can be vertically vented through a ceiling or to a roof termination with the following guidelines:

- The termination should fall within the shaded areas of the grids depicted in the Vent Window diagrams on pages 10 - 11.
- **Maximum Vertical** run should not exceed **35 ft.** (10.66 m).
- **Minimum Vertical** run must be at least **8 ft.** (2.43 m).
- **Max. Colinear Horizontal run is 2 ft.** (61 cm).
- **Vent Terminus Clearance:** In no case shall any discharge opening on the cap be less than 18 in. (610 mm) horizontally from the roof surface.
- Steep roofs, nearby trees, and predominantly windy conditions can contribute to poor draft and/or promote down-draft occurrences. Increasing the height of the vent may alleviate these conditions.
- Use Wall Straps to support an offset pipe run at three feet intervals to avoid excessive stress on the offsets.
- **Elbows:** Four 45°, or two 90° elbows may be used. Do not include the 45° elbow attached to the stove. Whenever possible use 45° elbows instead of 90° elbows as they are less restrictive to exhaust gas and intake air flow.
- A firestop is required at every floor. The opening should be framed to 10" X 10" inside dimension.
- Any venting that is exposed above the first floor, regardless of attic space or living space, must be enclosed. Always maintain the required 1" clearance from all sides of the vertical vent system.

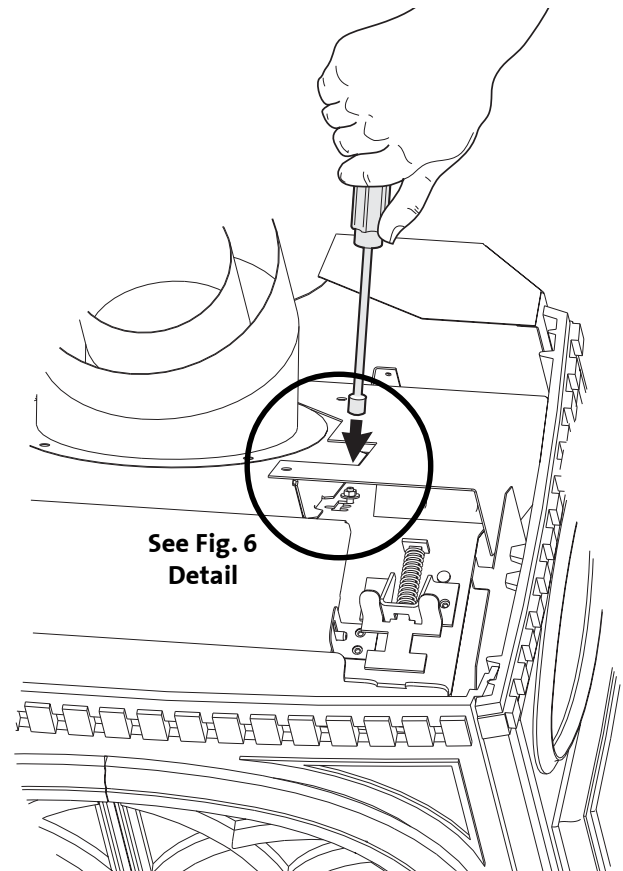

Figure 7. Use a nut driver to change the Exhaust Restrictor setting.

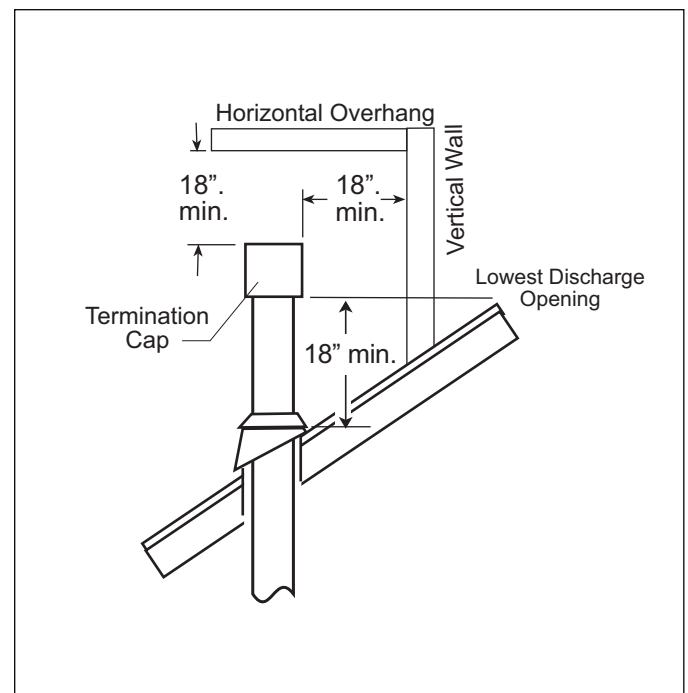

Figure 8. Vertical vent termination height above roof.

Vent Windows for Natural Gas

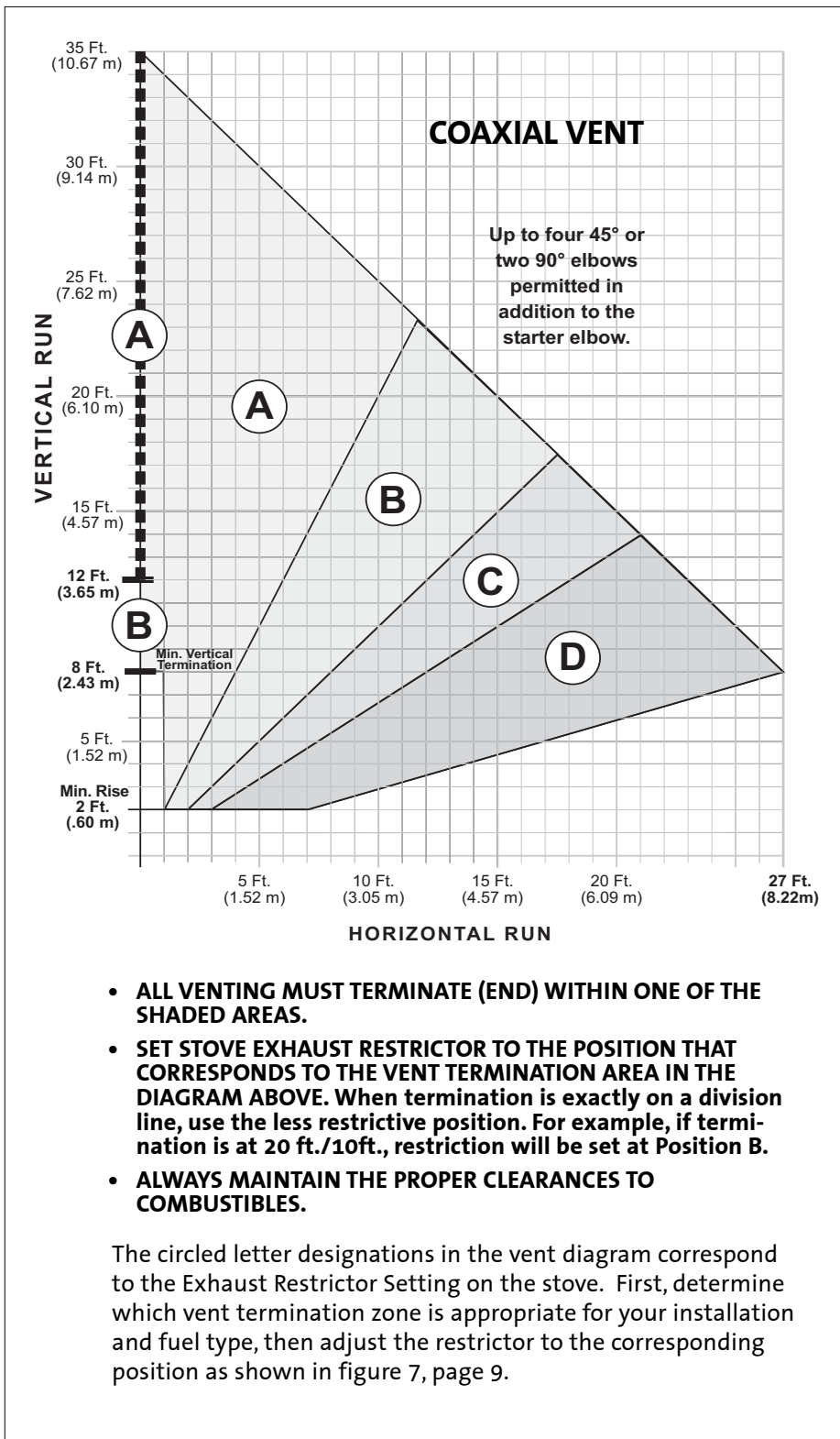

Figure 9. Coaxial Vent Termination Window / NG

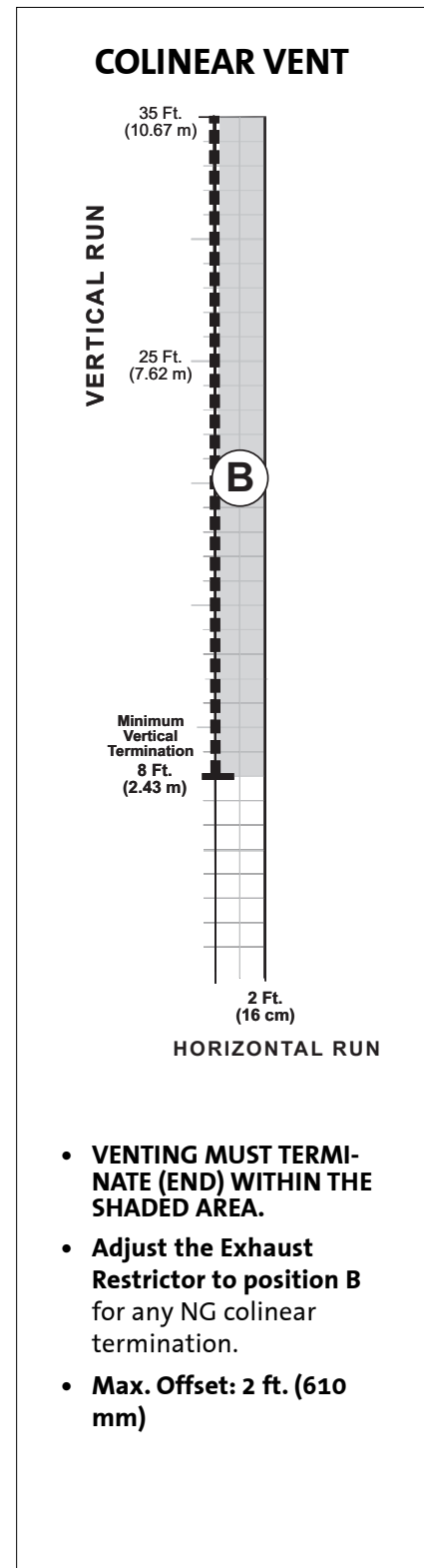

Figure 10. Colinear Termination / NG

Vent Windows for Propane

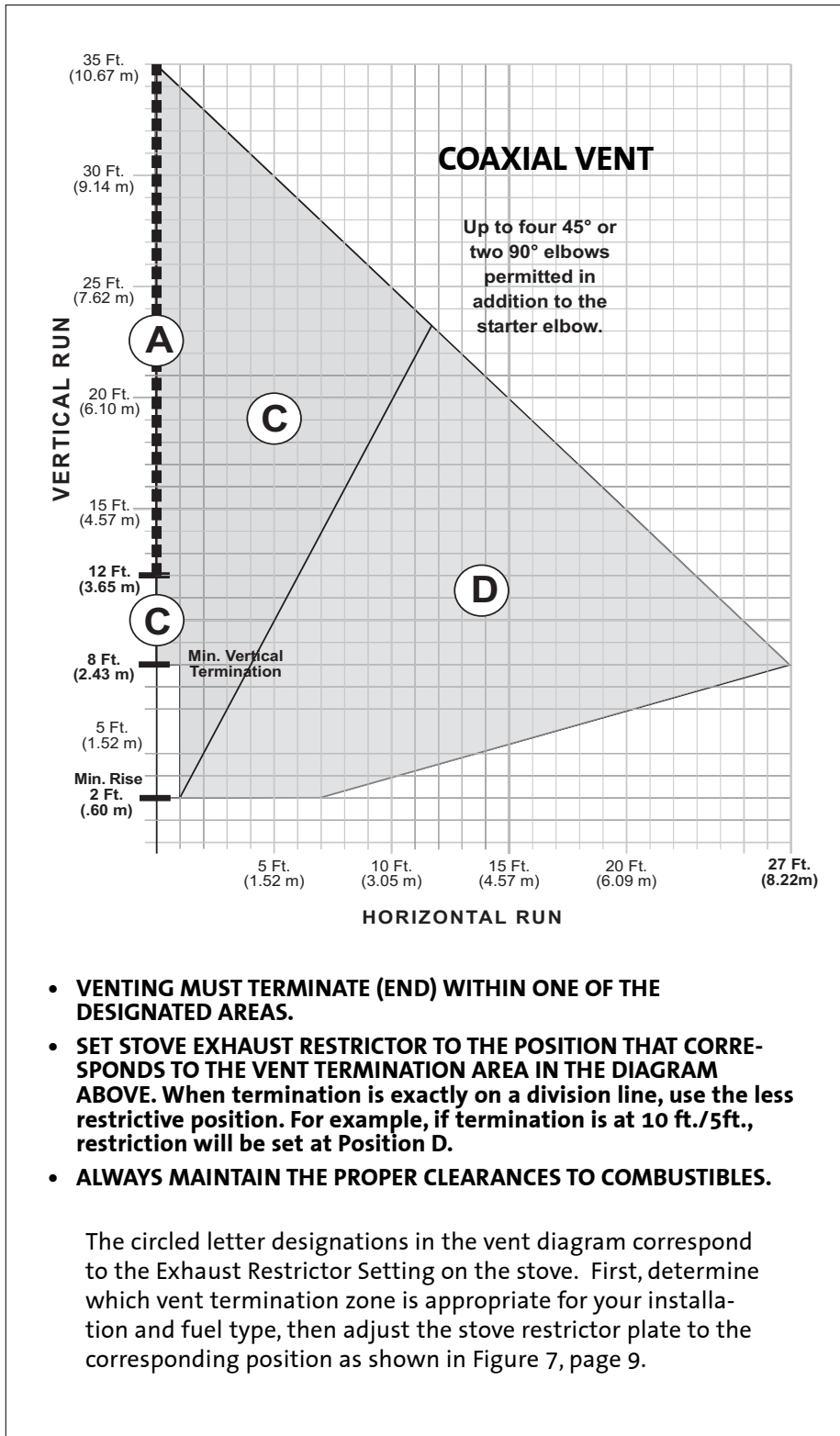

Figure 11. Coaxial Vent Termination Window / LP

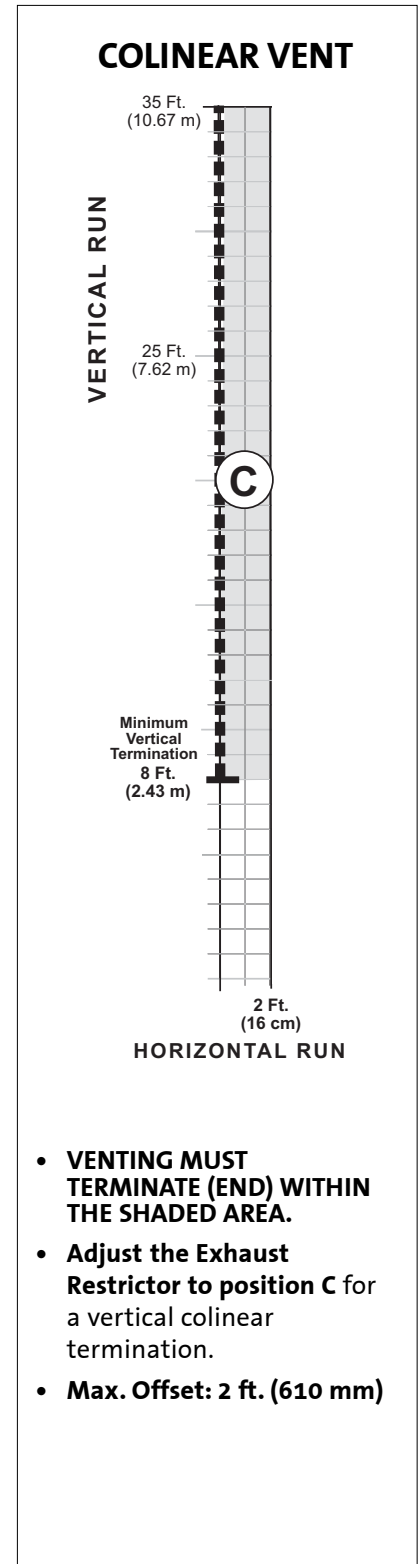

Figure 12. Colinear Termination / LP

Co-linear Vent Installation

The GF 300 DV may be vented through a masonry or Class A prefabricated chimney using a Co-linear Flexible Vent system approved for use with a solid-fuel burning fireplace. When installed in the manner described below, this system can improve the performance of the appliance in cold climate situations, as well as simplify the vent installation. See fig. 14.

These installation requirements must be followed:

1. Use the guidelines for Co-linear Vent Termination appropriate for your gas type on pages 10 - 11.

1. Prior to the installation the chimney flue must be thoroughly cleaned and inspected by a qualified chimney service person.
2. In a masonry chimney, a fireclay liner must be present the entire length of the chimney.
3. Prefabricated chimneys must be UL 103 or ULC S-629 listed and have a minimum INSIDE diameter of 6 inches, (150 mm).
4. No appliance can be installed into a chimney flue serving any other appliance of any kind.
5. **THE AIR INTAKE FLEX PIPE MUST EXTEND 6 FEET BEYOND THE DAMPER AREA OF THE FIREPLACE.**
6. If the intake flex duct does not extend the full length of the chimney and connect to both the unit and the termination cap, A METAL BLOCK OFF PLATE MUST BE CONSTRUCTED AND INSTALLED ABOVE THE UNIT PRIOR TO THE END OF THE INTAKE FLEX AND MUST COMPLETELY SEAL THE CHIMNEY FLUE FROM THE ROOM.

Consult with the local code authority having jurisdiction before proceeding with this type of installation.

Refer to the vent manufacturer's instructions for specific installation requirements.

WARNING: FAILURE TO POSITION THE PARTS AND STOVE IN ACCORDANCE WITH THESE DIAGRAMS OR FAILURE TO USE ONLY PARTS SPECIFICALLY APPROVED FOR USE WITH THIS APPLIANCE MAY RESULT IN PROPERTY DAMAGE OR PERSONAL INJURY. BE SURE TO MAINTAIN THE PROPER CLEARANCES TO COMBUSTIBLES AS DEFINED IN THIS MANUAL AND IN THE INSTRUCTIONS PROVIDED WITH EACH VENT COMPONENT.

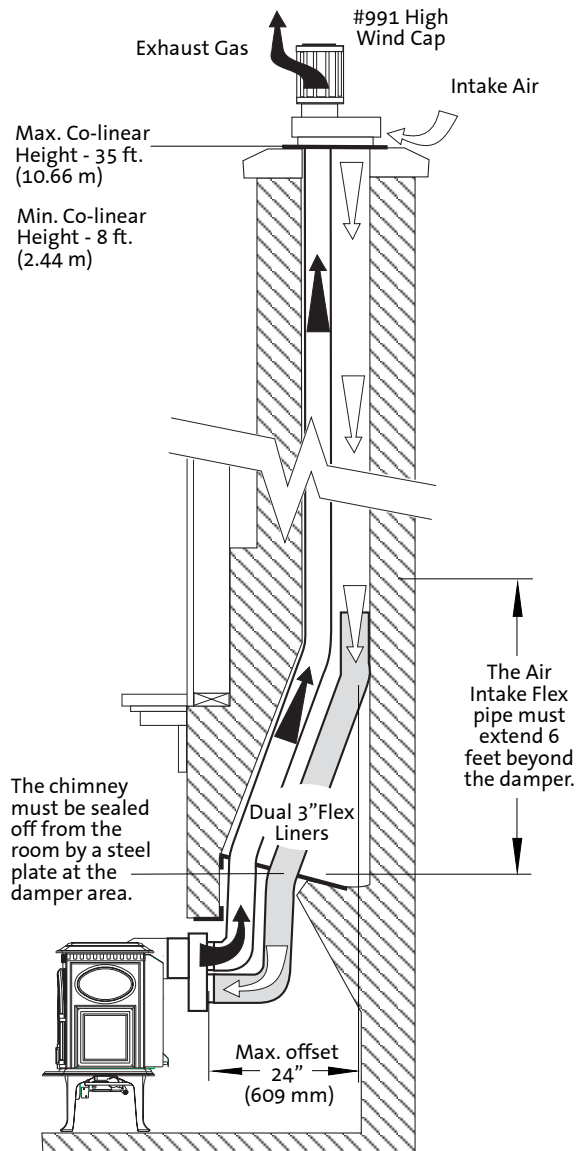

Figure 14. Co-linear Adaptor installed through a masonry chimney. Simpson Dura-Vent components shown.

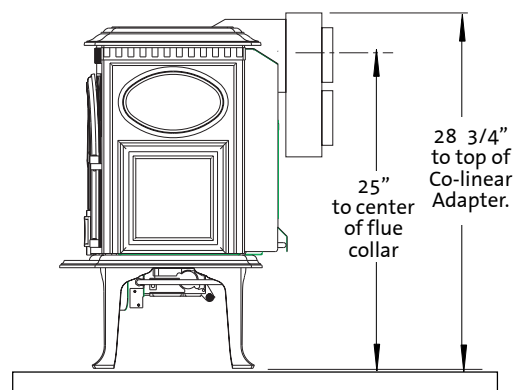

Figure 15. Simpson Dura-Vent #923GCL Co-linear Adaptor. Subtract 2 1/4" for Short Legs.

Masonry or Prefabricated Chimney Conversion

The GF 300 DV is approved for use with Simpson Dura-vent Chimney Kit #934 in a masonry chimney or a prefabricated solid fuel listed chimney.

These installation requirements must be followed:

1. Use the guidelines for Coaxial Vent Termination appropriate for your gas type on pages 11 - 12.
2. In masonry chimney, a fireclay liner or listed steel liner, must be present the entire length of the chimney.
3. Chimney height should not exceed 35 ft. (10.67 m).
4. The liner must have an inside dimension of 6" round or greater. (USE KIT #934)
5. Prefabricated chimneys must be UL 103 or ULC S-629 listed and have a minimum INSIDE diameter of 6 inches, (150 mm). Prefabricated chimneys must be listed for the specific Simpson Dura-Vent Chimney Conversion Kit. (USE KIT #931, #932, or #933)

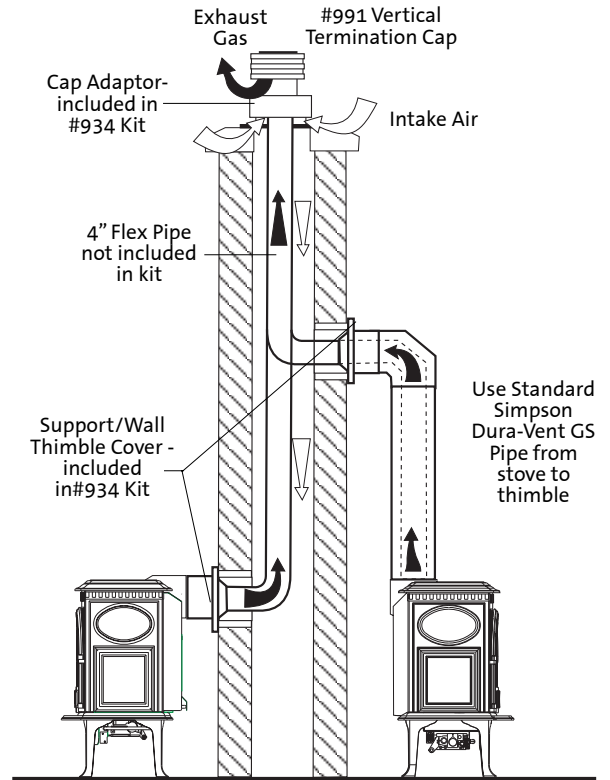

Figure 16. Vent System through a masonry chimney using the Simpson Dura-Vent Chimney Conversion Kit #934. May also be used in listed prefabricated chimneys. Drawing is for illustrative purposes only - DO NOT VENT TWO APPLIANCES INTO A SINGLE CHIMNEY.

IMPORTANT NOTICE

THE USE OF AN EXISTING CHIMNEY AS AN AIR INTAKE IS NOT COVERED UNDER THE ANSI Z21.88-1999-CSA 2.33-M99 TEST METHODS AND RESULTING ITS/WHI PRODUCT CERTIFICATION. THE CODE AUTHORITY HAVING JURISDICTION MUST BE CONSULTED PRIOR TO PROCEEDING WITH THIS INSTALLATION METHOD.

Horizontal Termination

- Any horizontal termination must fall within the shaded portion of the vent window graph illustrated in figs. 9 or 11. For Snorkel Terminations, see below.
- Any horizontal termination except a snorkel termination, must include:
 - 1) **Minimum rise of 24 in.**
 - 2) **Minimum horizontal run of 12 in. when vertical run is less than 8 ft.**
 - 3) **Vertical run no more than 35 ft.**
 - 4) **Horizontal run no more than 27 ft.**
 - 5) No more than four 45° or two 90° Elbows
- The horizontal termination cap must maintain a 3" clearance to any overhead combustible projections 2 1/2" or less. It must also maintain 12" clearance from projections exceeding 2 1/2". See fig. 21.
- Wall Cut-out Opening: A minimum 10" X 10" (250 mm X 250 mm) square hole is required for proper pipe clearances through a combustible wall.

DO NOT FILL AIR SPACE WITH ANY TYPE OF INSULATION.

- Any horizontal run of vent must be level or have a 1/4 in. rise for every foot of run toward the termination cap. NEVER ALLOW THE VENTING TO RUN DOWNWARD FROM STOVE TO TERMINATION; DOWNWARD VENT RUNS TRAP HEAT AND CAUSE HIGH TEMPERATURES TO DEVELOP WITHIN THE VENT THAT COULD START A FIRE.
- Install a Vinyl Siding Standoff (Simpson Dura-Vent #950) between the vent termination and an exterior wall covered by vinyl siding material to prevent potential heat damage to the siding.
- Do not recess the termination cap into a wall or siding.

Snorkel Terminations

- **With a 14" Snorkel:**
The horizontal run made directly off the rear of the stove into a 14" snorkel cap should include no more than a single 12" straight section as shown in fig. 17. One 45° Elbow may be used for a corner installation as shown in fig. 19.
- **With a 36" Snorkel:**
The maximum horizontal run may be no more than 6 ft. (182 cm.)
- **Exhaust Restriction:** Under normal circumstances, no exhaust restriction is recommended. Keep the factory setting (Position D - fully open).

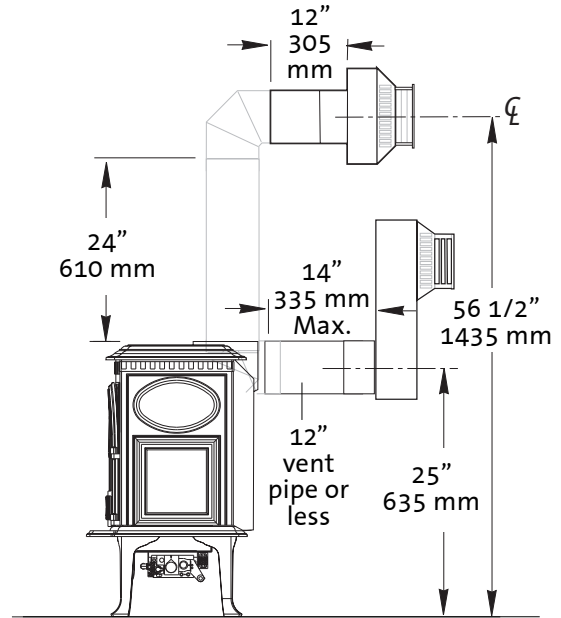

Figure 17.

- Minimum vent for horizontal termination.
- 14" Maximum horizontal run directly off rear of stove with 14" Snorkel termination.

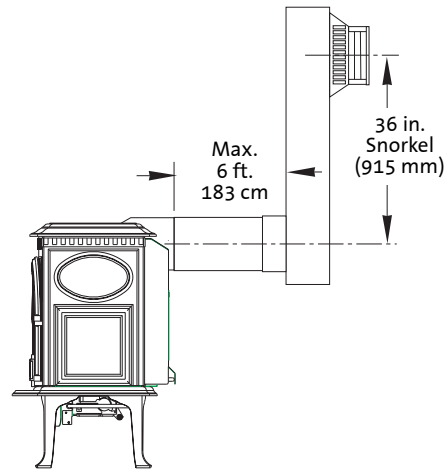

Figure 18. Maximum Horizontal with 36" Snorkel Termination.

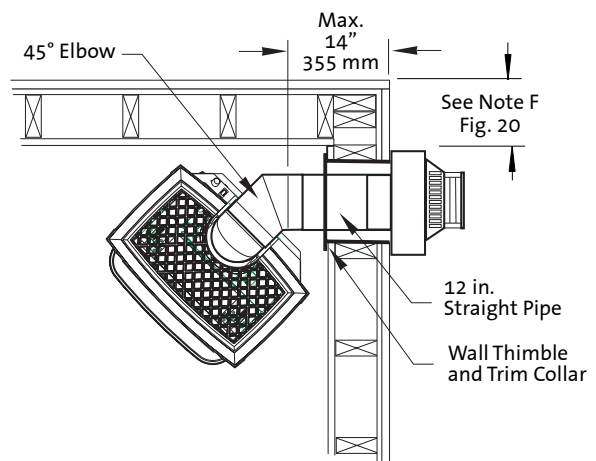

Figure 19. Corner Installation with 14" Snorkel Termination.

Horizontal Termination Clearance

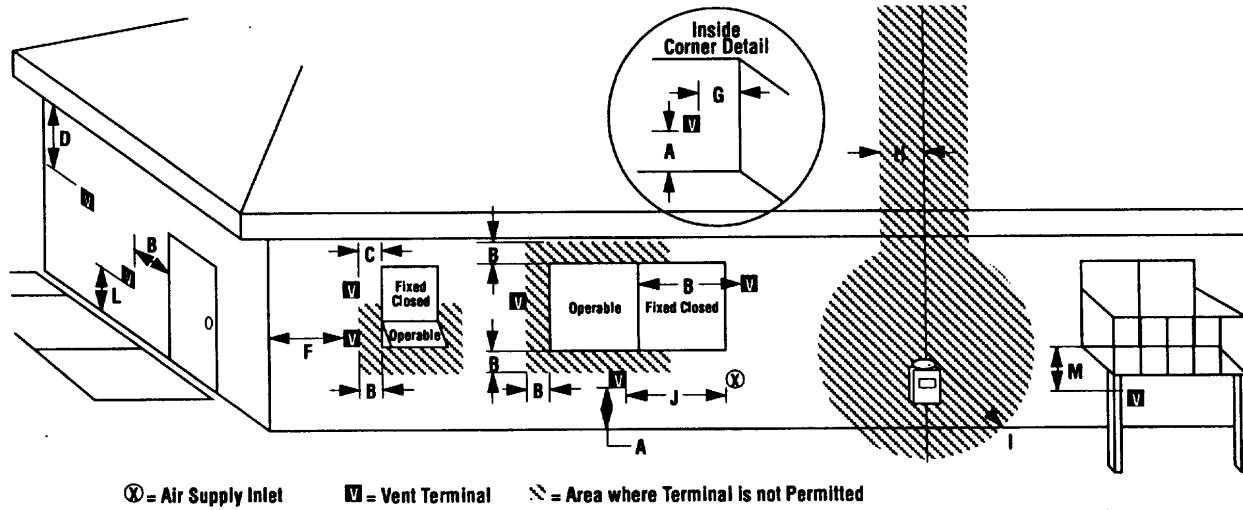

Figure 20. Vent Terminal Clearances - National Fuel Gas Code.

A = Clearance above grade, veranda, porch, deck, or balcony :
***12 inches (30 cm) minimum.**

B = Clearance to window or door that may be opened: **9 inches (23 cm) min./U.S. *12 inches (30 cm) min./ CAN**
 We recommend 12 inches minimum to help prevent condensation on the window.

C = Clearance to permanently closed window: **9 inches (23 cm) min./U.S. *12 inches (30 cm) min./ CAN**
 We recommend 12 inches minimum to help prevent condensation on the window.

D = Vertical clearance to ventilated soffit located above the terminal within a horizontal distance of 2 feet (60 cm) from the centerline of the terminal: **18 inches (46 cm) minimum.**

E = Clearance to unventilated soffit: **12 inches (46 cm) minimum.**

F = Clearance to outside corner: **9 inches (23 cm) min.** Jøtul N.A. strongly recommends 12 inches (30 cm), particularly where windy conditions are prevalent.

G = Clearance to inside corner: **6 inches (16 cm) minimum.**
 Jøtul N.A. strongly recommends 12 inches (30 cm), particularly where windy conditions are prevalent.

H = *Not to be installed above a meter/regulator assembly **within 3 feet (90 cm)** horizontally from the centerline of the regulator.

I = Clearance to service regulator vent outlet: **U.S. - 3 feet CAN. 6 feet (1.8 m) minimum.**

J = Clearance to nonmechanical air supply inlet to building or the combustion air inlet to any other appliance: ***12 inches (30 cm) minimum.**

K = Clearance to a mechanical air supply inlet: ***6 feet (1.8 m) minimum.**

L = ** Clearance above paved sidewalk or a paved driveway located on public property: ***7 feet (2.1 m) min.**

M = Clearance under veranda, porch, deck, or balcony: ***12 inches (30 cm) minimum.¹**

* As specified in CGA B149 Installation Codes. Note: Local Codes and Regulations may require different clearances.

** A vent shall not terminate directly above a sidewalk or driveway which is located between two single family dwellings and serves both dwellings.*

¹ Only permitted if veranda, porch, deck, or balcony, is fully open on a minimum of two sides beneath the floor.*

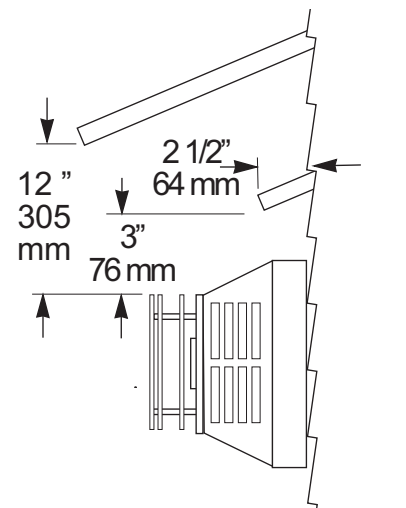

Figure 21. Termination Clearance to overhangs.

Mobile Home Installation

The GF 300 DV can be installed for use in a mobile home in the U.S. and Canada provided:

1. The stove is secured to the floor of the mobile home. Use Jøtul Floor Bracket Kit #154388.
2. Provision must be made to secure an electrical ground between the stove and the mobile home chassis.
3. The stove is installed in accordance with Title 24 CFR, Part 3280- Manufactured Home Construction and Safety Standard, in the U.S. In Canada, comply with CSA Z240.4, Gas Equipped Recreational Vehicles and Mobile Housing.
4. Always contact your local officials about installation restrictions and requirements in your area.

THIS APPLIANCE MAY BE INSTALLED AS AN OEM INSTALLATION IN A MANUFACTURED (MOBILE) HOME AND MUST BE INSTALLED IN ACCORDANCE WITH THE MANUFACTURER'S INSTRUCTIONS AND THE MANUFACTURED HOME CONSTRUCTION AND SAFETY STANDARD, TITLE 24 CFR, PART 3280. THIS APPLIANCE IS ONLY FOR USE WITH THE TYPE OF GAS THAT IS INDICATED ON THE STOVE'S RATING PLATE. A GAS CONVERSION KIT IS PROVIDED WITH THE GF 300 DV GAS STOVE.

THIS APPLIANCE MAY BE INSTALLED IN AN AFTERMARKET PERMANENTLY LOCATED, MANUFACTURED (MOBILE) HOME, WHERE NOT PROHIBITED BY LOCAL CODES.

CET APPAREIL PEUT ETRE INSTALLE DANS UN MAISON PREFABRIQUEE (MOBILE) DEJA INSTALLEE A DEMEURE SI LES REGLEMENTS LOCAUX LE PERMETTENT. CET APPAREIL DOIT ETRE UTILISE UNIQUEMENT AVEC LES TYPES DE GAS INDIQUES SUR LA PLAQUE SIGNALÉTIQUE. NE PAS L'UTILISER AVEC D'AUTRES GAS SAUF SI UN KIT DE CONVERSION CERTIFIE EST INSTALLE.

Fuel Conversion

The GF 300 DV gas stove is shipped from the factory equipped to burn NATURAL GAS only. If PROPANE gas is to be used as fuel, the appliance must first be converted for use with propane. Use Propane Conversion Kit 155372, supplied with the appliance.

Order and install NG Conversion Kit 155373 to change back to use with natural gas.

WARNING:

THE CONVERSION KIT IS TO BE INSTALLED BY AN AUTHORIZED JØTUL SERVICE TECHNICIAN IN ACCORDANCE WITH THE MANUFACTURER'S INSTRUCTION AND ALL CODES AND REQUIREMENTS OF THE AUTHORITY HAVING JURISDICTION. FAILURE TO FOLLOW THESE INSTRUCTIONS COULD RESULT IN SERIOUS INJURY OR PROPERTY DAMAGE. THE QUALIFIED AGENCY PERFORMING THIS WORK ASSUMES RESPONSIBILITY FOR THIS CONVERSION.

IN CANADA:

THE CONVERSION SHALL BE CARRIED OUT IN ACCORDANCE WITH THE REQUIREMENTS OF THE PROVINCIAL AUTHORITIES HAVING JURISDICTION AND IN ACCORDANCE WITH THE REQUIREMENTS OF THE CAN1-B149.1 AND .2 INSTALLATION CODE.

Tools required:

- 1/2" open ended wrench or deep-well socket, Torx T20 or slotted screwdriver, 4 mm allen wrench.

Conversion Kit Contents:

- 1, regulator tower labeled for propane
- 3, regulator tower screws
- 1, burner orifice (#39 for NG, #53 for LPG)
- 1, pilot orifice (#51 for NG, #30 for LPG)
- Label A - to be completed and applied to the back of the stove
- Label B - apply to the stove's Rating Plate
- Small valve label - apply to valve body

Conversion instructions are also shipped in the stove with the conversion kit.

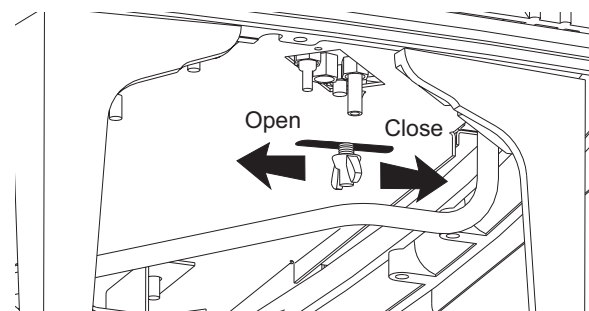

Figure 22. Locate and remove the Air Shutter wingnut from under the right side of the stove.

Fuel Conversion Procedure

1. Turn off gas supply to stove.
2. Remove the stove Top Plate.
3. Disengage the two Glass Frame Latches at the top of the firebox. See illustration on page 5. Carefully lift the glass panel up and out of the stove.
4. If installed, remove the Embers and Log Set using care not to damage the fragile log parts.
5. Lift out the Burner Skirt- (Part 40, fig. 52 p.28).
6. Reach under the stove and remove the Air Shutter wingnut from its stud. As you face the right side, it is the one closest to you. See fig. 22.
7. Lift out the Burner Plate: NOTE: There are no screws securing the Burner to the floor of the firebox. Pull the Air Shutter forward and lift the burner together with shutter up and out of the stove as a unit. See fig. 23.
8. Change the Main Burner Orifice. See fig. 24. Using a $\frac{1}{2}$ " open ended wrench or deep-well socket remove the burner orifice from its brass elbow housing and replace with the appropriate orifice supplied in the kit. While removing the orifice, use an adjustable wrench to counter-lock the orifice elbow at the back of the firebox as shown in fig. 24a.
9. Replace the Air Shutter with its gasket and push it all the way back to allow replacement of the Burner Plate. Reattach the wingnut to the shutter stem under the stove, but do not tighten. You will set its final position later.
10. Replace the Burner Plate. Engage the burner tube with the Air Shutter assembly as in fig. 25. Be sure the burner is securely engaged with the two support brackets at the front of the firebox and push the plate back toward the rear of the firebox. When correctly positioned, there will be $\frac{1}{2}$ " (13 mm) clearance between the burner plate and the front of the firebox. See fig. 25.
11. **CHANGE THE PILOT ORIFICE: From within the firebox, remove the Pilot Head by pulling it straight up from the pilot base.** See fig. 26. Using the 4 mm hex key included with the kit, unscrew the pilot orifice (counter-clockwise). Replace with the appropriate orifice:
12. Tighten orifice into the base of the pilot assembly. To prevent bypass leaks, be sure the orifice is secured tightly and flush with the base. Replace pilot head by pushing it down onto the pilot base.
13. **Replace the Variable Regulator.** Using a Torx T-20 screwdriver, remove the three screws from the front of the valve regulator. See fig. 27.
14. Remove the Regulator Tower, Gasket, white plastic disk, and Spring. Remove the black rubber gasket from the valve. See fig. 27.

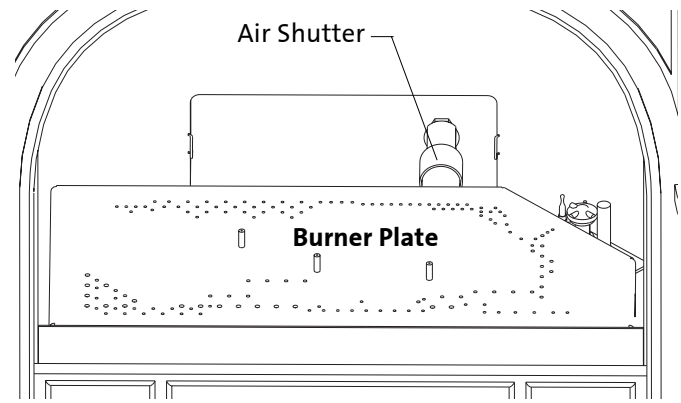

Figure 23. Remove the Air Shutter and Burner as a unit.

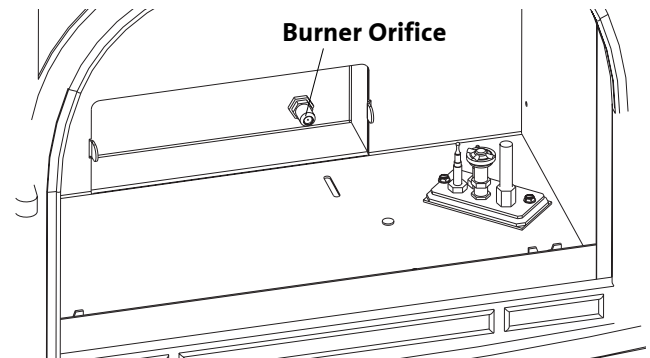

Figure 24. Change the Burner Orifice.

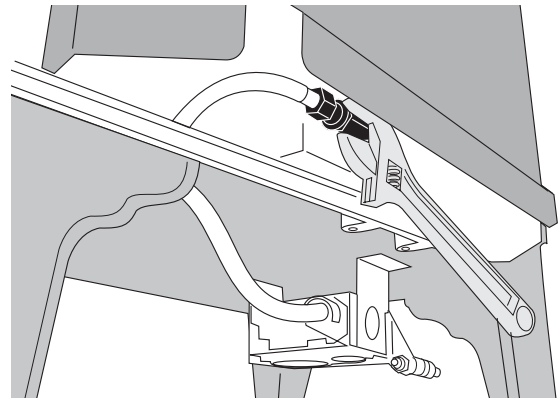

Figure 24a. Counter-lock the orifice elbow while removing the burner orifice.

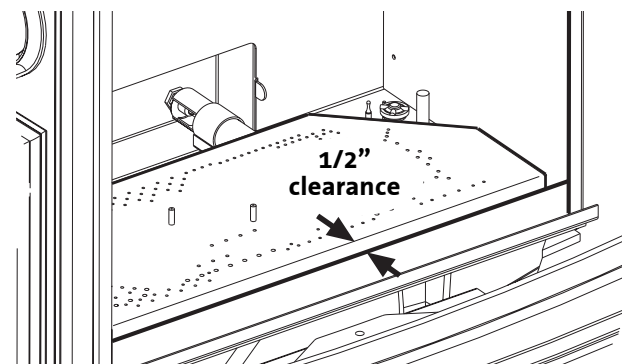

Figure 25. Correct Burner Position.

15. **Install the new regulator:** Be sure the new gasket is properly positioned and tighten screws securely.
16. Install the identification labels to the stove so that they can be seen by any person that may be servicing the stove.
Label A: apply to back of stove.
Label B: apply to the rating plate attached to the back of the stove.
Small Valve Label: apply to valve.
17. Reassemble the stove, apply gas to the system and check for leaks using a soapy water solution.

NEVER USE AN OPEN FLAME TO CHECK FOR GAS LEAKS.

18. Correct gas pressure is essential for efficient and safe operation of this appliance. Use a manometer to check pressures as specified in the Gas Pressure section of this manual (page 19).
19. **Adjust the Air Shutter.** You will need to position the shutter to provide a gas/air mixture that will achieve the best flame picture with your particular installation. Start with the shutter stem at the half-way position in the slot in the bottom of the stove. See figs. 22 and 25. Pushing the stem back will restrict air, while pushing it forward will open the shutter and increase air. With some experimentation, you will find the shutter position that works best for your installation.

ALWAYS REFER TO THE LIGHTING INSTRUCTIONS ON THE INSIDE BACK COVER OF THIS MANUAL WHEN LIGHTING YOUR STOVE.

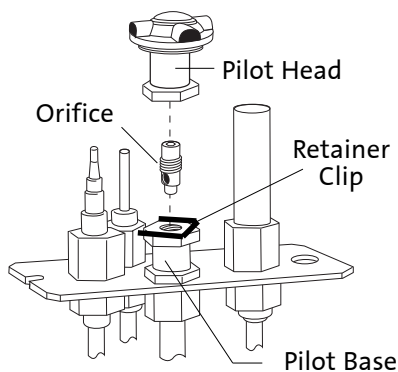

Figure 26. Pilot orifice removal and replacement.

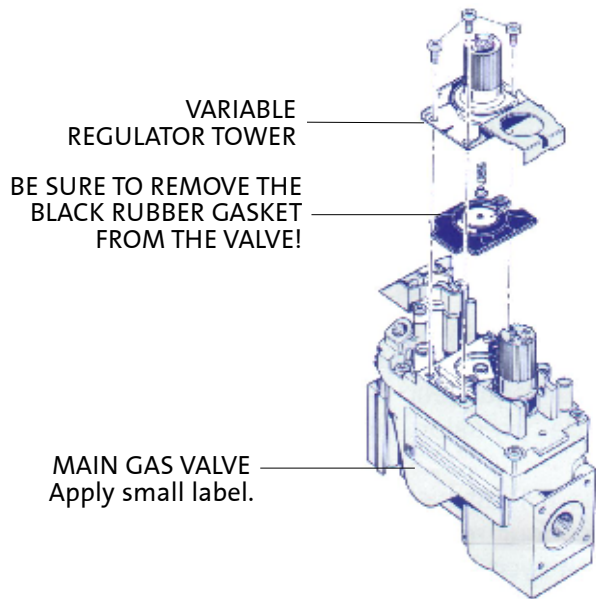

Figure 27. Regulator assembly.

Gas Supply Connection

BLOWER NOTE: Install a 90° elbow off the valve to allow clearance for installation of the optional blower.

The gas supply line connection is made to the valve just inside the left rear leg. The gas supply line should be 3/8" npt with a 1/2" diameter supply, or the appropriate size to provide sufficient gas pressure to the valve regardless of the input setting.

The use of Flexible Gas Appliance Connectors is acceptable in many areas in the U.S. However, Canadian methods vary depending on local code.

ALL INSTALLATIONS MUST COMPLY WITH LOCAL CODE OR IN THE ABSENCE OF LOCAL CODE, MUST COMPLY WITH THE MOST RECENT EDITION OF THE NATIONAL FUEL GAS CODE ANSI Z223.1/NFPA 54 OR CAN-B149.

All codes require a gas shut-off valve (gas cock) and union, to be installed in the supply line, and in the same room as the appliance. This allows for the disconnection of the stove for servicing and maintenance. See fig. 28.

A T-HANDLE GAS COCK IS REQUIRED IN MASSACHUSETTS TO COMPLY WITH CODE 248CMR.

Secure all joints tightly using appropriate tools and sealing compounds. For propane units be sure to use compounds that are propane resistant. Turn on gas supply and test for gas leaks using a soapy water solution. Never use an open flame to check for leaks.

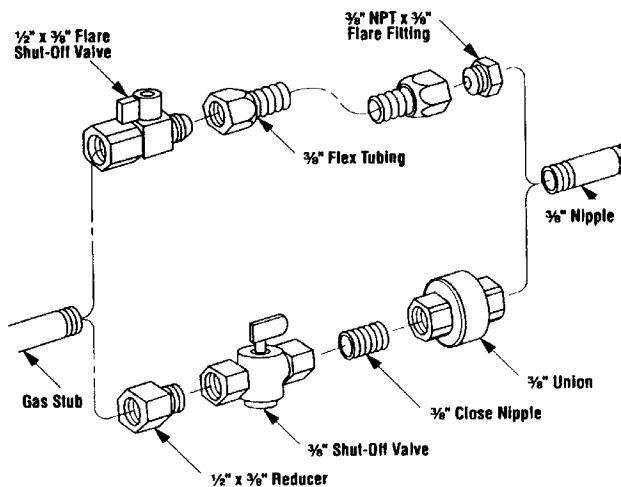

Figure 28. Supply valve connection fittings.

Leak test:

1. Mix a 50-50 solution of water and dish soap.
2. Light appliance- see lighting instructions on the inside back cover of this manual or on the stove's rating plate.
3. Brush or spray all joints and connections with the soapy water solution.
4. If bubbles appear at any connection or seam or a gas odor is detected, immediately turn gas control knob to the OFF position.
5. Tighten or reconnect the leaking joint and retest for any gas leaks.

Gas Pressure

Correct gas pressure is essential for efficient and safe operation of the GF 300 DV gas stove. It is important that the correct pressure is established at the time of the installation. Proper gas pressure provides a consistent flow of gas to the appliance and is instrumental in checking for gas leaks.

Pressure Test: Attach a manometer to the appropriate test point on the valve. See fig. 29. The gauge connections are located on the front of the valve under the On/Off/Pilot- knob. Gauge connections are identified by:

E - for **Inlet** or **Supply Pressure** (the amount of gas coming to the valve.)

A - for **Manifold Pressure** (the amount of gas that is coming out of the valve to the burner.)

ALWAYS TEST PRESSURES WITH VALVE CONTROL KNOB SET ON HIGH.

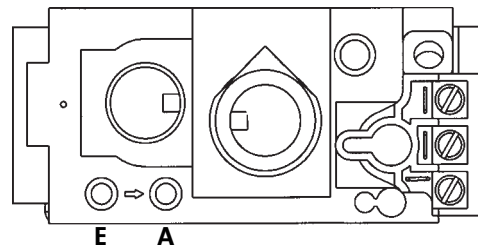

Figure 29. Pressure test points.

INLET GAS PRESSURES
(inches water column)

| | <u>MIN</u> | <u>MAX</u> |
|-------------|------------|------------|
| NATURAL GAS | 5.0 | 7.0 |
| PROPANE | 12.0 | 14.9 |

The appliance and its appliance main gas valve must be disconnected from the gas supply piping system during any pressure testing on that system at test pressures in excess of 1/2 psig (3.5 kPa).

The appliance must be isolated from the gas supply line by closing its individual manual gas shut-off valve (gas cock) during any pressure testing of the gas supply piping system that is equal to or exceeds pressures of 1/2 psig (3.5 kPa).

MANIFOLD PRESSURES
(inches water column)

| | <u>MIN</u> | <u>MAX</u> |
|-------------|------------|------------|
| NATURAL GAS | 1.2 | 3.8 |
| PROPANE | 2.9 | 11.0 |

High Altitude Adjustment

Installations located at altitudes from 2000 - 4500 ft. (610 m -1370 m) **DO NOT** require adjustment for altitude. **DO NOT DERATE THIS APPLIANCE FOR ALTITUDE.**

Flame Appearance / Air Shutter Adjustment

The GF 300 DV gas stove is shipped from the factory equipped to burn Natural gas. If the stove has been converted for use with propane, the Air Shutter may require adjustment to achieve the desired flame appearance. Other installation related variables can also affect the flame picture. The Air Shutter may be opened or closed to provide the best flame picture for your specific installation.

Too large an air opening - the appliance will generate a flame that is blue and transparent, or an “anemic” flame.

Too small an air setting - the appliance will generate very long yellow flames resulting in soot. Sooting produces black deposits on the logs, on the inside walls of the appliance, and potentially on the exterior termination cap. Sooting is caused by incomplete combustion in the flames and lack of combustion air entering the air shutter opening.

To adjust the air shutter:

1. Reach under the right side of the stove and loosen the wingnut located closest to you. See fig. 30. Slide the wingnut stud forward to open the air shutter and back to provide less air. Make adjustments in small increments.
2. Tighten the wingnut to secure the shutter at the desired setting.
3. Allow the stove to burn for 30 minutes on the HIGH setting, observing the flame continuously. If the flame appears weak, slow, or sooty, repeat the process described above until the flame is as desired.

WARNING: AIR SHUTTER ADJUSTMENTS SHOULD ONLY BE PERFORMED BY A QUALIFIED PROFESSIONAL SERVICE TECHNICIAN.

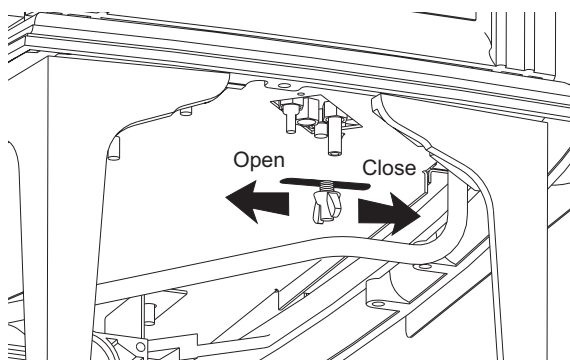

Figure 30. Loosen the wingnut to adjust the air shutter.

Optional Wall Thermostat or Remote Control

Use only a 750 millivolt DC two-wire circuit thermostat with this appliance. The thermostat should be placed in the same room as the heater, typically 5 feet off the floor. Avoid drafty areas or any area that may affect the accuracy of the thermostat.

The thermostat should be connected to the GF 300 DV using a minimum of 16 gauge wire with a maximum length of 25 feet of wire.

Connect the two thermostat wire leads to the two lower terminals on the terminal block located directly above the ignitor button. Do not overtighten the connections. IT IS NOT NECESSARY TO DISCONNECT ANY OTHER WIRES. See Fig. 31.

For thermostatic operation, the On/Off/T-Stat switch on the back of the stove must be in the T-stat position, and the pilot light must be running, as it is the power source for the thermostat.

At the thermostat, the two wires should be connected to the two connection screws on the thermostat base plate per the manufacturer’s instructions.

Remote Control

When using a remote, the remote receiver should be wired to the terminal block the same way the thermostat would be. See the instructions above.

Follow the operating instructions included with the Remote Control unit.

CAUTION:

LABEL ALL WIRES PRIOR TO DISCONNECTION WHEN SERVICING THE CONTROLS. WIRING ERRORS CAN CAUSE IMPROPER OR DANGEROUS OPERATION. ALWAYS VERIFY PROPER OPERATION AFTER SERVICING THE APPLIANCE.

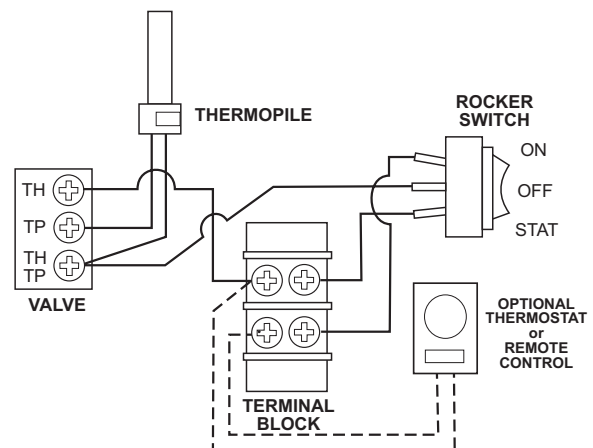

Figure 31. Accessory wiring diagram.

Log Set Installation

Brick Kit Note: Install the optional Antique Brick Kit 155370 before installing the logset. See page 27 and the instructions provided with that kit.

The GF 300 DV logset must be installed before operating the burner. The logset includes four log pieces, packaged inside the firebox, and a quantity of ember stones packaged in the Miscellaneous Parts bag. To install the log set, remove the packaging and place the parts inside the firebox as illustrated in figs 32-36. **Do not handle the log set with your bare hands. Always wear gloves to prevent skin irritation from the ceramic fibers.**

The ember stones realistically simulate glowing coals when the burner is operating. These should be spread evenly over the burner plate and around the logs. **DO NOT OBSTRUCT THE PILOT ASSEMBLY OPENING. Do not pile up the embers in front of the burner skirt edges.** See fig. 36.

NOTE: You do not need to use all of the ember stones. With experimentation, you will find the arrangement and quantity of embers that works best with your stove. Depending upon the characteristics of your installation, it is possible that too many ember stones can promote sooting on the logs. Adjust the quantity of ember stones as appropriate to maintain the best overall flame picture and burner performance.

THE CERAMIC FIBER LOGS AND GLOWING EMBERS CAN IRRITATE YOUR SKIN. GENTLY WASH YOUR HANDS WITH WARM SOAPY WATER AFTER HANDLING THE LOGS.

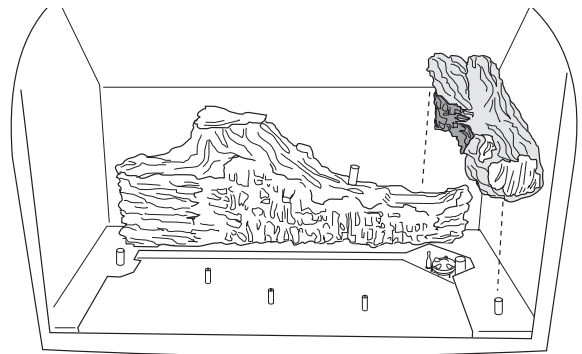

Figure 33. Install Right Log

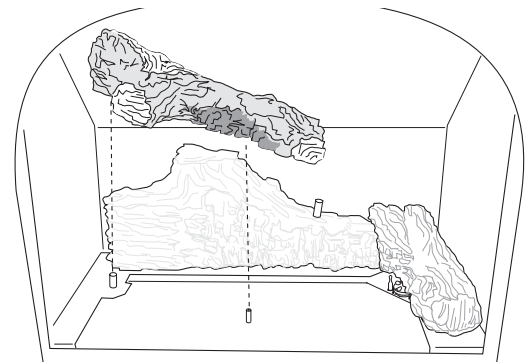

Figure 34. Install Left Log

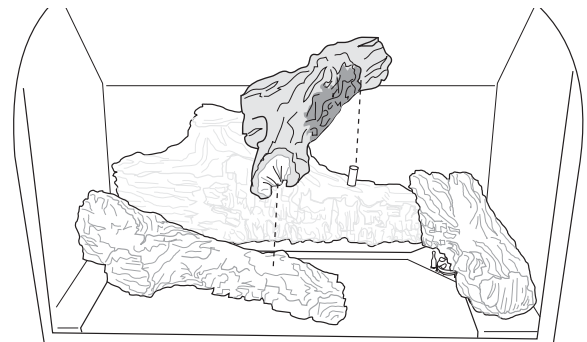

Figure 35. Install Middle Log

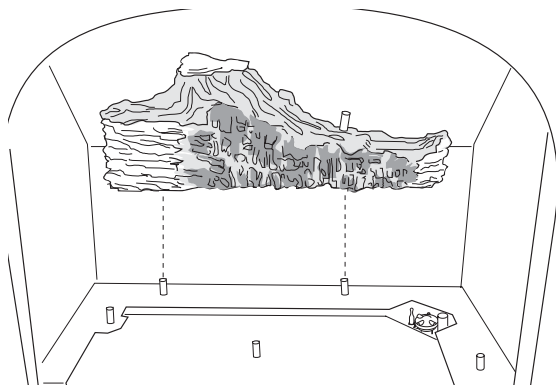

Figure 32. Engage the holes in the underside of the Rear Log with the two pegs in the burner skirt.

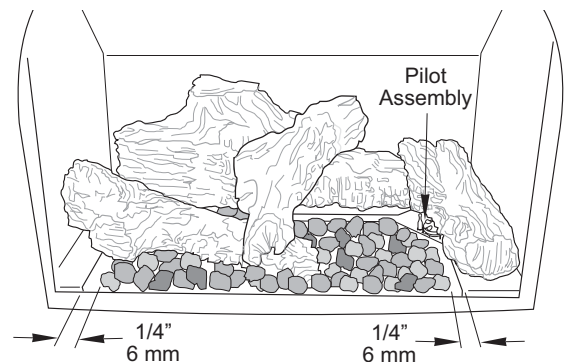

Figure 36. Position embers loosely and maintain 1/4" clearance from the burner skirt edges.

System Check

1. PURGING THE GAS LINE: When lighting the appliance for the first time, it will take a few moments to clear the gas line of air. Once this purge is complete, the appliance will operate as described in the lighting instructions. See the inside back cover of this manual or the stove Rating Plate attached the bottom of the stove. Subsequent burner starts will not require purging the gas line unless the supply line is shut off.

2. PILOT FLAME: You can monitor the pilot flame through the view port located at the rear of the Right Log. See fig. 37. The pilot flame should be steady - not lifting or floating. The flame should be blue in color around the pilot hood, with traces of yellow toward the outer edges.

The pilot flame should engulf the top 3/8" of the thermopile (to generate millivolt current) and the top 1/8" of the thermocouple. The pilot flame should project out of the pilot hood 1" at all three ports. See fig. 37.

3. BURNER ADJUSTMENT: This stove is equipped with a variable gas control valve that allows easy adjustment of the flame height appearance and heat output. To adjust the flame between the HI and LOW setting, rotate the HI/LOW knob, located in the center of the valve face. **Flame height will adjust approximately 1" to 2" between the LOW and HIGH settings. See fig. 38.**

NO SMOKE OR SOOT SHOULD BE PRESENT. CHECK LOG PLACEMENT IF ANY SOOT OR SMOKE IS PRESENT. IF SOOT OR SMOKE PERSISTS, THE AIR SHUTTER MAY NEED TO BE ADJUSTED.

See Air Shutter/Flame Appearance section of this manual for proper air shutter settings and adjustments. Note: the more offsets there are in the vent system, the greater the need for an air shutter adjustment. See page 20.

WARNING:
AIR SHUTTER ADJUSTMENTS SHOULD ONLY BE PERFORMED BY A QUALIFIED PROFESSIONAL SERVICE TECHNICIAN.

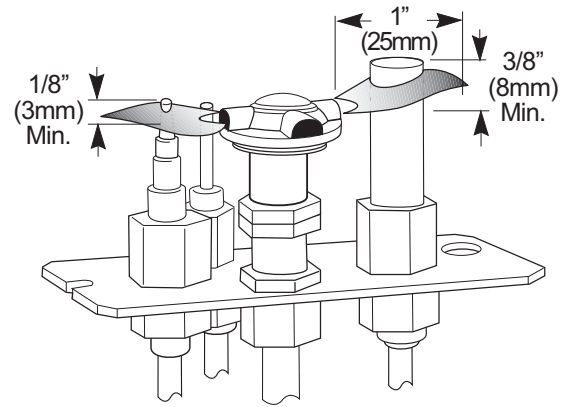

Figure 37. Proper pilot flame appearance.

CAUTION:

DO NOT ATTEMPT TO ALTER THE FLAME APPEARANCE BY POSITIONING THE GAS VALVE CONTROL IN ANY OTHER POSITION OTHER THAN THE FULL "ON" POSITION.

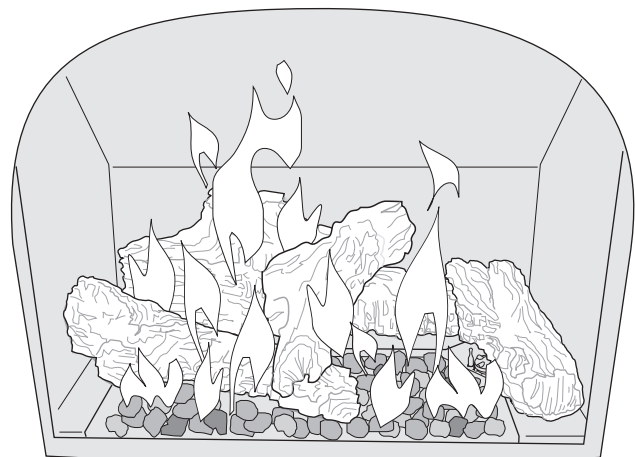

Figure 38. Flame appearance on the "high" setting after approximately 15 to 20 minutes burning.

Operation

Familiarize yourself with the controls of the GF 300 DV. Make sure that anyone else using the appliance is also familiar with the controls and operation procedures. Always follow the Lighting Instructions on the inside back cover of this manual and also located on the Rating Plate attached to the burner assembly.

1. Once the pilot is lit, burner operation is controlled by the rocker switch located at the left corner of the rear shroud. See fig. 39.

ON / OFF - use for manual control of the burner.

T-STAT - use for optional thermostatic or remote control operation. The burner will be controlled by those accessories.

2. During the first few fires, you may notice odor and/or smoke from the stove. This is normal and results from burn-off of manufacturing residue and curing of materials. You may find it helpful to provide additional ventilation and fresh air to alleviate this condition.
3. Condensation may occur on the glass upon each lighting of the appliance. This “fog” will disappear as the appliance heats up.
4. Keep the controls and the area under the appliance free of debris, vacuum this area frequently. Always keep the appliance area clear and free from combustible materials, gasoline and other flammable liquids.

If a vacuum is used during any service on the stove, ALWAYS be sure the stove is cold and there are NO hot embers.

5. Remember, this appliance has a continuous burning pilot flame. Exercise caution when using products having combustible vapors. Always shut-off gas supply while servicing the stove.
6. **CAUTION: DO NOT OPERATE THIS APPLIANCE WITH THE GLASS REMOVED CRACKED OR BROKEN.** Replacement of the glass should be done by a licensed or qualified service person. Use only replacement glass provided by your authorized Jøtul dealer. Never use any substitute materials.

WARNING: OBSERVE CAUTION WITH THE GLASS. THE GLASS PANEL MAY SHATTER UNEXPECTEDLY IF STRUCK WITH AN OBJECT. ALWAYS HANDLE THE GLASS PANEL WITH CARE. WHEN SERVICING THE STOVE ALWAYS PULL THE GLASS ASSEMBLY STRAIGHT UP FOR REMOVAL.

7. Clean the glass only when necessary. Wipe surface with a clean, damp soft cloth. Follow with a dry, soft towel as desired. Take care not to scratch the glass surface.

WARNING: DO NOT USE ABRASIVE CLEANERS ON THE GLASS. NEVER CLEAN THE GLASS WHEN IT IS HOT.

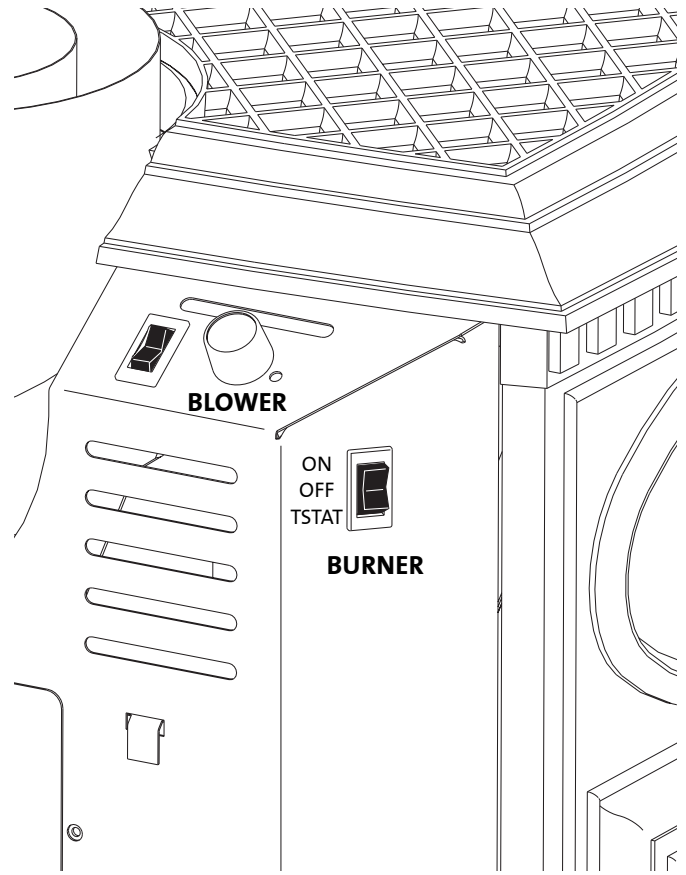

Figure 39. Burner Switch and Optional Blower Controls

Maintenance

Your Jøtul GF 300 DV Allagash and its venting system should be inspected before use and at least annually by a qualified service technician.

Use the form on page 30 to keep a maintenance history of your stove.

IMPORTANT:

ALWAYS TURN OFF THE GAS SUPPLY TO THE FIREPLACE AND UNPLUG THE FORCED AIR BLOWER BEFORE ANY SERVICE WORK IS PERFORMED ON THE FIREPLACE.

Annual Cleaning

Vent System

The entire vent system, including the chimney, should be inspected and cleaned every year. If the intake and exhaust venting is disassembled for any reason, it should be reassembled and sealed according to the manufacturer's instructions provided at the initial installation.

Burner and Logset

Periodically inspect the Firebox, Valve Compartment, Convection Airways and optional Blower to BE CERTAIN THAT THE FLOW OF COMBUSTION AND VENTILATION AIR IS UNOBSTRUCTED.

The firebox should be vacuumed annually to remove any surface build up. Use a soft brush attachment and handle the logs carefully as they are fragile. Be sure to vacuum or wipe off the pilot assembly and burner surfaces.

Glass Care

Clean the glass only when necessary. Wipe the surface with a clean, dampened, soft cloth. Follow with a dry, soft towel. Take care not to scratch the glass surface.

WARNING:

DO NOT USE ABRASIVE CLEANERS ON THE GLASS. NEVER CLEAN THE GLASS WHEN IT IS HOT.

Gasket Inspection

It is important that the glass gasket be inspected at least annually. Examine the ribbon gasket for signs of deterioration and make sure the gasket has a positive seal. Replace the gasket if necessary. Refer to the replacement parts list on page 29.

FOR REPLACEMENT, USE ONLY JØTUL CERAMIC GLASS PANEL 220576. DO NOT USE ANY OTHER TYPE OF GLASS WITH THIS APPLIANCE.

Glass Panel or Gasket Removal

1. Lift the Top Plate off of the stove.
2. Release the two Glass Frame Latches. Pull each latch handle forward to disengage the latch from the notches in the glass frame.
3. Lift the glass frame all the way up and out of the top of the stove. Lay this assembly on a flat surface, protecting the frame from scratches using a blanket or towel.
3. The glass panel is held in place by four compression clips. Use a screwdriver or small pliers to pry these up off the edge of the glass retaining walls. See fig. 40.
4. Remove the old gasket material. See fig. 41.

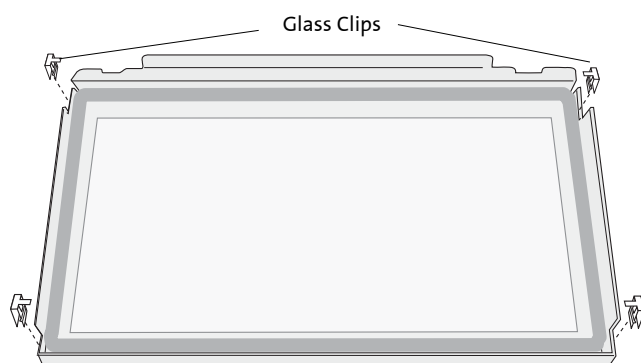

Figure 40. Use small pliers to pry the clips off of the glass panel frame.

Glass Panel or Gasket Replacement

1. Wrap the new gasketing material evenly around the edge of the glass, peeling back the protective strip to expose the adhesive as you go. Press the adhesive side down onto the glass surface. Do not stretch the gasket.
2. Place the gasketed glass within the frame and press each of the retainer clips back into place on the retainer walls.

Figure 41 . Wrap the gasket around the glass panel.

Optional Blower # 155371

Read these instructions before beginning the installation.

1. **Unpack and check the contents** of the blower kit. The kit includes two Air Deflectors and two #7 x 1/2" screws that will not be used with the GF 300 DV Allagash stove. Contact your dealer if any damage is evident or parts are missing. See fig. 42.
2. **Install the Snapstat** by sliding it all the way into the slot in the bottom of the Snapstat Bracket as shown in fig. 43.
3. **Attach the Snapstat Bracket** to the studs located in the middle of the firebox floor using the two M6 hex nuts and a 10 mm wrench. See fig. 43.
4. **Attach the Blower Bracket** to the stove using the two M6 flange head hex bolts as shown in fig. 43.
5. **Install the Blower** with the duct openings oriented up and to the rear. See fig. 44. Feed the snapstat wire harness through the bracket opening and secure the blower to the bracket with the wingscrew. Route the controls wire harness over to the female quickconnector already installed in the stove.
6. **Attach either Snapstat wire connector** to either Snapstat terminal. See fig. 44.
7. **Connect the male Control Switch connector** to the female control switch wire harness already installed in the stove. See fig. 44.
8. Connect power cord to outlet.

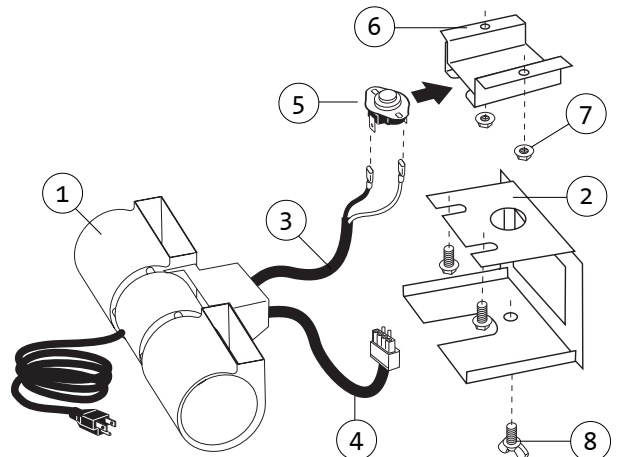

Contents

1. Blower
2. Mounting Bracket
3. Snapstat Wire Harness
4. Control Switch Wire Harness
5. Snapstat
6. Snapstat Bracket
7. M6 x 1 x 20 Flange Nuts (2)
8. M6 x 12 Wingscrew

Tools Required

- 10 mm wrench

Figure 42 . Blower Kit Components

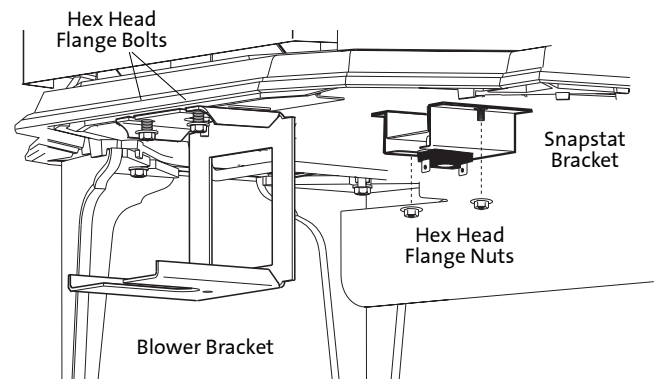

Figure 43 . Attach Snapstat and Blower Brackets.

■ **THIS BLOWER MUST BE ELECTRICALLY GROUNDED IN ACCORDANCE WITH LOCAL CODES OR, IN THE ABSENCE OF LOCAL CODES, WITH THE CURRENT ANSI/ NFPA 70, NATIONAL ELECTRICAL CODE OR CSA C22.1-CANADIAN ELECTRICAL CODE.**

■ **THIS UNIT IS SUPPLIED WITH A THREE-PRONG (GROUNDING) PLUG FOR PROTECTION AGAINST SHOCK HAZARD AND SHOULD BE PLUGGED DIRECTLY INTO A PROPERLY GROUNDED THREE-PRONG RECEPTACLE. DO NOT CUT OR REMOVE THE GROUNDING PRONG FROM THE PLUG.**

■ **ALWAYS DISCONNECT THE POWER SUPPLY WHEN PERFORMING ANY SERVICE ON THE FIREPLACE INSERT.**

Figure 44. Attach Blower to the Mounting Bracket with the wingscrew and connect wires to Snapstat and female control quick connect.

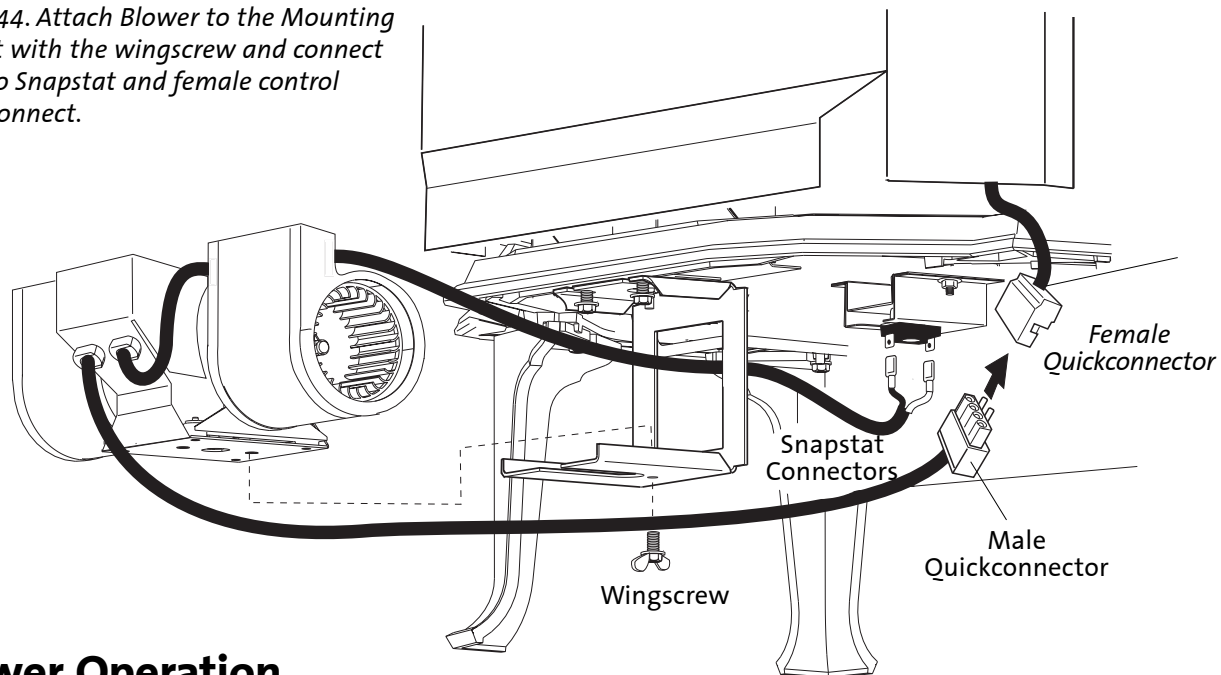

Blower Operation

The optional variable-speed blower will enhance heat circulation around the firebox and out into the room. The blower is controlled by a heat activated switch (snapstat) that will ONLY function when the control switch is in AUTO setting. After the fire has been burning for a time, the snapstat will react to the heat and activate the blower. Fan speed may be manually adjusted with the rheostat knob. If the burner turns off, the blower will be shut off automatically when the stove cools down.

If automatic blower circulation is not desired, place the blower control switch in the MANUAL position.

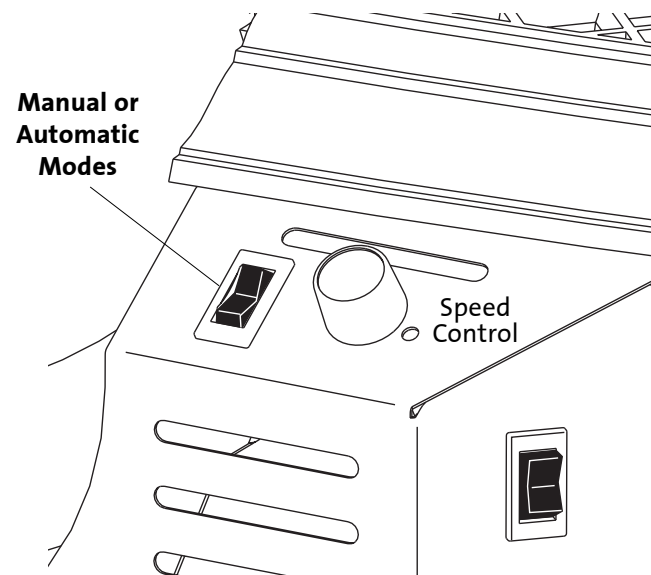

Figure 45. Blower Controls

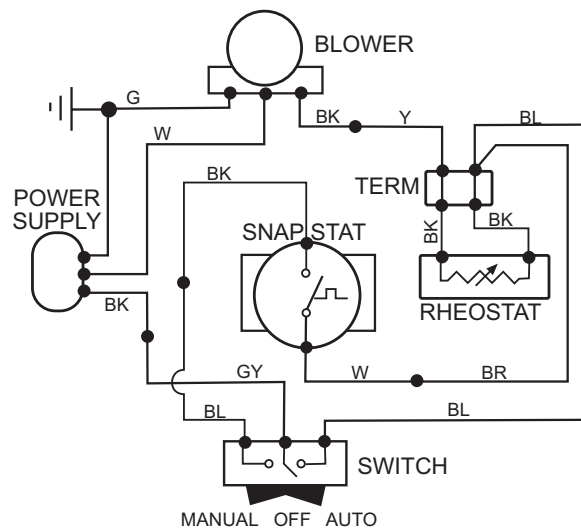

Figure 46 . Blower Wiring Diagram

Optional Antique Brick Kit # 155370

CAUTION!
THE BRICK PANELS AND LOG PARTS ARE EXTREMELY FRAGILE. HANDLE WITH CARE.

Read these instructions before beginning the installation.

1. **Remove the Top Plate.** Simply lift it up off of the stove body. It is not fastened.
2. **Remove the Glass Frame.** Disengage the two compression latches located at the top of the firebox and lift the glass frame up and off of the stove. See fig. 48.
3. **If installed, remove the Logset.** These parts are not fastened. Simply lift them out of the firebox. You do not have to remove the embers.
4. **Install the Lower Rear Panel.** Position it up against the back wall, resting on the burner skirt. Fig. 49.
5. **Install a Side Panel.** Tilt the panel, bottom edge first, into position against the side wall. The panel will stand on its own against the wall, fitting snugly between the rear panel and the front wall of the firebox. Fig. 50.
6. **Install the Upper Rear Panel.** Simply rest it on the other two panels. Fig. 51.
7. **Install the other Side Panel.**
8. **Reinstall the Logset.** Refer to the Owner's Manual if necessary. **BE CERTAIN THAT NO EMBER STONES ARE BLOCKING THE PILOT ASSEMBLY OPENING.** Refer to fig. 36.
9. **Replace the Glass Frame.** Slide the frame down the slot in the front of the firebox. Be sure to push the frame into the slot in the bottom to ensure it is fully seated. The gasket at the top of the frame should be flush with the top of the firebox.
Pull the compression latches out to engage with the top lip of the glass frame.
10. **Replace the Top Plate.**

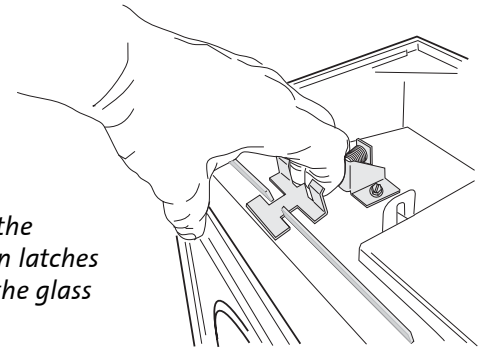

Figure 48.
Disengage the compression latches to remove the glass frame.

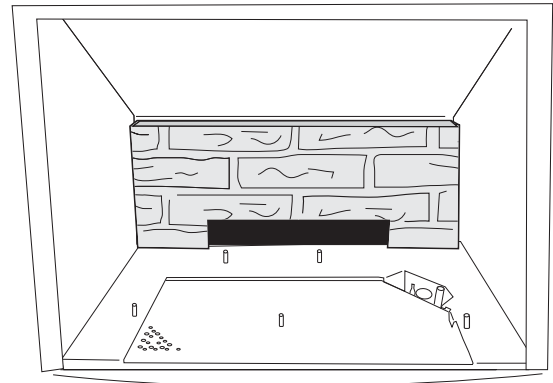

Figure 49. Install Lower Rear Panel

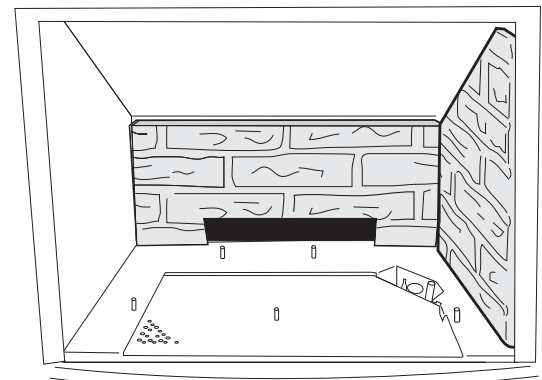

Figure 50. Install Side Panel

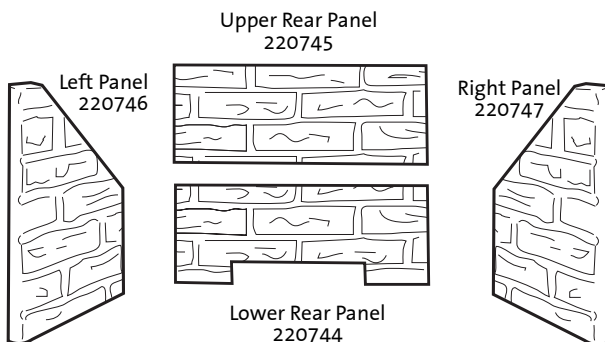

Figure 47. Brick Kit Contents

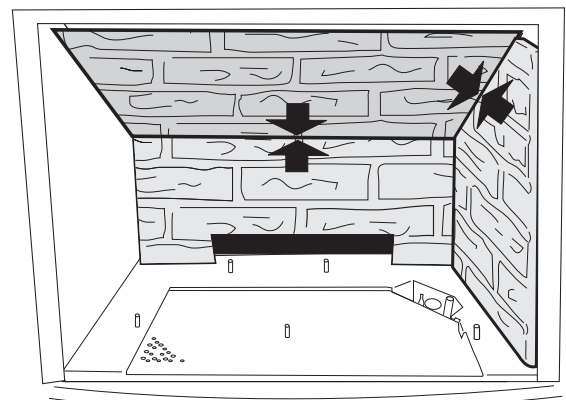

Figure 51. Install Upper Rear Panel

GF 300 DV Illustrated Parts Breakdown

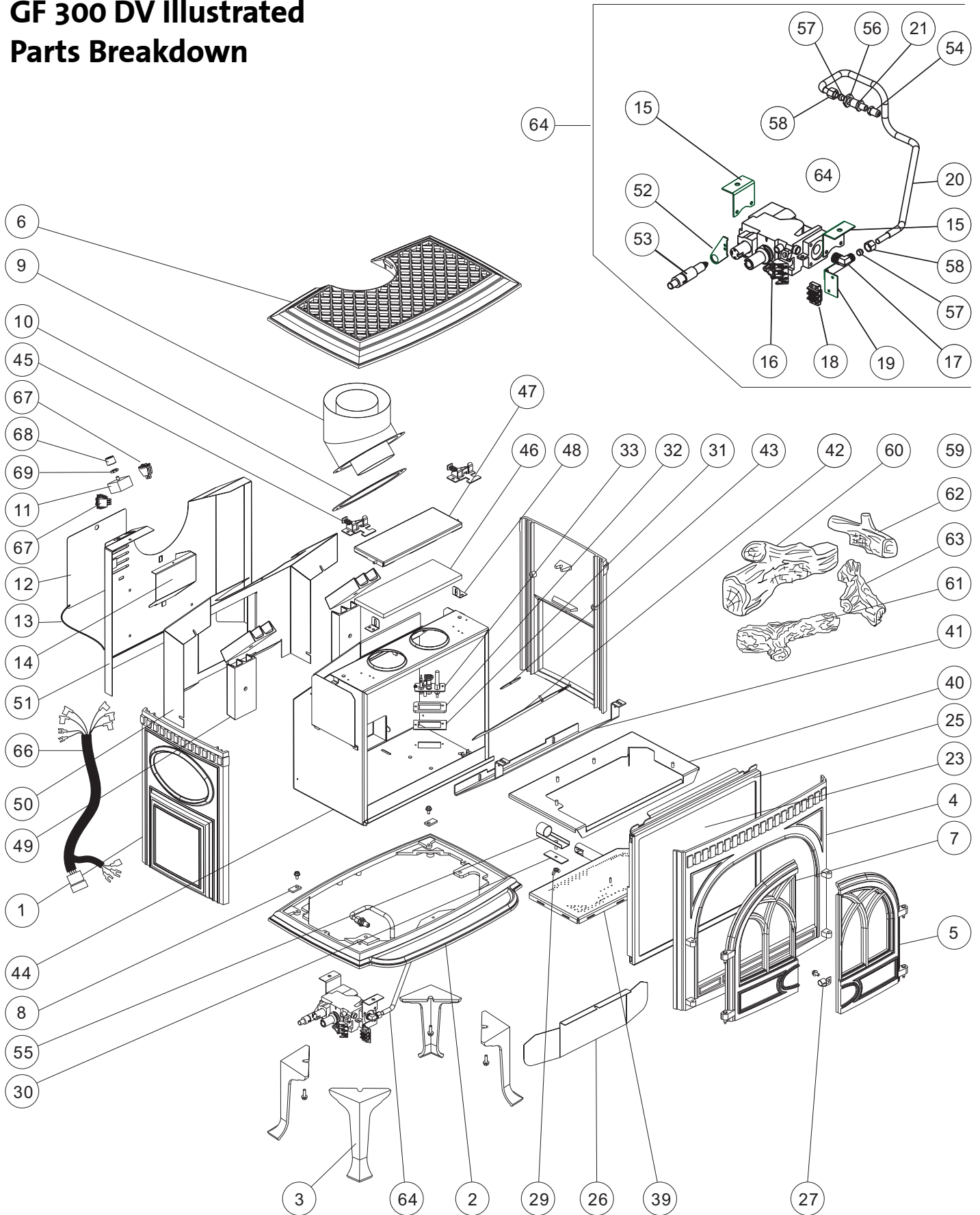

Figure 52. Illustrated Parts Breakdown - GF 300 DV Allagash

GF 300 DV Allagash Parts List

| Cast Iron Parts | Matte Black | Blue Black | Ivory | Forest Green | Jøtul Iron |
|-----------------|-------------|------------|----------|--------------|------------|
| 1. Side Plate | 10203292 | 102033 | 10203229 | 10203232 | 10203285 |
| 2. Base Plate | 10390092 | 10390027 | 10390029 | 10390032 | 10390085 |
| 3. Legs, (4) | 10192592 | 101966 | 102251 | 10192532 | 10192585 |
| 4. Front Panel | 10390192 | 10390127 | 10390129 | 10390132 | 10390185 |
| 5. Right Door | 10390492 | 10390427 | 10390429 | 10390432 | 10390485 |
| 6. Top Plate | 10390292 | 10390227 | 10390229 | 10390232 | 10390285 |
| 7. Left Door | 10390392 | 10390327 | 10390329 | 10390332 | 10390385 |

| | | | | | |
|---|----------|--|--|--|--|
| 8. Side Clip | 128401 | | | | |
| 9. Simpson DuraVent Collar | 129126 | | | | |
| 10. Collar Gasket | 129118 | | | | |
| 11. Rheostat | 220700 | | | | |
| 12. Rating Plate | 220612 | | | | |
| 13. Lanyard | 129159 | | | | |
| 14. Controls Shroud | 220594 | | | | |
| 15. Valve Bracket | 220721 | | | | |
| 16. Valve - NG | 220520 | | | | |
| 17. Elbow, 3/8" Brass | 129129 | | | | |
| 18. Terminal Block | 129154 | | | | |
| 19. Bracket, Terminal Block | 220614 | | | | |
| 20. Gas Line, 5/16" x 22" Flex | 220740 | | | | |
| 21. Orifice Holder, Straight | 129643 | | | | |
| 22. * Glass/Gasket Replacement Kit | 155599 | | | | |
| 23. Glass Panel, Ceramic | 220576 | | | | |
| 24. •Glass Gasket, 7/16" Tadpole, 6 ft. | 129124 | | | | |
| 25. Glass Frame, Matte Black | 22032792 | | | | |
| 26. Glass Clips, (4) | 220042 | | | | |
| 27. Door Latch | 220604 | | | | |
| 28. Valance, Matte Black | 22072092 | | | | |
| 29. Wingnut | 117975 | | | | |
| 30. Air Shutter Gasket | 220734 | | | | |
| 31. Pilot Assembly Gasket | 129670 | | | | |
| 32. Pilot Assembly Spacer | 220546 | | | | |
| 33. Pilot Assembly, w/NG orifice | 129471 | | | | |
| 34. Pilot Orifice NG #51 | 129472 | | | | |
| Pilot Orifice LP #30 | 129473 | | | | |
| 35. Pilot Line w/ Fitting | 129446 | | | | |
| 36. Thermocouple | 129766 | | | | |
| 37. Electrode | 129765 | | | | |
| 38. Thermopile | 3094527 | | | | |
| 39. Burner Assembly | 155368 | | | | |
| 40. Burner Skirt | 220588 | | | | |
| 41. Exhaust Baffle | 220541 | | | | |
| 42. Exhaust Restrictor | 220543 | | | | |
| 43. Exhaust Restrictor Gasket | 220734 | | | | |
| 44. Firebox Assembly | 155583 | | | | |
| 45. Latch Assembly | 220091 | | | | |
| 46. Relief Door Gasket | 220735 | | | | |
| 47. Relief Door, Matte Black | 22058992 | | | | |
| 48. Relief Door Guide | 129499 | | | | |
| 49. Heat Fins, (4) | 155653 | | | | |
| 50. Inner Shroud, | 220593 | | | | |
| 51. Rear Shroud, Complete | 220718 | | | | |
| 52. Ignitor Bracket | 3902576 | | | | |
| 53. Ignitor | 3902573 | | | | |
| 54. Burner Orifice, NG #39 | 129367 | | | | |
| Burner Orifice, LP #53 | 220731 | | | | |
| 55. Primary Air Shutter II | 220791 | | | | |
| 56. Jam Nut - Orifice Holder | 129152 | | | | |
| 57. Ferrule, 5/16" (2) | 129463 | | | | |
| 58. Nut, 5/16" (2) | 129464 | | | | |
| 59. Log Set, Complete | 155584 | | | | |
| 60. Rear Log | 220727 | | | | |
| 61. Left Log | 220728 | | | | |
| 62. Right Log | 220729 | | | | |
| 63. Middle Log | 220730 | | | | |
| 64. Gas Valve Assembly | | | | | |
| 65. * Embers, 4 Oz. | 220702 | | | | |
| 66. Wire Harness Assembly | 155397 | | | | |
| 67. Rocker Switch, 2 | 220703 | | | | |
| 68. Rheostat Knob | 220709 | | | | |
| 69. Retaining Collar | 220717 | | | | |
| 70. * Terminal Block, Ceramic | 118006 | | | | |
| 71. * Wire, Terminal Block Jumper - 3" Blue | 155557 | | | | |
| 72. * Fender Washer | 118023 | | | | |
| 73. * Leg Bolt, | 117117 | | | | |
| 74. * Misc. Kit | 155575 | | | | |
| 75. * Door Hinge Pin | 122075 | | | | |

*not illustrated

Accessories

| | |
|------------------------------------|--------|
| Antique Brick Panel Kit | 155370 |
| Variable Speed Blower | 155371 |
| Fuel Conversion Kit to Propane | 155372 |
| Fuel Conversion Kit to Natural Gas | 155373 |
| Spark Screen | 129174 |
| Wall Thermostat | 750003 |
| Remote Control | 750002 |
| Floor Bracket Kit | 154388 |
| Torx T20 screwdriver | 110002 |
| 4 mm Allen wrench | 129646 |
| Snapstat | 220617 |

**ALWAYS USE REPLACEMENTS PARTS
PROVIDED BY AN AUTHORIZED JØTUL
DEALER ONLY.**

Record the following information to help your dealer determine what you will need for parts and service.

MODEL NAME: GF 300 DV

SERIAL NUMBER: _____

DATE OF PURCHASE: _____

PURCHASED FROM: _____

NAME OF INSTALLER: _____

TYPE OF FUEL: _____

WAS STOVE CONVERTED? _____

NOTES:

**RETAIN THIS MANUAL FOR REFERENCE
AND MAKE IT AVAILABLE TO ANYONE
USING OR SERVICING THE STOVE.**

LIGHTING INSTRUCTIONS

FOR YOUR SAFETY, READ BEFORE LIGHTING.

WARNING:
IF YOU DO NOT FOLLOW THESE INSTRUCTIONS EXACTLY, A FIRE OR EXPLOSION MAY RESULT CAUSING PROPERTY DAMAGE, PERSONAL INJURY, OR LOSS OF LIFE.

- A.** This appliance has a pilot which must be lit by hand. When lighting the pilot, follow these instructions exactly.
- B. BEFORE LIGHTING**, smell all around the appliance area for gas. Be sure to smell next to the floor because some gas is heavier than air and will settle to the floor.
- WHAT TO DO IF YOU SMELL GAS:**
- Extinguish any open flame.
 - Open windows.
 - Do not light any appliance.
 - Do not touch any electrical switches.
 - Do not use any phone in your building.
 - Immediately call your gas supplier from a neighbor's phone.
- If your gas supplier cannot be reached, call the fire department.
- C.** Use only your hand to push in or turn the gas control knob. Never use tools. If the knob will not push in or turn by hand, do not try to repair it. Call a qualified technician. Force or attempted repair may result in a fire or explosion.
- D.** Do not use this appliance if any part has been under water. Immediately call a qualified service technician to inspect the appliance and to replace any part of the control system and any gas control which has been under water.

LIGHTING INSTRUCTIONS

1. STOP! Read the safety information above.
2. Access the lower controls.
3. Turn the stove ON/OFF switch to "OFF", or set the thermostat to lowest setting (if used).
4. Confirm that the gas supply line shut-off valve is open.

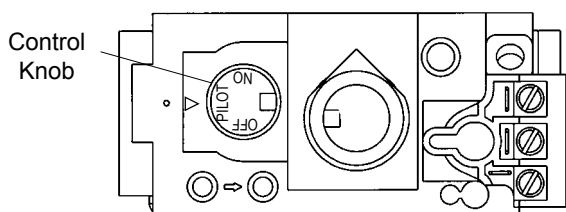

Control Valve

5. Push in gas control knob slightly and turn clockwise ➡ to "OFF".
 NOTE: Knob cannot be turned from "PILOT" to "OFF" unless the knob is pushed in slightly. Do not force.
6. Wait five (5) minutes to clear out any gas. If you then smell gas, STOP! Follow "B" in the safety information above on this page. If you do not smell gas, go to the next step.

7. Push in gas control knob slightly and turn counterclockwise ↶ to "PILOT".
8. Push in control knob all the way and hold in. Immediately light the pilot by triggering the spark ignitor (push the red button repeatedly) until pilot lights. Continue to hold the control knob in for about one minute after the pilot lights. Release knob and it should spring back. The pilot should remain lit. If it goes out, repeat Steps 5 through 8.

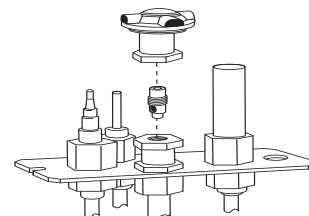

Pilot Assembly

- If knob does not return when released, stop and immediately call your service technician or gas supplier.
 - If pilot will not stay lit after several tries, turn the control knob to OFF and call your service technician or gas supplier.
9. Turn gas control knob counterclockwise ↶ to "ON".
 10. Turn the stove ON/OFF switch to "ON", or set thermostat (if used) to desired temperature.

TO TURN OFF GAS TO THE APPLIANCE:

1. Turn ON/OFF switch to "OFF". The pilot will remain lit for normal service.
2. For complete shutdown, turn ON/OFF switch to "OFF".
3. Access the lower controls.
4. Depress gas control knob slightly and turn clockwise ➡ to "OFF". Do not force.



This appliance must be installed in conformance with local and national building regulations. It is important that these instructions be carefully read and understood before beginning the installation. Jøtul pursues a policy of continual product development. Consequently, products may differ in specification, color or type of accessories from those illustrated or described in various publications.

Jøtul vise sans cesse a ameliorer ses produits. C'est pourquoi, il se reserve le droit de modifier les specifications, couleurs et equipement sans avis prelable.

Jøtul ASA

P.O. Box 1411

N-1602 Fredrikstad, Norway

Jøtul North America

400 Riverside Street
Portland, ME 04104

7.04 137775-C