





# Convenience & Comfort.

Enjoy the warmth of Hearthstone.

## Zone Heating

As an on-demand heat source, a Hearthstone gas generates the heat you want, when and where you want it. Ultra efficient, our gas stoves exceed combustion efficiency standards and encourage a zone heating scheme. You're cozy when and where you need to be, with minimal effort. A variable flame height adjuster allows you to easily control the temperature and the ambiance of your room.

## Our Promise

For more than 35 years, dedicated Vermont craftsmen have been committed to building quality products. It's our commitment - our guarantee - that each Hearthstone is built with integrity in the Hearthstone tradition. Through time-tested craftsmanship, high-quality materials, and the latest heating technology, we ensure your Hearthstone will serve you faithfully for years.

That's our promise.

### TRADITIONAL



Bristol  
4



Sterling  
6



Champlain  
8



Tucson  
10



Stowe  
12



Tribute  
14

### CONTEMPORARY



Bari  
16



Modena  
18



Luno  
20

### INSERTS



Quinlan-44  
22



Larkin-44  
22



Coburn-44  
22



Quinlan-38  
24



Larkin-38  
24



Coburn-38  
24



Killington  
28



Maidstone  
30



Willoughby  
30



# BRISTOL DX

## GAS STOVE



### FINISH OPTIONS:



Matte Black



Brown Majolica Enamel



Basil Majolica Enamel

Control panel.

Smart remote.



Bristol featured in Basil Majolica Enamel.

## BRISTOL DX 8762 FEATURES AND BENEFITS

- **3-sided viewing** – enjoy the flames from any angle
- **Ceramic logs and burner** – realistic flame presentation
- **2-stage burner** – turn the front burner on/off and modulate the flame height
- **High turn down** – adjust the flame to meet your desired comfort
- **Built-in convection blower** – circulates warm air
- **Smart remote** – features remote thermostat, smart thermostat, 10-level flame control, 5-speed fan control, pilot control and child lock-out
- **Intermittent pilot** – conserves gas when unit is off
- **Cast iron heat exchanger** – maximizes heat output and improves efficiency
- **Direct-Vent technology** – combustion air is drawn from outside to reduce drafts, maintain indoor air quality, and boost efficiency

## SPECIFICATIONS

Heater Rated Appliance .....	AFUE Certified
Heats up to .....	1,800 sq ft
Burn Rate Range NG .....	16,000 - 36,000 BTUs/hr
Burn Rate Range LP .....	10,000 - 33,000 BTUs/hr
Venting .....	Top, 4" x 6-5/8" DV
Ignition System .....	ProFlame II Intermittent pilot
Burner .....	2-Stage Ceramic Burner
On-Off-Remote Switch .....	Included
Smart Remote Control .....	Included
Convection Blower .....	Included
Screen .....	Included
LP Conversion Kit .....	Optional
Mobile Home Certified .....	Yes
Actual Weight .....	180 lbs

## CLEARANCES TO COMBUSTIBLE MATERIALS

Side .....	16"
Rear .....	2"
Corner .....	11"

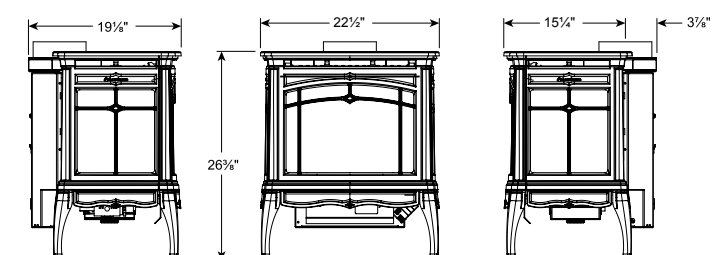

## EFFICIENT PERFORMANCE WITH PANORAMIC THREE-SIDED VIEWING

The Bristol DX offers innovation and efficiency. Panoramic 3-sided viewing allows you to enjoy the flames from any angle. Control the room temperature, adjust the flame height, enable the blower ... with the Bristol DX, you can control your stove and comfort level, with simply the touch of a button.



# STERLING HT

## GAS STOVE



### FINISH OPTIONS:



Matte Black



Brown Majolica Enamel

### STONE OPTIONS:



Titanium Pearl



Autumn Brown Granite



Aztec Green Marble

## STERLING HT 8532 FEATURES AND BENEFITS

- **Stone selection** – customize your stove for any decor
- **Ceramic logs and burner** – realistic flame presentation
- **2-stage burner** – turn the rear burner on/off and modulate the flame height
- **High turn down** – adjust the flame to meet your desired comfort
- **Wall thermostat** – easy operation
- **Continuous pilot** – maintains a warm firebox for quick starts
- **Cast iron heat exchanger** – maximizes heat output and improves efficiency
- **Direct-Vent technology** – combustion air is drawn from outside to reduce drafts, maintain indoor air quality, and boost efficiency

## SPECIFICATIONS

Heater Rated Appliance .....	AFUE Certified
Heats up to .....	Up to 1,800 sq ft
Burn Rate Range NG/LP .....	12,000 - 38,000 BTUs/hr
Venting, Top .....	4" x 6-5/8" DV *
Venting, Rear .....	4" x 6-5/8" or 5 x 8" DV *
Ignition System .....	Continuous pilot
Burner .....	2-Stage Ceramic Burner
On-Off-Thermostat Switch .....	Included
Wall Thermostat .....	Included
Programmable Thermostat .....	Optional
Thermostatic Remote Control .....	Optional
Convection Blower .....	Optional
Screen .....	Included
LP Conversion Kit .....	Included
Mobile Home Certified .....	Yes
Actual Weight .....	230 lbs

\* starter collar required, order separately



Sterling featured in Brown Majolica Enamel with Titanium Pearl.



Sterling featured in Matte Black with Aztec Green Marble.

## CLEARANCES TO COMBUSTIBLE MATERIALS

Side .....	4"
Rear .....	2"
Corner .....	2"

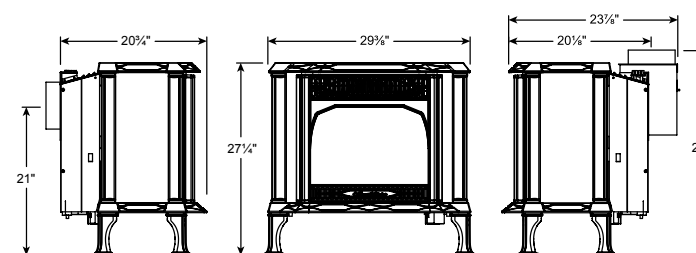

## A CENTERPIECE FOR CREATING GENEROUS WARMTH IN YOUR HOME

A powerful heater, the Sterling will heat your midsize home with ease. The Sterling combines the convenience and efficiency of gas, and the radiant warmth of stone and cast iron. A variable flame lets you control the fire's intensity. Plus, the Sterling offers convenient venting configurations to make installation possible in any space.



# CHAMPLAIN

## GAS STOVE



### FINISH OPTIONS:



Matte Black



Brown Majolica Enamel

Champlain featured in Matte Black.



## CHAMPLAIN 8301 FEATURES AND BENEFITS

- **Ceramic logs** – realistic flame presentation
- **High turn down** – adjust the flame to meet your desired comfort
- **Wall thermostat** – easy operation
- **Continuous pilot** – maintains a warm firebox for quick starts
- **Cast iron heat exchanger** – maximizes heat output and improves efficiency
- **Direct-Vent technology** – combustion air is drawn from outside to reduce drafts, maintain indoor air quality, and boost efficiency

## SPECIFICATIONS

Heater Rated Appliance.....	AFUE Certified
Heats up to.....	Up to 1,800 sq ft
Burn Rate Range NG.....	21,500 - 35,000 BTUs/hr
Burn Rate Range LP.....	21,500 - 35,000 BTUs/hr
Venting.....	45°, 4" x 6-5/8" DV
Ignition System.....	Continuous pilot
Burner.....	Pan Burner
On-Off-Thermostat Switch.....	Included
Wall Thermostat.....	Included
Programmable Thermostat.....	Optional
Thermostatic Remote Control.....	Optional
Convection Blower.....	Optional
Screen.....	Included
LP Conversion Kit.....	Included
Mobile Home Certified.....	Yes
Actual Weight.....	220 lbs

## CLEARANCES TO COMBUSTIBLE MATERIALS

Side.....	4"
Rear.....	2"
Corner.....	2"

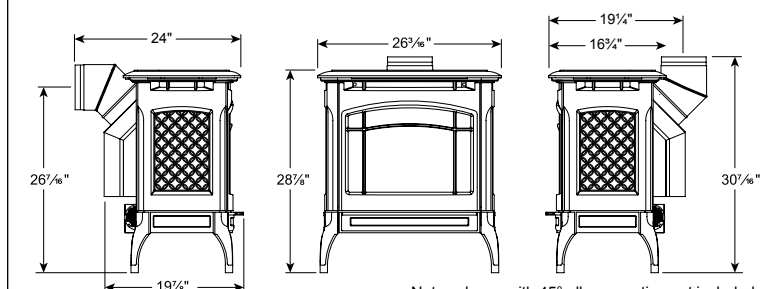

Note: shown with 45° elbow, venting not included.

## A COST-EFFECTIVE ZONE HEATING SOLUTION

The Champlain direct-vent, gas-fired stove is one of our larger cast iron gas stoves. A cast iron heat exchange system boosts efficiency. The included wall thermostat and optional convection blower let you maintain your room temperature at a preset comfort level.



# TUCSON DX

## GAS STOVE



Tucson featured in Brown Majolica Enamel with Autumn Brown Granite.

### PERFECTLY SCALED TO COMPLEMENT MOST LIVING ENVIRONMENTS

The Tucson DX model excels in easy, effortless functionality and gives you a variety of features all programmable from our signature remote. Now you can control your stove from the comfort of your sofa with the touch of a button. As beautiful as it is smart, the Tucson DX model is perfectly scaled to complete most living environments.



Tucson featured in Basil Majolica Enamel with Pine Green stone.

#### FINISH OPTIONS:

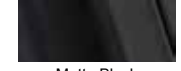

Matte Black



Brown Majolica Enamel



Basil Majolica Enamel

#### STONE OPTIONS:



Polished Soapstone



Autumn Brown Granite



Pine Green



Kodiak Brown

Smart remote.



### TUCSON DX 8702 FEATURES AND BENEFITS

- **HeatWave refractory** – Directs the heat of the flame to the glass, maximizing the radiant heat from the stove.
- **Stone selection** – customize your stove for any decor
- **Ceramic logs and burner** – realistic flame presentation
- **High turn down** – adjust the flame to meet your desired comfort
- **Built-in convection blower** – circulates warm air
- **Smart remote** – features remote thermostat, smart thermostat, 5-level flame control, 5-speed fan control, auxiliary outlet and child lock-out
- **Intermittent pilot** – conserves gas when unit is off
- **Cast iron heat exchanger** – maximizes heat output and improves efficiency
- **Direct-Vent technology** – combustion air is drawn from outside to reduce drafts, maintain indoor air quality, and boost efficiency

### SPECIFICATIONS

Heater Rated Appliance .....	AFUE Certified
Heats up to .....	1,200 sq ft
Burn Rate Range NG .....	18,000 - 26,000 BTUs/hr
Burn Rate Range LP .....	21,600 - 25,000 BTUs/hr
Venting .....	45°, 4" x 6-5/8" DV
Ignition System .....	ProFlame Intermittent pilot
Burner .....	Ceramic Burner
On-Off-Remote Switch .....	Included
Smart Remote Control .....	Included
Convection Blower .....	Included
Screen .....	Included
LP Conversion Kit .....	Optional
Mobile Home Certified .....	Yes
Actual Weight .....	155 lbs

### CLEARANCES TO COMBUSTIBLE MATERIALS

Side .....	6"
Rear .....	2"
Corner .....	4"

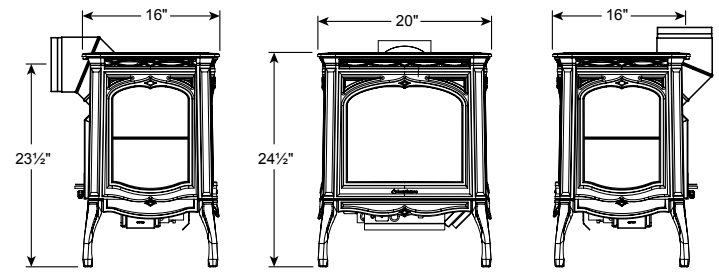

Note: shown with 45° elbow, venting not included.



# STOWE DX

## GAS STOVE



### FINISH OPTIONS:



Matte Black



Brown Majolica Enamel



Basil Majolica Enamel



Oyster Enamel



Smart remote.

Stove featured in Brown Majolica Enamel.



## STOWE DX 8322

### FEATURES AND BENEFITS

- **HeatWave refractory** – Directs the heat of the flame to the glass, maximizing the radiant heat from the stove.
- **Stone selection** – customize your stove to fit your space
- **Ceramic logs and burner** – realistic flame presentation
- **High turn down** – adjust the flame to meet your desired comfort
- **Built-in convection blower** – circulates warm air
- **Smart remote** – features remote thermostat, smart thermostat, 5-level flame control, 5-speed fan control, auxiliary outlet and child lock-out.
- **Intermittent pilot** – conserves gas when unit is off
- **Cast iron heat exchanger** – maximizes heat output and improves efficiency
- **Direct-Vent technology** – combustion air is drawn from outside to reduce drafts, maintain indoor air quality, and boost efficiency

### SPECIFICATIONS

Heater Rated Appliance.....	AFUE Certified
Heats up to.....	1,200 sq ft
Burn Rate Range NG.....	18,000 - 26,000 BTUs/hr
Burn Rate Range LP.....	21,600 - 25,000 BTUs/hr
Venting.....	45°, 4" x 6-5/8" DV
Ignition System.....	ProFlame Intermittent pilot
Burner.....	Ceramic Burner
On-Off-Remote Switch.....	Included
Smart Remote Control.....	Included
Convection Blower.....	Included
Screen.....	Included
LP Conversion Kit.....	Optional
Mobile Home Certified.....	Yes
Actual Weight.....	155 lbs

### CLEARANCES TO COMBUSTIBLE MATERIALS

Side.....	4"
Rear.....	2"
Corner.....	3"

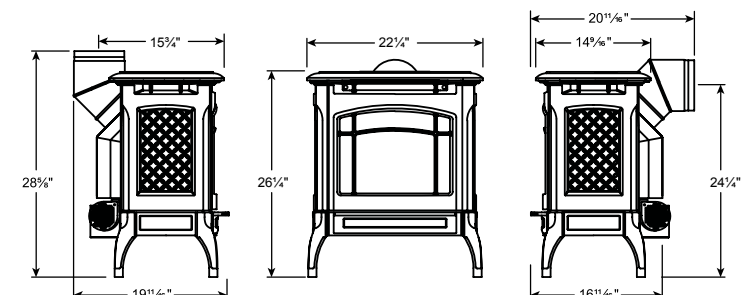

Note: shown with 45° elbow, venting not included.

## EFFICIENT BEAUTY AT ITS BEST

A great model with innovation and efficiency built in! Our Stowe DX gas stove brings you the height of direct-vent technology with the ProFlame electronic ignition system. The HeatWave refractory panel projects heat into the room.



# TRIBUTE DV

## GAS STOVE



### FINISH OPTIONS:



Matte Black



Brown Majolica Enamel

### STONE OPTIONS:



Titanium Pearl



Autumn Brown Granite

Tribute DV featured in Brown Majolica Enamel with Titanium Pearl stone.



## TRIBUTE DV 8050 FEATURES AND BENEFITS

- **Stone selection** – customize your stove for any decor
- **Optional rear stones** – finishes the stove on all sides
- **Ceramic logs and burner** – realistic flame presentation
- **Wall thermostat** – easy operation
- **Continuous pilot** – maintains a warm firebox for quick starts
- **Cast iron heat exchanger** – maximizes heat output and improves efficiency
- **Direct-Vent technology** – combustion air is drawn from outside to reduce drafts, maintain indoor air quality, and boost efficiency

## SPECIFICATIONS

Heater Rated Appliance .....	AFUE Certified
Heats up to .....	Up to 900 sq ft
Burn Rate Range NG .....	10,600 - 18,000 BTUs/hr
Burn Rate Range LP .....	10,400 - 17,500 BTUs/hr
Venting .....	Rear, 4" x 6-5/8" DV
Ignition System .....	Continuous pilot
Burner .....	Ceramic Burner
On-Off-Thermostat Switch .....	Included
Wall Thermostat .....	Included
Programmable Thermostat .....	Optional
Thermostatic Remote Control .....	Optional
Convection Blower .....	Optional
Screen .....	Included
LP Conversion Kit .....	Included
Mobile Home Certified .....	Yes
Actual Weight .....	185 lbs

## CLEARANCES TO COMBUSTIBLE MATERIALS

Side .....	2"
Rear .....	1½"
Corner .....	2"

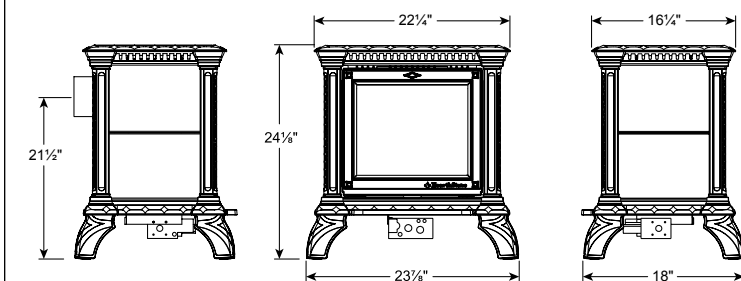

## CLASSIC STONE STYLING & WARMTH

The Tribute's DV's stone and cast iron design distributes heat quickly and evenly, while its cast iron heat exchanger maximizes heating efficiency. An adjustable flame control lets you control the amount of heat. Featuring styling that's complemented by two cast iron finishes and two stone options, the Tribute fits in any home decor.





Bari DV featured in Gray Matte with Soapstone.

## SLEEK CONTEMPORARY STYLING

The Bari DV features slim lines that compliment any style. Its cylindrical shape frames a striking flame and takes up less space than traditional rectangular stoves. Providing the radiant heat of soapstone, the Bari maximizes comfort with minimum effort.



**FINISH OPTIONS:**



Gray Matte

**STONE ACCENT:**



Polished Soapstone



Thermostatic Remote.

Bari DV featured in Gray Matte with Soapstone.



## BARI DV 8180 FEATURES AND BENEFITS

- **100lbs of soapstone** – HeatLife: long-lasting warmth
- **Space-saving footprint** – minimizes required floor space
- **Ceramic logs** – realistic flame presentation
- **High turn down** – adjust the flame to meet your desired comfort
- **Thermostatic remote** – features remote thermostat, on/off, and child lock-out
- **Continuous pilot** – maintains a warm firebox for quick starts
- **Direct-Vent technology** – combustion air is drawn from outside to reduce drafts, maintain indoor air quality, and boost efficiency

## SPECIFICATIONS

Heater Rated Appliance .....	AFUE Certified
Heats up to .....	Up to 1,300 sq ft
Burn Rate Range NG .....	16,000 - 26,500 BTUs/hr
Burn Rate Range LP .....	15,000 - 26,500 BTUs/hr
Venting .....	Top, 4" x 6-5/8" DV
Ignition System .....	Continuous pilot
Burner .....	Pan burner
On-Off-Thermostat Switch .....	Included
Thermostatic Remote Control .....	Included
Programmable Thermostat .....	Optional
LP Conversion Kit .....	Included
Mobile Home Certified .....	Yes
Actual Weight .....	300 lbs

## CLEARANCES TO COMBUSTIBLE MATERIALS

Side .....	10"
Rear .....	1"
Corner .....	7"

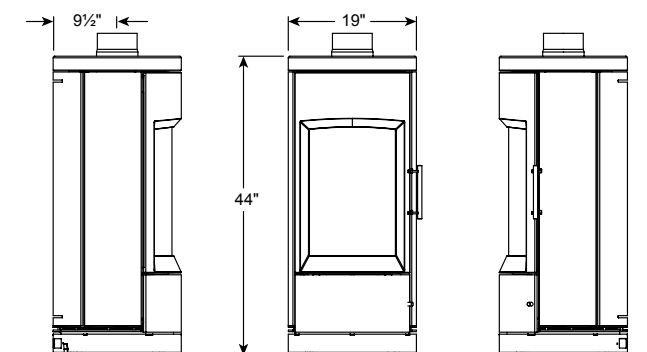





The Modena's firebox comes standard with ceramic fire stones (shown left). An optional realistic log set is available (shown right).



FINISH OPTIONS:



Charcoal



Thermostatic Remote.

Modena featured in Charcoal.

**MODENA 8140  
FEATURES AND BENEFITS**

- **Ceramic fire stones** – modern alternative to traditional logs
- **Space-saving footprint** – minimizes required floor space
- **High turn down** – adjust the flame to meet your desired comfort
- **Thermostatic remote** – features remote thermostat, on/off, and child lock-out
- **Continuous pilot** – maintains a warm firebox for quick starts
- **Direct-Vent technology** – combustion air is drawn from outside to reduce drafts, maintain indoor air quality, and boost efficiency

**SPECIFICATIONS**

Heater Rated Appliance .....	AFUE Certified
Heats up to .....	Up to 1,300 sq ft
Burn Rate Range NG .....	16,000 - 26,500 BTUs/hr
Burn Rate Range LP .....	15,000 - 26,500 BTUs/hr
Venting .....	Top, 4" x 6-5/8" DV
Ignition System .....	Continuous pilot
Burner .....	Pan burner
On-Off-Thermostat Switch .....	Included
Thermostatic Remote Control .....	Included
Programmable Thermostat .....	Optional
Ceramic Log Set .....	Optional
LP Conversion Kit .....	Included
Mobile Home Certified .....	Yes
Actual Weight .....	320 lbs

**CLEARANCES TO COMBUSTIBLE MATERIALS**

Side .....	16"
Rear .....	1"
Corner .....	11.5"

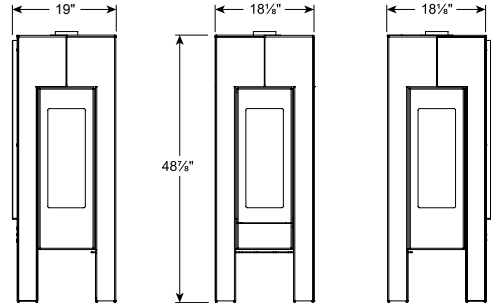

**FIRE PERFECTED FROM EVERY ANGLE**

The Modena fire glows from three sides, providing a perfect view from every angle. This stove is designed to reflect the flame with a mirrored effect. The Modena inspires with its consistency in style and clear concept.





Luno featured in Black.

## DESIGNED TO FIT A MODERN LIFESTYLE

The Luno gas stove is designed to complement modern styling. Made with two semi-circular elements, the stove remains slim while presenting a large vertical fire.



**FINISH OPTIONS:**



Gray



Black

**STONE ACCENT:**



Polished Soapstone



Thermostatic Remote.

Luno featured in Gray.

## LUNO 8160 FEATURES AND BENEFITS

- **Space-saving footprint** – minimizes required floor space
- **Ceramic logs** – realistic flame presentation
- **High turn down** – adjust the flame to meet your desired comfort
- **Thermostatic remote** – features remote thermostat, on/off, and child lock-out.
- **Continuous pilot** – maintains a warm firebox for quick starts
- **Direct-Vent technology** – combustion air is drawn from outside to reduce drafts, maintain indoor air quality, and boost efficiency

## SPECIFICATIONS

Heater Rated Appliance .....	AFUE Certified
Heats up to .....	Up to 1,300 sq ft
Burn Rate Range NG .....	16,000 - 26,500 BTUs/hr
Burn Rate Range LP .....	15,000 - 26,500 BTUs/hr
Venting .....	Top, 4" x 6-5/8" DV
Ignition System .....	Continuous pilot
Burner .....	Pan burner
On-Off-Thermostat Switch .....	Included
Thermostatic Remote Control .....	Included
Programmable Thermostat .....	Optional
LP Conversion Kit .....	Included
Mobile Home Certified .....	Yes
Actual Weight .....	250 lbs

## CLEARANCES TO COMBUSTIBLE MATERIALS

Side .....	10"
Rear .....	1"
Corner .....	7"

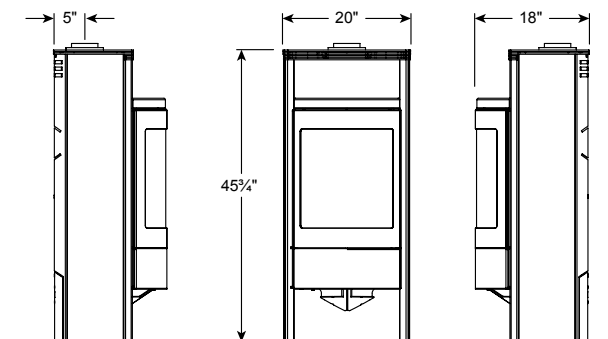



# DVI-44

## GAS INSERT



QUINLAN



Quinlan cast iron texture.



LARKIN

Larkin cast iron texture in Brown Majolica Enamel.

DVI- 44 Larkin Featured in Brown Majolica Enamel with 44" New Bronze surround, burning natural gas.



COBURN

New Bronze finish detail.

DVI- 44 Coburn featured in New Bronze with 48" surround, burning natural gas.

## UNCOMPROMISED TRANSITION OF YOUR FIREPLACE

Eliminate the cold drafts of an open fireplace and lower your utility costs by upgrading to the convenience and efficiency of the DVI-44. The stacked ledge stone refractory radiates the generous heat of the realistic flame, and the integrated convection fan ensures your comfort.

Smart remote features remote thermostat, smart thermostat, 10-level flame control, 5-speed fan control, light control, pilot control and child lock-out.





# DVI-38

## GAS INSERT



LARKIN

Larkin cast iron texture in Matte Black.



COBURN

Black finish detail.



Easy access: A sliding valve tray allows a qualified gas technician access to the gas components on the right side of the insert.



QUINLAN

Quinlan cast iron texture in Brown Majolica Enamel.

DVI-38 Quinlan featured in Brown Majolica Enamel with 44" New Bronze surround, burning natural gas.

## TRANSFORM YOUR HEARTH

The DVI-38 includes all the features necessary to transform your hearth into an energy efficient heating solution. With a realistic fire and smart remote control, you're sure to enjoy the comfort and convenience of our direct vent gas insert.

Smart remote – features remote thermostat, smart thermostat, 10-level flame control, 5-speed fan control, auxiliary outlet and child lock-out.





# DVI-44

## GAS INSERT

# DVI-38

## GAS INSERT

### DVI-44 8860

#### FEATURES AND BENEFITS

- **HeatWave refractory** – Directs the heat of the flame to the glass, maximizing the radiant heat from the stove.
- **Ceramic logs and burner** – realistic flame presentation
- **2-stage burner** – turn the rear burner on/off and modulate the flame height
- **High turn down** – adjust the flame to meet your desired comfort
- **Built-in convection blower** – circulates warm air
- **Smart remote** – features remote thermostat, smart thermostat, 10-level flame control, 5-speed fan control, light control, pilot control and child lock-out
- **Intermittent pilot** – conserves gas when unit is off
- **Heat exchange system** – maximizes heat output and improves efficiency
- **Direct-Vent technology** – combustion air is drawn from outside to reduce drafts, maintain indoor air quality, and boost efficiency

#### SPECIFICATIONS

Heater Rated Appliance.....	AFUE Certified
Heats up to.....	Up to 2,000 sq ft
Burn Rate Range NG.....	15,000 - 43,000 BTUs/hr
Burn Rate Range LP.....	17,000 - 46,000 BTUs/hr
Venting.....	3" intake, 4" exhaust
Ignition System.....	ProFlame II Intermittent pilot
Burner.....	2-Stage Ceramic Burner
On-Off-Remote Switch.....	Included
Smart Remote Control.....	Included
Convection Blower.....	Included
Screen.....	Included
Ambient Light.....	Included
LP Conversion Kit.....	Optional
Mobile Home Certified.....	Yes
Actual Weight.....	240 lbs
Minimum Fireplace Opening.....	35½" W x 26" H x 19" D

#### CLEARANCES TO COMBUSTIBLE MATERIALS

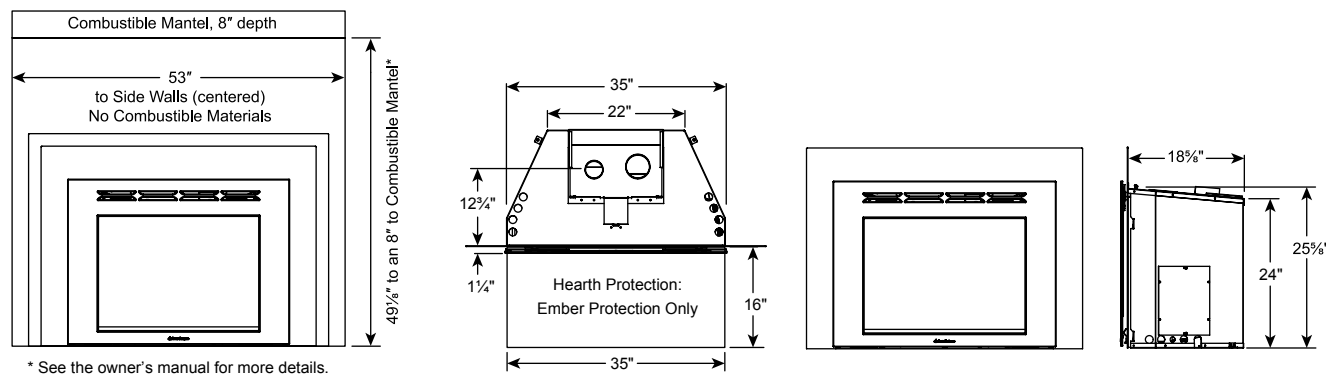

#### FACADE OPTIONS

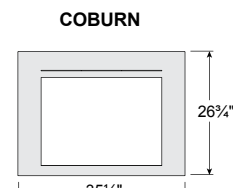
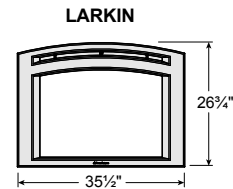
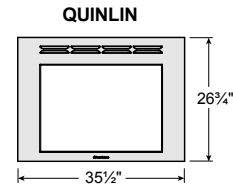

#### SURROUND OPTIONS

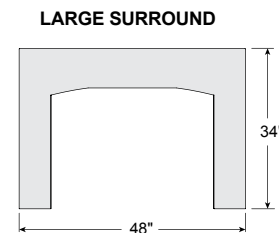
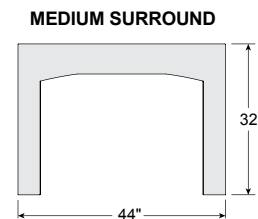

#### FINISH OPTIONS

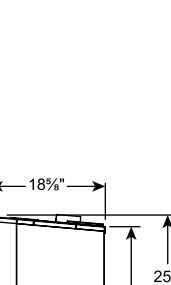
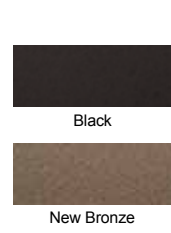
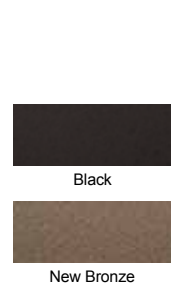
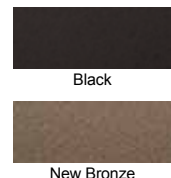
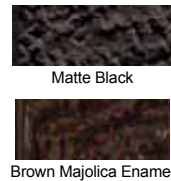

### DVI-38 8850

#### FEATURES AND BENEFITS

- **HeatWave refractory** – Directs the heat of the flame to the glass, maximizing the radiant heat from the stove.
- **Ceramic logs and burner** – realistic flame presentation
- **2-stage burner** – turn the rear burner on/off and modulate the flame height
- **High turn down** – adjust the flame to meet your desired comfort
- **Built-in convection blower** – circulates warm air
- **Smart remote** – features remote thermostat, smart thermostat, 10-level flame control, 5-speed fan control, auxiliary outlet and child lock-out
- **Intermittent pilot** – conserves gas when unit is off
- **Heat exchange system** – maximizes heat output and improves efficiency
- **Direct-Vent technology** – combustion air is drawn from outside to reduce drafts, maintain indoor air quality, and boost efficiency

#### SPECIFICATIONS

Heater Rated Appliance.....	AFUE Certified
Heats up to.....	Up to 1,700 sq ft
Burn Rate Range NG.....	17,000 - 38,000 BTUs/hr
Burn Rate Range LP.....	16,000 - 38,000 BTUs/hr
Venting.....	3" intake, 3" exhaust
Ignition System.....	ProFlame Intermittent pilot
Burner.....	2-Stage Ceramic Burner
On-Off-Remote Switch.....	Included
Smart Remote Control.....	Included
Convection Blower.....	Included
Screen.....	Included
Ambient Light.....	Included
LP Conversion Kit.....	Optional
Mobile Home Certified.....	Yes
Actual Weight.....	200 lbs
Minimum Fireplace Opening.....	33½" W x 22½" H x 16½" D

#### CLEARANCES TO COMBUSTIBLE MATERIALS

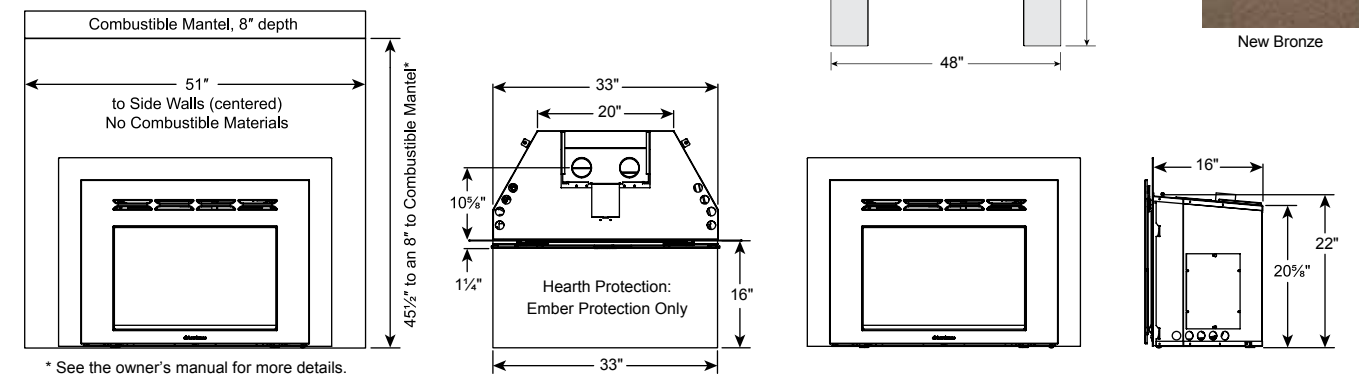

#### FACADE OPTIONS

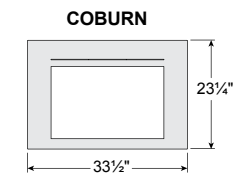
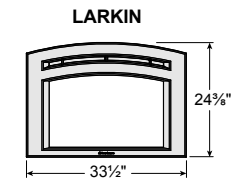
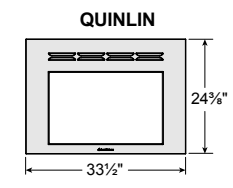

#### SURROUND OPTIONS

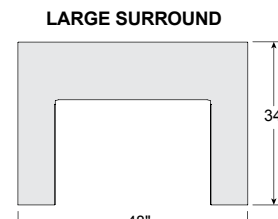
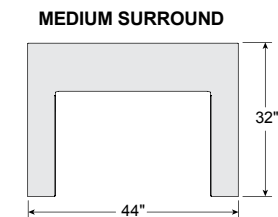
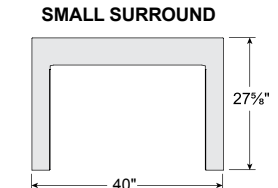

#### FINISH OPTIONS

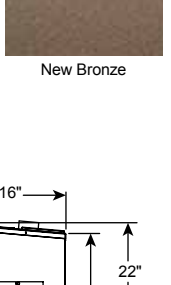
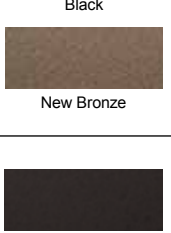
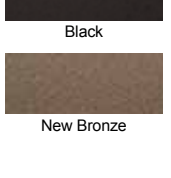
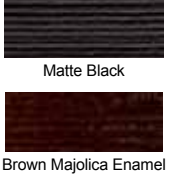



# DVI-HT KILLINGTON

## GAS INSERT



### FINISH OPTIONS:



Matte Black

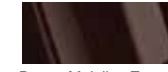

Brown Majolica Enamel

### DVI HT 8890 FEATURES AND BENEFITS

- **Ceramic logs and burner** – realistic flame presentation
- **High turn down** – adjust the flame to meet your desired comfort
- **Built-in convection blower** – circulates warm air
- **Wall thermostat** – easy operation
- **Continuous pilot** – maintains a warm firebox for quick starts
- **Cast iron heat exchanger** – maximizes heat output and improves efficiency
- **Direct-Vent technology** – combustion air is drawn from outside to reduce drafts, maintain indoor air quality, and boost efficiency

### SPECIFICATIONS

Heater Rated Appliance.....	AFUE Certified
Heats up to.....	Up to 1,500 sq ft
Burn Rate Range NG.....	13,000 - 33,000 BTUs/hr.
Burn Rate Range LP.....	12,000 - 33,000 BTUs/hr.
Venting.....	3" intake, 3" exhaust
Ignition System.....	Continuous pilot
Burner.....	2-Stage Ceramic Burner
On-Off-Thermostat Switch.....	Included
Wall Thermostat.....	Included
Programmable Thermostat.....	Optional
Thermostatic Remote Control.....	Optional
Convection Blower.....	Included
Screen.....	Included
LP Conversion Kit.....	Included
Mobile Home Certified.....	Yes
Actual Weight.....	185 lbs
Small Surround.....	38" x 27½"
Large Surround.....	44" W x 31¼" H
Minimum Fireplace Opening.....	28½" W x 20" H x 16½" D



DVI-HT Killington featured in Brown Majolica Enamel.

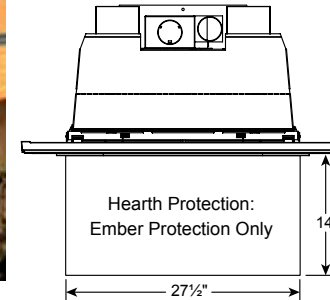

### CLEARANCES TO COMBUSTIBLE MATERIALS

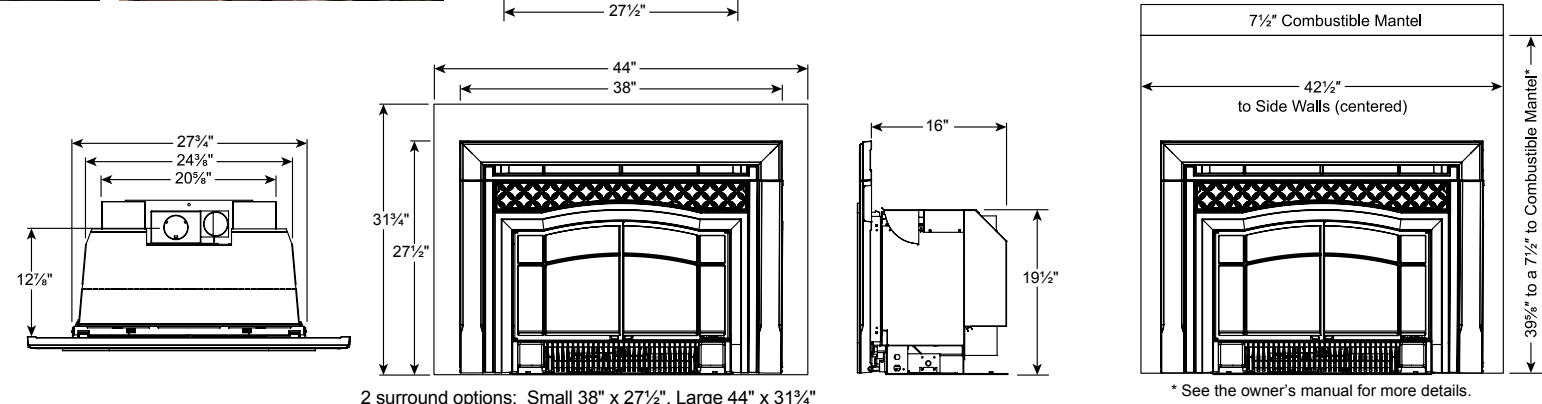

2 surround options: Small 38" x 27½", Large 44" x 31¼"

\* See the owner's manual for more details.

## AN INSTANT STYLE UPGRADE TO YOUR FIREPLACE

Gas-fired and designed to fit perfectly into your fireplace, the Killington features a double heat exchanger that allows less heat up the chimney, more into your house. Adjust the flame height upwards, and the Killington will keep you warm and comfortable. Adjust it down – and enjoy a gentle warmth along with a beautiful flame.



# DVI-HT WILLOUGHBY & MAIDSTONE

## GAS INSERT



DVI-HT Maidstone featured in Brown Majolica Enamel, small surround with Autumn Brown Granite.



### FINISH OPTIONS:

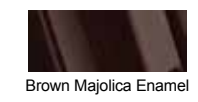

### STONE OPTIONS:



DVI-HT Maidstone featured in Matte Black, small surround with matching cast iron panels.



DVI-HT Willoughby featured in Matte Black, small surround with Polished Soapstone.

## DVI HT 8890 FEATURES AND BENEFITS

- **Stone selection** – customize your stove for any decor
- **Ceramic logs and burner** – realistic flame presentation
- **High turn down** – adjust the flame to meet your desired comfort
- **Built-in convection blower** – circulates warm air
- **Wall thermostat** – easy operation
- **Continuous pilot** – maintains a warm firebox for quick starts
- **Cast iron heat exchanger** – maximizes heat output and improves efficiency
- **Direct-Vent technology** – combustion air is drawn from outside to reduce drafts, maintain indoor air quality, and boost efficiency

## SPECIFICATIONS

Heater Rated Appliance .....	AFUE Certified
Heats up to .....	Up to 1,500 sq ft
Burn Rate Range NG .....	13,000 - 33,000 BTUs/hr.
Burn Rate Range LP .....	12,000 - 33,000 BTUs/hr.
Venting .....	3" intake, 3" exhaust
Ignition System .....	Continuous pilot
Burner .....	2-Stage Ceramic Burner
On-Off-Thermostat Switch .....	Included
Wall Thermostat .....	Included
Programmable Thermostat .....	Optional
Thermostatic Remote Control .....	Optional
Convection Blower .....	Included
Screen .....	Included
LP Conversion Kit .....	Included
Mobile Home Certified .....	Yes
Actual Weight .....	185 lbs
Small Surround .....	42 $\frac{1}{2}$ " x 26 $\frac{1}{8}$ "
Large Surround .....	49 $\frac{1}{4}$ " W x 32 $\frac{3}{8}$ " H
Minimum Fireplace Opening .....	28 $\frac{1}{2}$ " W x 20" H x 16 $\frac{1}{2}$ " D

## CLEARANCES TO COMBUSTIBLE MATERIALS

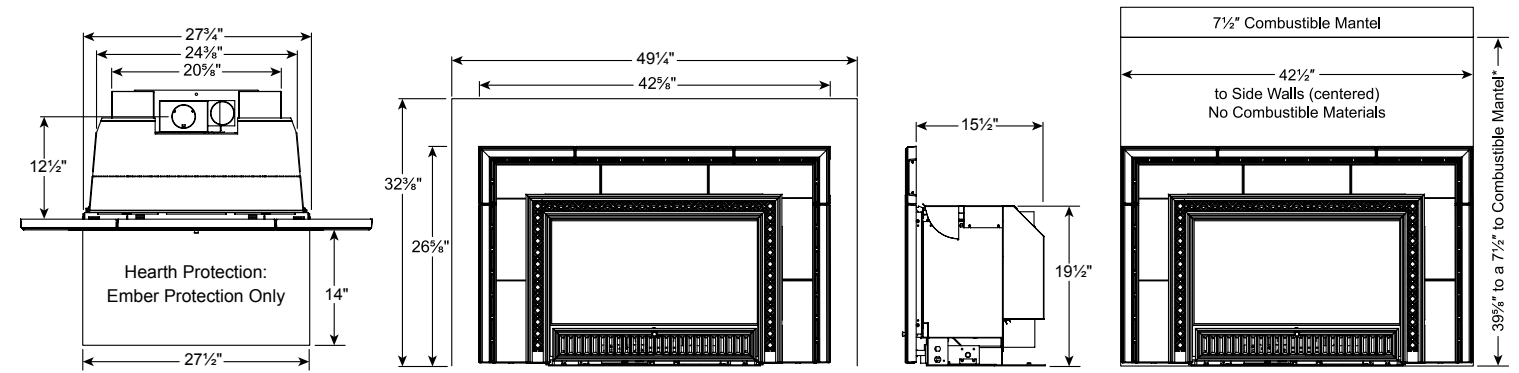

## UPDATE A ROOM WITH EFFICIENCY AND CHARM

The Maidstone Direct-Vent gas insert turns your fireplace into an efficient heat source. Gas-fired and designed to fit perfectly into your fireplace, the Maidstone features a double heat exchanger that reduces the heat lost up the chimney, so more heat is distributed into your home. With a variable flame, you regulate heat output as you desire.



	BRISTOL DX	STERLING HT	CHAMPLAIN	TUCSON DX
<b>SPECIFICATIONS</b>				
Venting	Top, 4" x 6 <sup>5</sup> / <sub>8</sub> "	Top, 4" x 6 <sup>5</sup> / <sub>8</sub> " Rear, 4"x6 <sup>5</sup> / <sub>8</sub> " or 5"x8"	45°, 4" x 6 <sup>5</sup> / <sub>8</sub> "	45°, 4" x 6 <sup>5</sup> / <sub>8</sub> "
Venting: Minimum Vertical Rise	36"	0"	24"	9"
Ignition System	ProFlame II intermittent pilot	Continuous pilot	Continuous pilot	ProFlame intermittent pilot
Burner	2-stage ceramic	Ceramic	Stainless steel pan	Ceramic
On-Off Switch	On-Off-Remote	On-Off-Thermostat	On-Off-Thermostat	On-Off-Remote
Remote Control	Included	Optional	Optional	Included
Wall Thermostat	N/A	Included	Included	N/A
Programmable Thermostat	N/A	Optional	Optional	N/A
Convection Blower	Included	Optional	Optional	Included
Screen	Included	Included	Included	Included
LP Conversion Kit *	Optional	Included	Included	Optional
Mobile-home certified	Yes	Yes	Yes	Yes
Actual weight (lbs)	180	230	220	155
Shipping weight (lbs) <b>(1)</b>	205	260	260	200
<b>PERFORMANCE</b>				
Heating capacity up to <b>(4)</b>	1,800 sq. ft.	1,800 sq. ft.	1,800 sq. ft.	1,200 sq. ft.
Burn Rate Range NG (BTUs/hr)	16,000 to 36,000	12,000 to 38,000	21,500 to 35,000	18,000 to 26,000
Burn Rate Range LP (BTUs/hr)	10,000 to 33,000	12,000 to 38,000	21,500 to 35,000	21,600 to 25,000
Certified steady state efficiency <b>(3)</b>	79% NG 74% LP	81%NG** 86%LP***	77% NG 72% LP	70% NG 77% LP
AFUE <b>(3)</b>	79.4% NG 72.8% LP	70%NG** 72.8%LP**	68.5% NG 65.5% LP	64.6% NG 68.0% LP
P4 EnerGuide efficiency <b>(3)</b>	80.0% NG / LP	74.0% NG / LP	63.1% NG / LP	61.0% NG / LP
<b>CLEARANCES (5)</b>				
Minimum clearance to combustibles				
Side	16"	4"	4"	6"
Rear	2"	2"	2"	2"
Corner	11"	2"	2"	4"

Note: Always refer to the Hearthstone Owner's Manual and the local authority having jurisdiction in your area for the specific installation requirements for your stove.

\* All products ship ready to burn natural gas.

\*\* Efficiency values with 5" x 8" venting

\*\*\* Efficiency values with 4" x 6<sup>5</sup>/<sub>8</sub>" venting

	STOWE DX	TRIBUTE DV	BARI DV	MODENA	LUNO
<b>SPECIFICATIONS</b>					
Venting	45°, 4" x 6 <sup>5</sup> / <sub>8</sub> "	Rear, 4" x 6 <sup>5</sup> / <sub>8</sub> "	Top, 4" x 6 <sup>5</sup> / <sub>8</sub> "	Top, 4" x 6 <sup>5</sup> / <sub>8</sub> "	Top, 4" x 6 <sup>5</sup> / <sub>8</sub> "
Venting: Minimum Vertical Rise	9"	0"	24"	24"	24"
Ignition System	ProFlame intermittent pilot	Continuous pilot	Continuous pilot	Continuous pilot	Continuous pilot
Burner	Ceramic	Ceramic	Stainless steel pan	Stainless steel pan	Stainless steel pan
On-Off Switch	On-Off-Remote	On-Off-Thermostat	On-Off-Thermostat	On-Off-Thermostat	On-Off-Thermostat
Remote Control	Included	Optional	Included	Included	Included
Wall Thermostat	N/A	Included	Optional	Optional	Optional
Programmable Thermostat	N/A	Optional	Optional	Optional	Optional
Convection Blower	Included	Optional	N/A	N/A	N/A
Screen	Included	Included	N/A	N/A	N/A
LP Conversion Kit *	Optional	Included	Included	Included	Included
Mobile-home certified	Yes	Yes	Yes	Yes	Yes
Actual weight (lbs)	155	185	300	320	250
Shipping weight (lbs) <b>(1)</b>	200	210	340	360	290
<b>PERFORMANCE</b>					
Heating capacity up to <b>(4)</b>	1,200 sq. ft.	900 sq. ft.	1,300 sq. ft.	1,300 sq. ft.	1,300 sq. ft.
Burn Rate Range NG (BTUs/hr)	18,000 to 26,000	10,600 to 18,000	16,000 to 26,500	16,000 to 26,500	16,000 to 26,500
Burn Rate Range LP (BTUs/hr)	21,600 to 25,000	10,400 to 17,500	15,000 to 26,500	15,000 to 26,500	15,000 to 26,500
Certified steady state efficiency <b>(3)</b>	70% NG 77% LP	77% NG 76% LP	74% NG 76% LP	73% NG 78% LP	77% NG 77% LP
AFUE <b>(3)</b>	64.6% NG 68.0% LP	73.9% NG 73.1% LP	64.5% NG 66.8% LP	64.6% NG 70.4% LP	76.2% NG 67.4% LP
P4 EnerGuide efficiency <b>(3)</b>	61.0% NG / LP	63.3% NG 66.3% LP	55.8% NG / LP	55.8% NG / LP	64.3% NG / LP
<b>CLEARANCES (5)</b>					
Minimum clearance to combustibles					
Side	6"	2"	10"	16"	10"
Rear	2"	1 <sup>1</sup> / <sub>2</sub> "	1"	1"	1"
Corner	4"	2"	7"	11 <sup>1</sup> / <sub>2</sub> "	7"



	DVI-44 QUINLIN   LARKIN   COBURN	DVI-38 QUINLIN   LARKIN   COBURN
<b>SPECIFICATIONS</b>		
Venting	3" intake, 4" exhaust	3" intake, 3" exhaust
Ignition System	ProFlame II intermittent pilot	ProFlame intermittent pilot
Burner	2-stage ceramic	2-stage ceramic
On-Off Switch	On-Off-Remote	On-Off-Remote
Remote Control	Included	Included
Wall Thermostat	N/A	N/A
Programmable Thermostat	N/A	N/A
Convection Blower	Included	Included
Screen	Included	Included
Ambient Light	Included	Included
LP Conversion Kit *	Optional	Optional
Mobile-home certified	Yes	Yes
Actual weight (lbs)	240	200
Shipping weight (lbs) <b>(1)</b>	280	240
<b>PERFORMANCE</b>		
Heating capacity up to <b>(4)</b>	2,000 sq. ft.	1,700 sq. ft.
Burn Rate Range NG (BTUs/hr)	15,000 to 43,000	17,000 to 38,000
Burn Rate Range LP (BTUs/hr)	17,000 to 46,000	16,000 to 38,000
Certified steady state efficiency <b>(3)</b>	73% NG 76% LP	73% NG 74% LP
AFUE <b>(3)</b>	66.2% NG 68.5% LP	66.9% NG 65.3% LP
P4 EnerGuide efficiency <b>(3)</b>	69.6% NG / LP	71.2% NG / LP
<b>CLEARANCES <b>(5)</b></b>		
Minimum Mantel Height (8" mantel depth)	49½"	45½"
Ember Protection (centered in front of insert)	35" W x 16" D	33" W x 16" D
Minimum Fireplace Opening	35½" W x 26" H x 19" D	33½" W x 22½" H x 16½" D
Minimum to Side Walls (centered on insert)	53"	51"

Note: Always refer to the Hearthstone Owner's Manual and the local authority having jurisdiction in your area for the specific installation requirements for your stove.

DVI-HT MAIDSTONE   WILLOUGHBY   KILLINGTON
3" intake, 3" exhaust
Continuous pilot
2-stage ceramic
On-Off-Thermostat
Optional
Included
Optional
Included
Included
N/A
Included
Yes
185
215
1,500 sq. ft.
13,000 to 33,000
12,000 to 33,000
82% NG 80% LP
74.5% NG 71.1% LP
67.1% NG / LP
39⅝"
27½" W x 14" D
28½" W x 20" H x 16½" D
42½"

- (1)** Shipping weight includes facade and small surround.
- (2)** EnerGuide is a Government of Canada rating system that provides consumers with comparative information on the energy performance of energy-using products sold in Canada. For more information on the EnerGuide Program, please go to the EnerGuide Web site at: <http://oee.nrcan.gc.ca/energyguide/index.cfm>
- (3)** Steady state efficiencies vary dependent upon installation, venting configuration, altitude, gas values, and other installation variables.
- (4)** Heating capacity is an approximation dependent upon floor plan, ceiling height, house construction, venting configuration, heat loss, and geographic location of home.
- (5)** All measurements are taken from the closest surface of the unit. Clearances in this catalog are for reference only. Refer to Owner's Manual for exact specifications prior to installation.

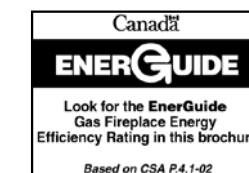

EnerGuide is a Government of Canada rating system that provides consumers with comparative information on the energy performance of energy-using products sold in Canada. For more information on the EnerGuide Program, please go to the EnerGuide web site at: <http://oee.nrcan.gc.ca/energyguide/index.cfm>

Hearthstone Quality Home Heating Products, Inc., warrants all its gas products to the original purchaser for the lifetime of the appliance to be free from defects in material and workmanship, with certain limitations as defined in our Limited Lifetime Warranty policy. See your Hearthstone dealer for complete details and a copy of our warranty policy.

Hearthstone Sterling is a registered trademark of Hearthstone Quality Home Heating Products, Inc.





[www.hearthstonestoves.com](http://www.hearthstonestoves.com)  
802.888.5235



Hearthstone Quality Home Heating Products  
317 Stafford Avenue  
Morrisville Vermont 05661 USA

