



Northwest Stoves Ltd.

5505 268th Street
Langley, B.C.
V4W 3W1

Phone: (604)857-8816
Toll Free: 1-800-663-0462
Fax: (604)857-8963
Toll Free Fax: 1-800-667-6162

Astronomers have determined the age of the universe to be 13.7 billion years old. Reid agrees. He was there.



Email: nws@northweststoves.ca

Visit us on the web
at
[northweststoves.ca!](http://northweststoves.ca)



Contact Us



Todd Ayley (ext. 26)
tayley@northweststoves.ca

Connee Ceresney (ext. 23)
cceresney@northweststoves.ca

Dawne Gleadhill (ext. 29)
dgleadhill@northweststoves.ca

Mike Harstone (ext. 30)
mharstone@northweststoves.ca

Reid Harvey (ext. 55)
rharvey@northweststoves.ca

Dan Kosovic (ext. 27)
dkosovic@northweststoves.ca

Mike Long (ext. 21)
mlong@northweststoves.ca

Martin Mabbs(c-403-872-1113)
hojanen@northweststoves.ca

David Rosvold (ext. 31)
drosvold@northweststoves.ca

Wayne Rourke (ext. 32)
wrourke@northweststoves.ca

Greg Stalman (ext. 36)
gstalman@northweststoves.ca

Clinton Tod (ext. 22)
ctod@northweststoves.ca

Chris Vecchies (ext. 42)
cvecchies@northweststoves.ca

Northwest Stoves welcomes Michael Long

New to the shipping department this fall, is Mike Long. Mike had the unfortunate timing to join the Northwest Stoves team right in the middle of October, which, of course, meant that he had to hit the ground running on his first day.

But he was more than up to the task with his casual smile, eagerness and good sense of humour (which is a good thing—otherwise we may have been forced to kill him). 

Mike has come to us after working for Zellers in the receiving department for a few years. He has been able to come in seamlessly and pick up the Northwest ways very quickly, although I'm sure the busy season pace caught him a little off guard.



Becoming festive, Mike stands tall in the Northwest Stoves warehouse

But Mike was fortunate this year, as he was able to travel to Mexico for a family wedding in November—something all of us would love to be able to do.

Mike also has an athletic background, as he was selected team MVP when he played wide receiver for his Abbotsford High School a few years back.

Unfortunately, when one person joins Northwest Stoves, often someone had to leave, which is the case with **Hannu (Hank) Ojanen**, who left us in September. After three years of providing accurate, quality shipping, family issues compelled his sad departure. We wish Hank and Evy well and know that his family will be well taken care of as long as Hank has anything to say on the subject. 

Northwest Stoves Holiday Hours

Up to Dec. 23rd
Open regular hours

Dec. 24th
Open until 1:00PM

Dec. 25th & 26th
Closed

Dec. 29th & 30th
Open regular hours

Dec. 31st
Open until 1:00PM

January 1st & 2nd
Closed



Serving the Fireplace Industry For More Than Twenty-Five Years

Volume 8, Issue 3
December 2008

NORTHWEST STOVES LTD.

30
YEARS

HotTimes

A NEWSLETTER ON WHAT'S HOT AND WHAT'S NOT

Scan DSA4 and the Kojo/Jotul GF370

New Partnership

Scan announces a new deal with Green Mountain Soapstone. You can now turn your DSA4 into an elegant free standing soapstone heater.

Introducing the Kojo, a soapstone "vessel" built specifically by Green Mountain Soapstone to handle the DSA4 wood burning insert.

The many virtues of soapstone now make the unit with the lowest recorded emissions for a non-catalytic insert an even more impressive fireplace.



The carcass will continue to heat long after the fire in the insert goes out. The DSA4's industry leading efficiency and patented air wash system have been getting heads to turn frequently in recent months. Along with the Kojo, we expect many more sore necks from heads spinning.

People who have been exposed to the Kojo know what an awe inspiring thing of beauty it is and have been asking for it. We will have pricing available in the coming weeks for the Kojo. You can expect them to arrive at Northwest Stoves in February.

Revolutionary Stove

Coming soon from Jotul is the award winning GF370 freestanding stove. With its modern design and elegant three-sided fire view, the GF370 creates an exceptional view of the fire from any angle. The GF370 of-



fers the same contemporary cast iron styling as the Vesta Award Winning F370 wood stove, but in a freestanding direct vent stove. Some of the standard features include Electronic Ignition, Accent Lighting and a variable speed blower.

Production on this stove is set to begin. See your rep for details.

Inside this issue:

Scan Kojo & Jotul GF370	1
Greyhound Courier Express	1
Hearth Classics Load-Spreading Disks	2
Marquis Clean View Kits	2
Economy Hits Us all Hard	3
Thank you & Upcoming Dates	3
Welcome Mike Long	4
Northwest Stoves Holiday Hours	4



Greyhound guarantees the next bus—or it's free!!!

Greyhound can help
This holiday season, if you wish to have your courier shipment arrive when you need it, Northwest Stoves and Greyhound Courier Express can help make it happen. For an extra charge of \$15, Greyhound will ensure



your shipment will go out on **the first available bus**, or else your shipment is free!
Greyhound Courier is the preferred prepaid choice used by Northwest Stoves and offers timely service to many points

throughout BC, Alberta and beyond. Call for a rate quote that is **exempt** from cubing. Greyhound does two daily pick ups at Northwest Stoves. The first is a 10:00 AM pick for items to be delivered same day within the lower mainland. The second is at 2:30 for out of town shipments.

"Obstacles are those frightful things you see when you take your eyes off your goal"

- Henry Ford



Hearth Classics Load-Spreading Discs

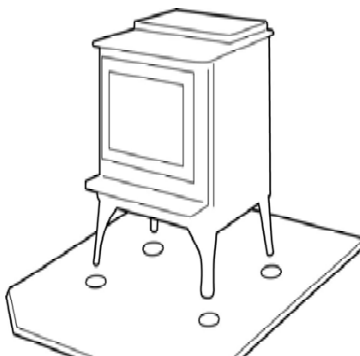

Example of Hearth Classics Load-Spreading Discs



"Works well while under constant supervision and cornered like a rat in a trap."

- Wayne during a recent employee evaluation



Clint returns to BC Place in October to find someone "helped" tear down our booth a bit early

Cracked Hearth Pad?

Cracks can occur months after the pad has been installed. Hearth Classics explains why and how to prevent it.

Reason #1: Some models of wood stoves have legs that do not offer adequate support for their massive weights. In addition, stoves with leveler bolts concentrate the weight of the stove onto 4 small points, exerting too much pressure for the tile to withstand.

Reason #2: Inadequate protection of the tile during installation of a heavy stove. When installing any stove, it is relatively easy for a stove leg to score the tile as the stove is pushed across the hearth pad. Or if the

stove is dropped, even from as little as 1/2", the resulting impact creates about 10 times the pressure. This can cause stress fractures in the tile. The installer may not even notice that the scoring occurred because the stress and cracking in the tile may not be visible.

If a tile (or tiles) is scored, over time, as the stove is repeatedly heated and cooled, the stresses along the score result in the tile cracking.

The Solution.

Hearth Classics now offers a set of 4 inexpensive Load-Spreading disks that can prevent the problem. A disk is placed under each of the stove's feet. The Load-Spreading disks are a proactive way

to avoid customer warranty claims.

When installing any stove, especially a heavy stove with sharp feet, it is essential to protect the tile when moving the stove onto the hearth pad. Do this by sliding the stove into position on a piece of carpet or some other material that supports the stove legs. Then remove the protective material. Always support the weight of the stove while lowering it into place. Do not allow it to be dropped even from a distance of 1 cm.

To get a set of 4 Load-Spreading Discs, use the code DY-KINSDI01. The list price is just \$2.89 so get some now!

HB36CVCK vs. Z36CVCK

Clean View Differences

We often have dealers ordering the wrong clean view kit when ordering a Marquis fireplace. Here is the differences between the two to make it easier for you.

While both have virtually the same dimensions, there are subtle differences. For example, the Z36CVCK comes with optional 8" standoffs to allow for the greater clearance requirements of the MQZDV3320 fireplace. The HB version only has the 6" high size. The HB36CVCK has a

higher framing area (25 3/16" versus 23 5/16" for the Z36CVCK).

While these differences are minimal, they could potentially be important, depending on the installation requirements you have.

Always remember to allow for the extra framing dimensions required when planning an install for the Marquis Fireplace which has a clean view kit included. It may seem obvious, but it's surely not a mistake that's easy to correct later.

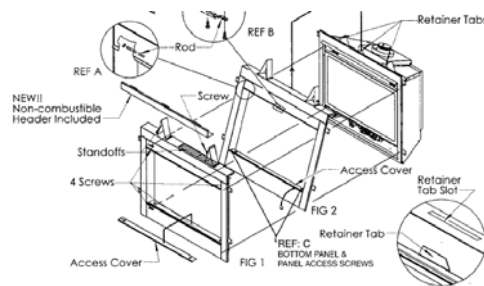

Thank you!!!

It's been another bizarre year in the industry and we want to take this time to thank everyone for making it a successful one at Northwest Stoves.

Happy Holidays to all of our dealers and manufacturers and the best of luck in what promises to be a tumultuous 2009!!!



Upcoming Industry Dates

Jotul Meeting
Jan. 13-17

Hearthstone Meeting
Jan. 28-31

BC Home & Garden Show
Feb. 18-22

HPBA Meeting in Reno, NV
March 17-21

Economy Creates Interesting Times

According to a recent report, the abyss appears to be even deeper than many people originally thought.

In the executive suites of Wall Street and Washington, they are beginning to sound the alarm bells regarding a new wave of mortgages with strange names that are becoming all too familiar. If you thought sub-primes were insanely reckless, wait until you hear what's coming.

We likely won't face the same problems in Canada—at least not to the same extent—but it's still scary.

Northwest Stoves is in a good position to weather the economic storm. We will continue to maintain our inventory levels up to their usual seasonal highs. You will be able to go ahead and plan that install with confidence in most cases as we will do our best to make sure we have what you need.

People in the higher



income brackets will likely still continue with any renovations they may have been planning, despite losing money in investments. One of the benefits of a recession is that big ticket items—such as the home renovation they have been putting off—become affordable. It also helps put some money back into their home long term.

A recession means lower interest rates, making money easier to borrow. Housing starts are way down, meaning construct

ion workers are out of work and offering competitive rates. It also means that retailers and suppliers are feeling the pinch and may be ready to offer deals on materials.

Woodstoves and gas space heaters are a necessity to some people. Just ask the thousands of people with no power in sub-freezing temperatures throughout New England as I write this.

As a result, Northwest Stoves is committed to providing the material you require in the timely shipping you expect from us. We aim to provide straight forward service and will have our ears open to advice as well. We want to help.

In these very interesting times, we hope to be able to work together with each of you and ensure we can get through any bumps in the road as painlessly as possible.

